

University of Rajshahi

Rajshahi-6205

Bangladesh.

RUCL Institutional Repository

<http://rulrepository.ru.ac.bd>

Department of Botany

PhD Thesis

2013

Genetic Diversity and Combining Ability in Maize (*Zea mays* L.)

Haydar, F. M. Ali

University of Rajshahi

<http://rulrepository.ru.ac.bd/handle/123456789/679>

Copyright to the University of Rajshahi. All rights reserved. Downloaded from RUCL Institutional Repository.

GENETIC DIVERSITY AND COMBINING ABILITY IN MAIZE (*Zea mays* L.)



Ph.D. Thesis

By
F. M. Ali Haydar
M.Sc, M.Phil.

JULY 2013

**BIOMETRICAL GENETICS LAB.
DEPARTMENT OF BOTANY
FACULTY OF LIFE AND EARTH SCIENCE
UNIVERSITY OF RAJSHAHI
RAJSHAHI-6205, BANGLADESH**

GENETIC DIVERSITY AND COMBINING ABILITY IN MAIZE (*Zea mays* L.)



*A thesis submitted for the degree
of
Doctor of Philosophy
in the
Department of Botany
University of Rajshahi, Bangladesh*

BY
F. M. Ali Haydar
M.Sc, M.Phil.

JULY 2013

**BIOMETRICAL GENETICS LAB.
DEPARTMENT OF BOTANY
FACULTY OF LIFE AND EARTH SCIENCE
UNIVERSITY OF RAJSHAHI
RAJSHAHI-6205, BANGLADESH**



**Ph.D.
Thesis**

GENETIC DIVERSITY AND COMBINING ABILITY IN MAIZE (*Zea mays* L.)



A Thesis

**Submitted to the University of Rajshahi
for the degree of
Doctor of philosophy**

**in
Botany**

BY

**F. M. Ali Haydar
M.Sc, M.Phil.**

**BIOMETRICAL GENETICS LAB.
DEPARTMENT OF BOTANY
FACULTY OF LIFE AND EARTH SCIENCE
UNIVERSITY OF RAJSHAH
RAJSHAH-6205, BANGLADESH**

**GENETIC DIVERSITY AND COMBINING
ABILITY IN MAIZE (*Zea mays* L.)**

F.M. Ali Haydar

2013

GENETIC DIVERSITY AND COMBINING ABILITY IN MAIZE (*Zea mays* L.)



A Thesis

**Submitted to the University of Rajshahi
for the degree of
Doctor of philosophy**

**in
Botany**

BY

**F. M. Ali Haydar
M.Sc, M.Phil.**

Under the guidance of

DR. NISHIT KUMAR PAUL M.Sc., Ph. D.,
Professor

**BIOMETRICAL GENETICS LAB.
DEPARTMENT OF BOTANY
FACULTY OF LIFE AND EARTH SCIENCE
UNIVERSITY OF RAJSHAH
RAJSHAH-6205, BANGLADESH**



**Ph.D.
Thesis**

**GENETIC DIVERSITY AND COMBINING
ABILITY IN MAIZE (*Zea mays* L.)**

F.M. Ali Haydar

2013

Professor Nishit Kumar Paul
B.Sc. (Hons.), M.Sc.
Ph. D (Wales)



Department of Botany
University of Rajshahi
Rajshahi-6205,
Bangladesh

CERTIFICATE

I hereby certify that the research work, entitled “GENETIC DIVERSITY AND COMBINING ABILITY IN MAIZE (Zea mays L.)” submitted for the degree of Doctor of Philosophy in the subject of Botany is a bonafide research work carried out by F.M. Ali Haydar under my supervision in the University of Rajshahi, Rajshahi-6205, Bangladesh. The results of investigation, which embodied here are original and have not been submitted before in substance for any other degree of this or any other university.

(Dr. Nishit Kumar Paul)
Professor and Supervisor
Department of Botany,
University of Rajshahi,
Bangladesh.



*DEDICATED
TO
LATE PROFESSOR M. A. KHALEQUE
AND
MY DEPARTED PARENTS*



DECLARATION

I hereby declare that the whole research work submitted as a thesis which is the result of my own original investigation for the fulfillment of the degree of Doctor of Philosophy in Botany, Faculty of Life and Earth Science at the University of Rajshahi, Bangladesh.

.....
(F. M. Ali Haydar)
Candidate

ACKNOWLEDGEMENTS

At first, In the name of **ALLAH**, who is the source of entire knowledge and wisdom endowed to mankind and His Holy Prophet **MUHAMMAD** (Peace Be upon Him), who is forever a torch of guidance and knowledge for humanity as a whole.

This work was initiated under the able supervision of the late Dr. M. A. Khaleque, Professor, Department of Botany, University of Rajshahi. I remember with gratitudes his scholastic guidance, supervision, suggestion, advice, constant inspiration, encouragement and sympathetic co-operation during research work. I pray eternal peace for his departed soul.

After the sudden demise of Prof. M. A. Khaleque, Prof. Nishit Kumar Paul, Department of Botany, University of Rajshahi supervised my research work. I am grateful to Prof. Paul for his scholastic guidance, supervision, suggestion, advice for preparing the manuscript.

I wish to express my sincere appreciation to Professor Dr A. K. M. Rafiul Islam, Chairman of the Department of Botany, University of Rajshahi for his moral support and cooperation in completion of my thesis.

I am also grateful to my respected teacher Professor Dr. M. Firoz Alam for his helpful cooperation during the course of this work.

Cordial thanks are due to Dr. M. Monzur Hossain, Professor of the Department of Botany, University of Rajshahi for his suggestions, cooperation and helpful attitude.

I am deeply indebted to Professor Dr. M. Iqbal Zuberi, Prof. Shamsun Nahar, Prof. Padma Bati Kundu, Prof. M. Nurul Amin, Prof. M. Golam Kabir, Prof. Nasima Hossain, Prof. M. Kashed Ali Sarkar, Prof. Shahidul Alam, Prof. Sabrina Naz, Prof. S.A. Haider, Prof. M. Zahangir Alam, Prof. M. Anisuzzaman, Prof. F. Begum, Dr. Gour Pada Ghosh, Dr. L. Ghosh, Dr. Farzana Asrafi Nila, Dr. A.H.M. M. Rahman, Dr. M. A. K. Azad, Dr. F. Mohol, Dr. S. N. Sima, Dr. Rubaiat Sarmin, Dr. Ahmed Imtiaz, Dr. Ahsanur Rahman, M. Parvez, Dr. Ahmed Humayan Kabir, Dr. Hasanur Rahman, R.

Karim, S. K. Nitu, U. K. Roy, M. N. Uddin, R. Rani, M. M. Rahman, Umme Qulsum, M.M.R. Sarkar and Omar Faruk of the Department of Botany, University of Rajshahi for their help and encouragement. Besides, I must express my sincere thanks to the rest of the teachers of the above department, who helped in many ways in their capacity.

I would like to express my sincere thanks to all the Research Fellows of all the research laboratories, of Botany for their continuous cooperation in completing the experiments in the field.

I am thankful to my friends and all well wishers who directly and indirectly assisted and encouraged me during the whole period of my study.

Sincere thanks are due to the research students of Biometrical Genetics Lab., Department of Botany, University of Rajshahi, namely, A. K. Azad, M. A. Samad, and Nibadita Sarker, Anuradha Roy Chowdhury for their heartfelt co-operation in different times during the whole period of my study.

My greatest debt, however, is firstly to my late parents for their blessings and then to all relatives who have made a lot of sacrifice in many ways for the cause of my study and inspired me all the time.

I am also very much thankful to Mr. Ashraful Alam, Scientific Officer, PARS, Ishurdi, Pabna who helped me in the analysis of D^2 - statistics.

I appreciate to all my friends, colleagues and Ph. D. Fellows who provided me precious suggestions and moral support during the completion of the present studies.

Finally, I am thankful to my wife and my kids who blessed me during finalizing this dissertation.

The author

CONTENTS

	Page No.
ACKNOWLEDGEMENTS	i-ii
LIST OF TABLES	viii
LIST OF FIGURES	xii
LIST OF GRAPHS	xii
LIST OF PLATES	xiii
ABSTRACT	xiv-xv
ACRONYMS	xvi
CHAPTER 1	1-9
INTRODUCTION	
CHAPTER 2	10-40
REVIEW OF LITERATURE	
CHAPTER 3	41-71
MATERIALS AND METHODS	
EXPERIMENT I	41
3.1.1 MATERIALS	
3.1.2 METHODS	41
Preparation of the Experimental Field	41
Soil and Climatic Condition of the Experimental Field	42
Experimental Layout and Size of the Experimental Field	42
Sowing of Maize Inbred Lines and Raising of Seedlings	44
Intercultural Operation and Disease Control	44
Collection of Data	44
Collection of Data on Harvesting and Cob Related Characters	45
Techniques of Statistical Analysis of Data	49
(i) Mean	50
(ii) Standard deviation (SD)	50

(iii) Standard error of mean (SE)	50
(iv) Coefficient of variability in percentage	51
(v) Analysis of variance	51
(vi) Components of variation	54
(vii) Estimation of genotypic and phenotypic coefficient of variation	54
(viii) Heritability (h^2_b)	55
(ix) Genetic advance (GA)	55
(x) Genetic advance in percentage of mean (GA %)	55
(xi) Analysis of covariance	56
(xii) Correlation coefficient	57
(xiii) Path coefficient	58
(xiv) Selection index	59
(xv) Genetic divergence	61
EXPERIMENT II	62
3.2.1 MATERIALS	
3.2.2 METHODS	62
Field Experiment	62
Collection of Data	62
Techniques of Statistical Analysis of Data	62
(i) Diallel and Combining Ability Analysis	62
Testing the significance differences	63
Estimation of variance and covariance	64
Testing the validity of the hypothesis	65
Components of variation and their proportions	66
Graphical analysis	68
Combining ability analysis	68

(ii) Heterosis Study	69
Estimation of mid-parent and better-parent	69
Test of significance for heterosis	71
CHAPTER 4	72-141
RESULTS	
EXPERIMENT I	72
4.1.1 GENETIC VARIABILITY	
Mean with Standard Error and Coefficient of Variability	72
Analysis of Variance	81
Genetic Parameters	82
(i) Phenotypic Variation (σ^2_p)	82
(ii) Genotypic Variation (σ^2_g)	82
(iii) Error Variation (σ^2_e)	83
(iv) Coefficient of Variability	83
(v) Heritability (h^2_b), Genetic advance (GA) and Genetic advance in percentage of mean (GA %)	83
4.1.2 CORRELATION COEFFICIENT	85
Genotypic Correlation Coefficient Between Grain Yield and its Components	85
Phenotypic Correlation Coefficient Between Grain Yield and its Components	86
Genotypic Correlation Coefficient Between Different Pairs of Characters	86
Phenotypic Correlation Coefficient Between Different Pairs of Characters	88
4.1.3 PATH COEFFICIENT ANALYSIS	89
Path Coefficient at Genotypic Level	89
Path Coefficient at Phenotypic Level	92

4.1.4 SELECTION INDEX	98
4.1.5 GENETIC DIVERGENCE ANALYSIS	105
Cluster Analysis	105
Canonical Variate Analysis	105
Cluster Means	106
Contribution of Characters Towards Divergence of the Inbred Lines	106
EXPERIMENT II	
4.2.1 DIALLEL ANALYSIS	109
Mean Performance of F₁ Hybrids Involving 25 Inbred Lines	109
Testing the Validity of the Hypothesis	110
Genetic Components of Variation and Their Proportions	110
Graphical Analysis (Wr-Vr graph)	111
4.2.2 COMBINING ABILITY FOR GRAIN YIELD AND YIELD COMPONENTS	125
Variance Analysis	125
General Combining Ability	125
Specific Combining Ability	127
4.2.3 HETEROSIS STUDY	134
Estimation of Mid-parent and Better-parent	134
CHAPTER 5	142-156
DISCUSSION	
GENETIC VARIABILITY	142
CORRELATION COEFFICIENT	143
PATH COEFFICIENT	144
SELECTION INDEX	145
GENETIC DIVERGENCE	146
DIALLEL AND COMBINING ABILITY	148

HETEROSIS	154
CHAPTER 6	157-161
SUMMARY AND CONCLUSION	
CHAPTER 7	162-192
REFERENCES	

LIST OF TABLES

Table No.	Title	Page No.
3.1.2.1.	Analysis of variance (ANOVA)	53
3.1.2.2.	Analysis of covariance	57
3.2.1.1.	Preparation of ANOVA	64
3.2.1.2.	ANOVA for combining ability in method I	68
4.1.1.	Mean with SE, CV % for days to tasseling and days to silking of 25 inbred lines of maize	75
4.1.2.	Mean with SE, CV % for days to maturity and plant height(cm) of 25 inbred lines of maize	76
4.1.3.	Mean with SE, CV % for ear height (cm) and cob diameter (cm) of 25 inbred lines of maize	77
4.1.4.	Mean with SE, CV % for cob length (cm) and for number of row/cob of 25 inbred lines of maize	78
4.1.5.	Mean with SE, CV % for number of kernels/row and number of grains/cob of 25 inbred lines of maize	79
4.1.6.	Mean with SE, CV % for grain yield/plant (g) of 25 inbred lines of maize	80
4.1.7.	Analysis of variance for days to tasselling, days to silking, days to maturity and plant height of 25 inbred lines of maize	81
4.1.8.	Analysis of variance for ear height, cob diameter, cob length and number of rows/cob of 25 inbred lines of maize	81
4.1.9.	Analysis of variance for number of kernels/row, and number of kernels/cob of 25 inbred lines of maize	82
4.1.10.	Estimation of genetic parameters for grain yields and yield components in maize inbred	85
4.1.11.	Genotypic and phenotypic correlation coefficients between grain yield/plant and yield contributing characters in maize	86
4.1.12.	Genotypic correlation coefficient (r_g) between different pairs of characters in maize	87

Table No.	Title	Page No.
4.1.13.	Phenotypic correlation coefficient (r_p) between different pairs of characters in maize	89
4.1.14.	Path coefficient analysis showing direct and indirect effects of yield components on grain yield/plant of maize at genotypic level	92
4.1.15.	Path coefficient analysis showing direct and indirect effects of yield components on grain yield/plant of maize at phenotypic level	95
4.1.16.	Expected gain in percentage of grain yield over selection from the use of various selection indices in maize inbred lines	100-104
4.1.17.	Distribution of 25 maize inbred lines in five different clusters	107
4.1.18.	Inter and intra-cluster (bold) distance (D^2) for 25 maize inbred lines obtained by canonical variate analysis	107
4.1.19.	Cluster means for 11 characters of 25 maize inbred lines	108
4.1.20.	Relative contributions of 11 characters to the total divergence in maize	108
4.2.1.	Mean performances of 21 F_1 hybrids in 6×6 diallel crosses in maize	115
4.2.2.	Components of variation and their proportions for days to tasseling	116
4.2.3.	Components of variation and their proportions for days to silking	116
4.2.4.	Components of variation and their proportions for days to maturity	116
4.2.5.	Components of variation and their proportions for plant height	117
4.2.6.	Components of variation and their proportions for ear height	117
4.2.7.	Components of variation and their proportions for cob length	117
4.2.8.	Components of variation and their proportions for cob diameter	118
4.2.9.	Components of variation and their proportions for number of rows/cob	118

Table No.	Title	Page No.
4.2.10.	Components of variation and their proportions for number of kernels/row	118
4.2.11.	Components of variation and their proportions for number of grains/cob	119
4.2.12.	Components of variation and their proportions for grain yield/plant	119
4.2.13.	Analysis of variance for combining ability analysis for grain yield and its components in 6×6 diallel cross in maize	129
4.2.14.	Estimation of GCA effects of the parents for different characters in maize	130
4.2.15.	Specific combining ability (SCA) effect for days to tasseling in 6×6 diallel cross in maize	130
4.2.16.	Specific combining ability effect for days to silking in 6×6 diallel cross in maize	130
4.2.17.	Specific combining ability effect for days to maturity in 6×6 diallel cross in maize	131
4.2.18.	Specific combining ability effect for plant height in 6×6 diallel cross in maize	131
4.2.19.	Specific combining ability effect for ear height in 6×6 diallel crosses in maize	131
4.2.20.	Specific combining ability effect for cob length in 6×6 diallel crosses in maize	132
4.2.21.	Specific combining ability effect for cob diameter in 6×6 diallel crosses in maize	132
4.2.22.	Specific combining ability effect for number of rows/cob in 6×6 diallel cross in maize	132
4.2.23.	Specific combining ability effect for number of kernels/row in 6×6 diallel cross in maize	133
4.2.24.	Specific combining ability effect for number of grains/cob in 6×6 diallel cross in maize	133
4.2.25.	Specific combining ability effect for grain yield/plant in 6×6 diallel cross in maize	133

Table No.	Title	Page No.
4.2.26.	Heterotic effect in F ₁ generation over mid parent and better parent for days to tasseling and days to silking	136
4.2.27.	Heterotic effect in F ₁ generation over mid parent and better parent for days to maturity and plant height	137
4.2.28.	Heterotic effect in F ₁ generation over mid and better parent for ear height and cob length	138
4.2.29.	Heterotic effect in F ₁ generation over mid and better parent for cob diameter and number of rows/cob	139
4.2.30.	Heterotic effect in F ₁ generation over mid and better parent for number of kernels/row and number of grains/cob	140
4.2.31.	Heterotic effect in F ₁ generation over mid and better parent for grain yield/plant	141

LIST OF FIGURES

Figure No.	Title	Page No.
3.1.1	Design of the experimental field	43
4.1.1.	Path diagram of different grain yield contributing characters on yield at phenotypic level	96
4.1.2.	Path diagram of different grain yield contributing characters on yield at genotypic level	97

LIST OF GRAPHS

Graph No.	Title	Page No.
4.2.1.	Vr–Wr graph for days to tasseling in 6x6 diallel cross in maize	120
4.2.2.	Vr–Wr graph for days to silking in 6x6 diallel crosses in maize	120
4.2.3.	Vr–Wr graph for days to maturity in 6x6 diallel crosses in maize	121
4.2.4.	Vr–Wr graph for plant height in 6x6 diallel crosses in maize	121
4.2.5.	Vr–Wr graph for ear height in 6x6 diallel crosses in maize	122
4.2.6.	Vr–Wr graph for cob diameter in 6x6 diallel crosses in maize	122
4.2.7.	Vr–Wr graph for cob length in 6x6 diallel crosses in maize	123
4.2.8.	Vr–Wr graph for number of rows/cob in 6x6 diallel crosses in maize	123
4.2.9.	Vr–Wr graph for number of kernels/row in 6x6 diallel crosses in maize	124
4.2.10.	Vr–Wr graph for number of grains/cob in 6x6 diallel crosses in maize	124
4.2.11.	Vr–Wr graph for GYP in 6x6 diallel crosses in maize	124

LIST OF PLATES

Plate No.	Title	Page No.
1	Plate No. 1: Different stages of inbreds and crossing block	47
2	Plate No. 2: F ₁ seeds and F ₁ plants	48

ABSTRACT

The present study was carried out during 2008/2009, 2009/2010 and 2010/2011 to obtain information about the performance of maize inbred lines, genetic diversity, gene action and assessment of the combining ability of parental lines and their F₁s by using diallel fashion. Genetic variability analysis revealed that days to maturity, plant height and number of rows/cob had higher variability, heritability and genetic advance in percentage of mean. Broad-sense heritability estimates of the characters were higher in magnitude (66.08 to 93.41%) indicating greater genetic impact on these characters. Positive significant phenotypic and genotypic correlations were found for days to maturity, number of kernels/row and number of grains/cob. The path analysis revealed that number of rows/cob, cob length and number of kernels/row had the highest direct effect on grain yield, while plant height and ear height and number of grains/cob had the highest moderate indirect negative effects on grain yield. Selection indices were constructed through the discriminate function using nine characters. From the results, the highest relative efficiency was observed with the selection index based on four characters viz., ear height, number of rows/cob, number of kernels/row and grain yield/plant. Cob length, number of kernels/row and number of grains/cob could be the important selection criteria in the improvement of maize lines and hybrids for higher grain yield. The average inter-cluster was always higher than the average intra-cluster distance suggesting wider genetic diversity among the inbred lines of the groups. Cluster III had the highest intra and inter-cluster distance was maximum between clusters I and II. So, the inbred lines chosen from these clusters would give broad spectrum of variability in the segregating generation.

A half diallel set of six maize inbred lines were utilized to evaluate combining ability and heterosis for yield and its components characters. General and specific combining ability effects were significantly different among the parental lines. The parents P₅ and P₄ were considered suitable according to their yield capacities

and general combining ability effects. The variances for general (gca) and specific (sca) combining ability for plant height, cob diameter and number of rows/cob were highly significant indicating the presence of additive as well as non-additive gene effects for controlling the characters.

In the present study the values of F for all the characters except cob diameter were positive and greater than zero, which expressed that dominant alleles were more frequent than recessive alleles. The estimate of additive genetic variance (D) was significant for days to silking, days to maturity, ear height and number of rows/cob indicating the importance of additive gene effect in their inheritance. Thus highly significant values of the components D, H₁ and H₂ indicated the importance of both additive and dominant gene effect for the characters under study. The ratio of $[4DH_1]^{1/2} + F / [4DH_1]^{1/2} - F$ estimates the relative proportion of dominant and recessive alleles in the parents. From W_r-V_r graph it has been noticed that expression of dominant and recessive alleles in the parents was influenced by environment as the same parent showed different positions on graphs. From this study, it is concluded that parents with recessive and dominant genes can also contribute towards high yield.

The mid parent heterosis values ranged from 1.73% (P₁×P₆) to 5.21% (P₁×P₂) whereas, the useful heterosis values varied between -40.36% (P₁×P₅) and 4.94% (P₁×P₂), and only five crosses had higher grain yield. Of these crosses, P₁×P₂, P₂×P₅, P₄×P₅ and P₅×P₆ were considered promising hybrids and will be tested in yield trials for further evaluation. Taking the lines of these promising crosses into account, parents P₅ and P₄ may be used as parents in hybrid maize programs. In addition to these parents, P₃ with dominant genes, high yield and general combining ability may be recommended as another parent.

ACRONYMS

BBS	=	Bangladesh Bureau of Statistics
cm	=	centimeter
df	=	degrees of freedom
<i>et al.</i>	=	and others
FAO	=	Food and Agriculture organization
Fig.	=	Figure
g	=	Gram
ha	=	hectare
i.e	=	that is
m	=	Meter
m ²	=	Square Meter
mm	=	Millimeter
S	=	Significant
R (R ₁ , R ₂ , R ₃)	=	Replication
NS	=	Not Significant
t	=	Ton
viz.	=	Namely
%	=	Percentage
/	=	Per

INTRODUCTION

Maize (*Zea mays* L.; $2n=20$) is an important cereal crop with high yield potential. Maize stands third among the cereal crops in Bangladesh after rice and wheat (BBS, 2009). It can be grown throughout the year because of its photo-insensitiveness. World wide maize ranks first in terms of production and yield but third in terms of area, next to wheat and rice (FAO, 2009). In Bangladesh, maize has emerged as a third important cereal due to its versatile uses. On global front, maize has gained tremendous importance due to rising demand from diversified sectors like food, feed and ethanol production. Maize is considered the third cereal crop after rice and wheat all over the world for production and consumption. In addition to its use as a human food, it is also utilized as a poultry and livestock feed and also as a fodder (White and Johnson, 2003). Maize is used as staple food in many countries of the world although its uses as human food are very limited in Bangladesh. Maize plays a significant role in human and livestock nutrition world wide (Bantle and Prasanna, 2004). In Bangladesh, area, production and yield of maize decreased by 2.9%, 3.59% and 0.69%, respectively from the year 1967-68 to 1986-87 due to utilization of traditional variety (Mohiuddin, 2003).

Introduction of hybrid varieties and appropriate management practices increased area, production and yield by 19.83%, 34.40% and 14.56%, respectively from the year 1987-88 to 2003-2004 (Moniruzzaman *et al.*, 2007). Now maize has become an important cereal in terms of yield (Maize: 5.36., wheat: 2.21; and rice: 2.15 ton/ha., Anonymous, 2003) but in terms of area and production, it could be good source of nutrients for under-nourished and mal-nourished populations in Bangladesh. From the trends of its increasing demand, yield, acreage and production in recent years it seems that maize is going to hold the second position next to rice in a few years.

Although maize research started in the early 1970's, its acreage and production did not increase much until the mid 1990's. With the introduction of hybrid varieties and recent growth of poultry industries, maize cultivation has expanded faster than any crop in the past. The present production is above 23 million tons from around 4 million hectares of land producing at a rate of 6 tons per hectare (Rashid *et al.*, 2010). With the introduction of hybrid maize varieties in the country the prospect of maize cultivation has become bright. Maize is a unique crop because of its versatile use and low cost per unit production. Maize is consumed either directly or indirectly by millions of people. About 75% of maize is fed to animal, thus, indirect consumption is greater than direct consumption. Demand of maize is likely to progressively increase in near future. In order to fulfill the demand of additional food and to maintain self-sufficiency in food of Bangladesh, maize can be considered as a supplementary food to rice.

The development of hybrid varieties and production of hybrid maize seeds is therefore, very important. Hybrid seed production requires development and selection of suitable inbred parents. Moreover, due to industrialization, urbanization and river erosion, 221 hectares of crop land is losing every day (Banik *et al.*, 2009). So, production of more food from limited land is essential and it is not possible to get required quantity of food from rice and wheat only. Maize is the crop which can fulfil the demand. Bangladesh is a rice consuming country. People of Bangladesh have changed their food habit to some extent and consuming wheat also. The climatic condition of Bangladesh is suitable for maize cultivation. That is why the acreage, production and yield of maize is increasing steadily and maize is becoming important crop in Bangladesh.

In working towards this goal, particular attention is paid to grain yield as the most important agronomic characteristic. Grain yield is a complex quantitative trait that depends on a number of factors. It is under great influence of environmental

conditions, has complex mode of inheritance and low heritability (Bocanski *et al.*, 2009). Most of the yield components are less complex, and because of that using some other traits which are highly correlated with grain yield and has higher heritability, would make the selection of the best progenies more reliable (Vasic *et al.*, 2001; Bekavac *et al.*, 2007, 2008). Because of that during selection of grain yield, in order to select the best individuals, we need to determine the mean values, components of variance and heritability of the studied traits. Besides, knowing the correlations between the characters is also of great importance for success in selection to be conducted in breeding programs, and analysis of correlation coefficient is the most widely used one among numerous methods that can be used (Yagdi and Sozen, 2009). Because correlation coefficient measures the mutual association only between a pair of variables, when more than two variables are involved, the correlations *per se* may not provide a clear picture of the importance of each component in determining grain yield. The appropriate knowledge of such interrelations between grain yield and its contributing components can significantly improve the efficiency of breeding programme through the use of appropriate selection indices (Mohammadia *et al.*, 2003). Assuming yield is a contribution of several characters which are correlated among themselves and to the yield, path coefficient analysis was developed (Wright, 1923; Dewey and Lu, 1959). Unlike the correlation coefficient which measures the extent of relationship, path coefficient measures, the magnitude of direct and indirect contribution of a component character to a complex character and it has been defined as a standardized regression coefficient which splits the correlation coefficient into direct and indirect effects. Path coefficient analysis provides more information among the variables that do correlation coefficients since this analysis provides the direct effects of specific yield components on yield, and indirect effects via other yield components (Garcia del Moral *et al.*, 2003). Because yield is a quantitative character and is

associated with other component characters which are influenced to varying degree by the fluctuations in the environmental conditions (Chaugale, 1967).

A complete satisfactory criterion based on discriminant function selection would be more desirable when a combination of two or more characters with yield is studied in a selection index. The use of selection index technique would serve a two-fold purpose: (1) to bring about the genetic progress simultaneously in several characters and (2) to improve the yield through selection for relatively more heritable auxiliary characters. The technique of discriminant function analysis was first developed by Fisher (1936) and adopted for plant selection by Smith (1936). Later on, different workers constructed selection indices for different crops, such as Robinson *et al.* (1951) worked on corn; Paroda and Joshi (1970) on wheat; Joarder *et al.* (1978), Samad (1991) on rapeseed, Hussain (1997) on chilli and Ferdous *et al.* (2010) on wheat. The demand for food is on the rise due to the growth of the human population. The global maize stocks that have been shrinking uninterruptedly over the last 5 years already reflected the increased demand (Dias, 2005).

The development of improved varieties with high yield potential can be seen as a possibility to increase production. Such varieties with qualitative and/or quantitative superior traits over previously recommended varieties are developed by genetic improvement, which represents one of the most successful modern technologies in agriculture, and accounts for approximately 50 % of the yield increments of most crops (Fehr, 1987). To obtain genetic gains in different traits there are some methodologies of simultaneous selection (Cruz and Carneiro, 2003). Of these, the selection index proposed by Smith (1936) and Hazel (1943) has been well-accepted in maize improvement programmes. This index associates the information of different traits of agronomic interest, based on economic weights, genotypic and phenotypic variances of each trait and the respective covariances. Construction of selection

indices and their analysis would give the most appropriate weightage to the phenotypic values of each of two or more characters to be used simultaneously for selection (Ferdous *et al.*, 2010).

Genetic diversity is one of the useful tools to select appropriate lines for hybridization. Precise information on the nature and degree of genetic diversity helps the plant breeder in choosing the diverse parents for purposeful hybridization (Samsuddin, 1985). The genetic diversity between the lines is important as the genetically diverged parents are able to produce high heterotic effects (Falconer, 1981; Arunachalam, 1981; Ghaderi *et al.*, 1984; Mian and Bahl, 1989). Maize breeders are consistently emphasizing the importance of diversity among the parental genotypes as a significant factor contributing to heterotic hybrids (Ahloowalia and Dhawan, 1963). D^2 analysis is a useful tool for quantifying the degree of divergence between biological population at genotypic level and in assessing relative contribution of different components to the total divergence both intra and inter-cluster level. Genetic divergence analysis estimates the extent of diversity existed among the selected genotypes (Murty and Arunachalam, 1966; Ram and Panwar, 1970; Sachan and Sharma, 1971 and Mondal, 2003).

The concept of general combining ability and specific combining ability was introduced by Sprague and Tatum (1942) and its mathematical modeling was set about by Griffing (1956) in his classical paper in conjunction with the diallel crosses. The value of any population depends on its potential *per se* and its combining ability in crosses (Vacaro *et al.*, 2002). The usefulness of these concepts for the characterization of an inbred in crosses have been increasingly popular among the maize breeders since the last few decades. Combining ability is a powerful tool in identifying the best combiners for hybridization especially, when a large number of advanced inbred lines are available and most promising ones are to be selected on the basis of their ability to give superior quality maize hybrids. Information on heterotic patterns and

combining ability among the maize germplasms is essential in maximizing the effectiveness of hybrid development (Beck *et al.*, 1990). Development of commercial maize hybrid usually requires a good knowledge of combining ability of the breeding materials to be used. The success in commercial production of hybrid maize depends on the availability of productive diverse quality maize inbred lines and clear knowledge of gene action for specific characters. The nature and magnitude of gene action is an important factor in developing an effective breeding program. Combining ability analysis is useful to assess the potential inbred lines and also helps in identifying the nature of gene action involved in various quantitative characters. A series of combining ability studies have been made by many workers from the International Maize and Wheat Improvement Centre (CYMMIT) to establish heterotic patterns among several maize check populations and gene pools, and to maximize their yield for hybrid development (Beck *et al.*, 1990, 1991; Crossa *et al.*, 1990; Vasal *et al.*, 1992a). Likewise, the variances of general and specific combining ability are related to the type of gene action involved. Variance for GCA includes additive portion while that of SCA includes non-additive portion of the total variance arising largely from dominance and epistatic deviations (Rojas and Sprague, 1952).

Diallel crosses were devised, specifically, to investigate the combining ability of the parental lines for the purpose of identification of superior parents for use in hybrid development programmes (Malik *et al.*, 2004). Analysis of diallel data is usually conducted according to the methods of Griffing (1956) which partition the total variation of diallel data into GCA of the parents and SCA of the crosses (Yan and Hunt, 2002).

Combining ability describes the breeding values of parental lines to produce hybrids. Sprague and Tatum (1942) used the term GCA to designate the average performance of a line in hybrid combinations, and used the term SCA to define those cases in which certain combinations do relatively better or

worse than would be expected on the basis of the average performance of the lines involved. In many studies, GCA effects for parents and SCA effects for crosses were estimated in maize (Dehghanpour *et al.*, 1996; San-Vicente *et al.*, 1998; Konak *et al.*, 1999; Chaudhary *et al.*, 2000; Araujo and Miranda, 2001; Kalla *et al.*, 2001).

Heterosis breeding using best combiners is one of the methods to improve upon the existing lines. Information on the genetic structure of a set of parents and mode of gene action governing yield and its attributes could be useful in designing suitable breeding procedures. For genetic studies various workers had used different biometrical methods but amongst them the approach of Hayman (1954a) and Mather and Jinks (1971) had been followed frequently. Genetic analysis of some economic traits showed different pattern of inheritance. The combining ability analysis helps in classifying the parents in terms of their hybrid performance and in gaining greater understanding of the nature of quantitatively inherited trait (Abd El-Aty and Katta., 2002; Ahmed and Saleem, 2003; El- Borhamy, 2004 and Ahmed *et al.*, 2011).

The most limiting factors of maize research in Bangladesh are the development, improvement and maintenance of parental/inbred lines. On the other hand, the problems of imported hybrid seed are the introduction of high price and uncontrolled quality. Moreover, the farmers can not get the seeds timely. One important approach to improve this situation is the development of inbred lines which can produce high yielding hybrid varieties. Before hybrid development, prospective parent (inbred line) selection is a pre-requisite. Several studies on maize have shown that inbred line from diverse stocks tend to be more productive than crosses between inbred lines from the same variety (Vasal, 1992b). Development of suitable inbred parents based on the genetic variability, diversity and combining ability for the production of hybrid seeds have been used as an important breeding approach in maize improvement.

A diallel analysis provides good information on the genetic identity of genotypes especially on dominance-recessive relations and some other genetic interactions. Diallel crosses have been used in genetic research to determine the inheritance of a trait among a set of genotypes and to identify superior parents for hybrid or cultivar development (Weikai Yan and Manjit Kang, 2003).

Heterosis and combining ability is one of the powerful tools in identifying the best combiner that can be used in crosses either to exploit heterosis or to accumulate fixable genes. Genetic diversity and combining ability of lines are important to obtain high heterosis values in the formation of maize hybrids (Sallahuddin, 2008). For developing desirable hybrids, information about combining ability of the parents and the resulting crosses is essential. (Banik, 2008).

One important approach to improve this situation is the development of inbred lines which can produce high yielding hybrid varieties. Before hybrid development, prospective parent (inbred line) selection is a pre-requisite. An inbred line is a “pure line” developed by self-pollination and selection until apparently homozygous plants are obtained. This usually requires five to seven generations of inbreeding. After five to seven generations of inbreeding and vigorous selection, vigorous inbred lines, uniform in appearance, are developed. Each inbred will have a different combination of genes. The main goal of maize breeding is to develop potential lines that ensure highest and stable production in a range of environments.

Therefore, we require stable inbred lines, which can help in the development of stable hybrids/varieties.

Keeping these points in view the present study was planned and executed with the following objectives.

- i. To evaluate and screen out the suitable inbred lines for yield parameters for their *per se* performance.

- ii. To study the nature and magnitude of genetic variability, heritability and genetic advance as per cent of mean for grain and yield contributing traits.
- iii. To study the association between quantitative characters and grain yield, between grain and yield component characters.
- iv. To estimate the contribution of yield component characters to the grain through the path coefficient analysis.
- v. To study the genetic divergence exists among the 25 maize inbred lines
- vii. To study the combining ability to identify good combining inbreds as well as their high heterotic hybrid combination.
- viii. To know the mode of gene action in governing the characters.
- ix. Study of inheritance pattern and mode of gene action for various yield contributing characters and positions of parents along the regression line on graph
- x. To select the superior parent/line suitable for commercial cultivation in Bangladesh.

REVIEW OF LITERATURE

In maize, a lot of work has been done all over the world on genetic parameters. However, only selected reports on genetic variability, character association, selection index, divergence, combining ability, heterosis and genetic components of variation in maize inbred lines of some traits which are relevant to this work, are included in this review.

GENETIC VARIABILITY

In designing a breeding programme it is essential to have a critical survey of genetic variability of inbred lines available. Burton (1952) suggested that a genetic coefficient of variation together with a heritability estimate would likely to give the best picture of the amount of genetic advancement to be expected from selection. On the other hand, Johnson *et al.* (1955) reported that heritability estimates along with genetic gain were more useful in predicting the effect of selection of the best individual. If heritability is mainly owing to the non-additive gene effect, the expected gain would be low; but if it is owing to additive gene effect, a high genetic advance may be expected.

Swamy *et al.* (1970) reported moderate to high heritability estimates of 55.55 and 86.04 percent for ear diameter, whereas Patil *et al.* (1972) noticed moderate heritability of 68.88 per cent for plant height trait and a value of 27.45 per cent for ear length. Johnson (1981) reported moderate to high range of heritability for 100 grain weight. However, Shahi and Singh (1985) reported high heritability for days to flowering, plant height and ear height. The expected genetic gain was about 17 per cent for plant height and 12 per cent for ear height in one of the locations. Bhalla *et al.* (1986) in their study reported high heritability estimates associated with high genetic advance for grain yield per plant, ear height, number of kernel rows per cob and plant height.

Debnath (1987) found that heritability was high for plant height and ear height, but low for the remaining characters. Expected genetic advance was high for grain yield, plant height and ear height. High heritability estimate of 70 per cent for plant height in 3-way cross hybrid maize was noticed by Debnath *et al.* (1988) and Mahmoud *et al.* (1990) noticed high heritability for ear diameter and number of kernels row per ear in maize. Arha *et al.* (1990) and Mani and Bisht (1996) found moderate heritability for grain yield, ear height and moderate for plant height. High heritability estimates for ear height was also noticed by Reddy and Agrawal (1992). Stem thickness showed the highest narrow sense heritability followed by ear position, thousand grain weight and ear girth. El-Hosary *et al.* (1994) noticed moderate to broad sense heritability values for ear height.

Ali *et al.* (1994) observed the highest genotypic variations for 1000-grain weight but minimum genetic advance in 32 genotypes of maize. Genotypic coefficient of variation, heritability and genetic advance are high for grain yield in maize as reported by most of the previous workers (Ali *et al.*, 1994; Singh *et al.*, 1995; Mani and Bisht, 1996; Satyanarayana and Saikumar, 1996; Ali *et al.*, 1997; Akanda *et al.*, 1997 and 1998; Tiwari and Verma, 1999; Singha and Prodhan, 2000 and Alam, 2009). On the contrary, Satyanarayana and Saikumar (1995) reported low genotypic coefficient of variation estimates combined with medium heritability and low genetic advance for grain yield.

Altinbos (1995) reported low heritability estimates and suggested that selection for ear length and ear diameter in early generations. Saxena *et al.* (1996) noted high heritability for plant height, ear height, ear girth and kernel rows per ear and low for grain yield, ear length and number of kernels per row. Maximum genetic gain was reported for ear height. The estimation of broad sense heritability is useful to predict the response even though it has got some

limitations. Mani and Bisht (1996) also reported high genetic advance for plant height. But Arha *et al.* (1990) found moderate heritability and genetic advance for plant height.

However, Mani and Bisht (1996) reported that genotypic coefficient of variation revealed low genetic variability for the ear girth in 38 local germplasms of maize. High genotypic coefficient of variation and heritability coupled with high genetic advance for grains/row has been reported by Akanda *et al.* (1997), Ali *et al.* (1997) and Singh *et al.* (1998).

Ali *et al.* (1997) reported high genotypic and phenotypic coefficient of variation for ear length. As an important yield attributing character, variability of ear girth has been studied. They also reported high genetic advance accompanied by high heritability for ear breadth.

Akanda *et al.* (1998) reported that genotypic and phenotypic coefficient of variation, heritability and genetic advance were moderate for ear girth. Contrarily, They reported comparatively low genotypic coefficient of variation and heritability and genetic advance for the same character.

Genotypic coefficient of variation, heritability and genetic advance are high for 1000-kernel weight reported by Ali *et al.* (1997), Singh *et al.* (1998) and Akanda *et al.* (1997 and 1998). Akanda *et al.* (1997, 1998) and Singha and Prodhan (2000) reported that heritability along with genetic advance and genotypic coefficient of variation was high for ear size and ear length.

Singh and Dashi (2000) reported high heritability and genetic advance for plant height. Singha and Prodhan (2000) reported high heritability along with high genetic advance and high genotypic coefficient of variation for ear height in 34 genotypes of maize. Rafiq *et al.* (2010) reported that grain yield, ear length, ear height, 100-seed weight and ear diameter had high GCA estimates with high heritability. Genetic advance was higher for plant height, ear length, grains per row and grain yield.

Shamim *et al.* (2010) studied that broad sense heritability estimates for plant height, cob length, grains/row, 1000-grain weight and harvest index were higher in magnitude (61.0 to 99.0%) indicating greater genetic impact on these traits.

Wannows *et al.* (2010) showed that high narrow sense heritability estimates were detected for leaf area index, number of kernel per row, plant height, ear height, physiological maturity, number of rows per ear, ear length and ear diameter and emphasizing that the additive genetic variance was the major component of genetic variation in the inheritance of these traits and would likely be in selection of improving these traits.

CORRELATION AND PATH COEFFICIENT

Grain yield in maize as in other crop is associated with a number of yield components. A study of the nature and degree of association of these components with yield assumes greater importance for fixing up characters that play a decisive role in influencing yield. Selection would therefore be more effective if it is based on component characters rather than directly on grain yield. According to Appadurai and Nagarajan (1975), grain weight per ear and grain numbers per row had little effect on yield, while ear length and ear circumference had positive correlation with yield. Kim (1975) and Hallauer *et al.* (1989) reported correlation coefficients among the characters were generally positive and significant for plant height and ear height.

Probecky (1976) reported that grain yield primarily depends on the number of grains per plant; which in turn depend mainly on the number of grains in the rows. Utkhede and Shukla (1976) revealed highly significant positive genotypic and phenotypic correlation between yield and number of grain row per ear, weight of ear, ear height and ear length. Ear height and dry ear weight contributed substantially to yield. Singh and Nigam (1977) found that grain yield was positively and significantly correlated with five yield components

i.e., 100 grain weight, number of kernel rows per cob, ear weight, ear diameter and number of grain per rows. Sharma *et al.* (1982) reported that grain yield was positively correlated with grains per ear, hundred grain weight, plant height and ear height. Saha and Mukherjee (1985) observed that grain yield per plant was significantly correlated with ovules per ear, grains per ear and 100-grain weight.

Malhotra and Khehra (1986) recorded positive correlation between grain yield and yield components like ear length, ear circumference, number of rows per ear, 1000-grain weight, shelling percentage, ear height and plant height. Tyagi *et al.* (1988) opined that grain yield was influenced more by ear weight, ear length, plant height, kernels per row and 100 grain weight. Maharajan *et al.* (1990) concluded that grain yield was positively correlated with ear length, number of kernels per row and plant height. Singh *et al.* (1991) noted that grain yield per plant had significant positive correlations with plant height and ear height in F₁ and F₂ generations under alkaline soil and with leaf area in both the generations under normal soil. Debnath and Khan (1991) revealed that plant height, number of kernels per row and 1000-grain weight had strong positive contributions to grain yield.

Boraneog and Duara (1993) observed that plant height and ear height exhibited significant positive correlation with grain yield. Saha and Mukherjee (1993) reported positive significant correlation between grain yield per plant with 100-grain weight, ear length, ear circumference, number of kernel rows per ear and number of kernels per row, the ear circumference and number of grains per row. Krishnan and Natarajan (1995) obtained high positive association between grain yield and plant height, ear length, ear weight and number of kernels per row. Rahman *et al.* (1995) reported that grain yield was significantly and positively correlated with plant height, ear height, number of grains per ear and 1000 grain weight. According to Satyanarayana and Saikaman (1996), grain

yield was positively correlated with number of kernel rows per ear, ear length, ear circumference and 100 grain weight. Kumar and Kumar (1997) reported that values of genotypic correlation were slightly higher than the corresponding phenotypic values. Significant positive correlation was recorded for plant height, ear length and ear height with yield per plant. Annapurna *et al.* (1998) reported that seed yield was positively and significantly correlated with plant height, ear circumference, number of seeds per row, number of seed rows per ear.

Khakim *et al.* (1998) noticed that grain yield was positively correlated with plant and ear insertion height, leaf area, ear number, ear length, number of kernel rows per cob, number of grains per row and grain weight per cob, ear weight and 1000-grain weight.

Gautam *et al.* (1998) reported maximum correlation between grain yield and number of kernels per row, leaf area, plant height and cob length. Dutu (1999) indicated that at phenotypic and genotypic levels, growth period was strongly correlated with plant height and leaf numbers. He also reported correlations using the date of flowering, plant height and the number of leaves which were used as indirect selection criteria and resulted in positive correlated response in earliness and yielding potential.

Basheruddin *et al.* (1999) reported that correlation coefficients had highly positive significant influence on plant height, number of leaves, leaf area per plant and stem girth. Nawar *et al.* (1999) observed that additive components were significant for number of kernel rows per cob. Highly significant positive correlation coefficients were detected among yield per plant, components of ear and plant height. Kumar (1999) revealed that the number of grains per row, number of rows per ear, ear circumference and ear length had direct effect on grain yield.

Mani *et al.* (2000) reported that grain yield per plant indicated that highly significant positive correlation with all the attributes and was highest with ear weight per plant. Umakanth *et al.* (2000) observed that grain yield per plot showed significant and positive correlations with ear circumference, ear length, plant height and 100-seed weight. Path analysis revealed that plant height followed by number of seeds per row, 100-seed weight, ear length and ear circumference showed maximum positive direct genotypic effects as well as indirect contribution through other characters on grain yield.

Vaezi *et al.* (2000) noticed that grain yield was significantly and positively correlated to ear weight, ear circumference, number of kernel rows per cob and number of kernels per row. Netaji *et al.* (2000) reported that yield per plot was significantly and positively correlated with all the characters except days to 50 per cent tasseling, silking and dry husk. Maximum variability was observed for plant height, followed by ear height and test weight. Singh and Dashi (2000) revealed high positive correlation of green fodder yield with plant height, leaf length and leaf stem ratio. Prodhan and Rai (2000) reported that significant positive correlation of popping expansion was found with popping percentage, tenderness and pericarp thickness, while popping expansion showed significant negative association with grain weight and non-significant negative association with grain yield. On the other hand, grain yield was strongly associated with grain weight.

Geetha and Jayaraman (2000) observed number of grains per row exerted a maximum direct effect on grain yield. Vaezi *et al.* (2000) showed that 300-kernel weight and kernel depth had the highest positive effect on grain yield whereas ear diameter had a negative indirect effect on grain yield through some traits. Path analysis, for grain yield showed that kernel weight and kernel depth had the highest positive effect on grain yield. Kumar and Satyanarayana (2001) concluded that grain yield was positively associated with plant height, ear

height, ear length, ear circumference, number of seed rows per ear and test weight. Swarnalatha and Mohammad (2001) indicated that the plant height, days to 75 per cent silking and maturity, ear length, number of seeds per row and 100-grain weight positively influenced the yield directly and also indirectly through several yield components. Guang Cheng *et al.* (2002) showed that importance of eight yield components to grain yield and suggested that more attention should be paid to cob length, cob diameter and kernel percentage. They also noticed that grain yield per plot had significant positive correlation with 100-kernel weight.

Venugopal *et al.* (2003) indicated that plant height, ear height, ear length, ear girth, 100-seed weight and number of seeds per row were positively associated with grain yield. Although the character number of seed rows per ear had a direct positive contribution towards grain yield, but it had indirect negative influence through ear length, 100 seed weight and number of seeds per row.

Ahmad and Saleem (2003) reported that vegetative phase had the highest positive direct contribution to grain yield per plant followed by growing degree days to tasseling and growing degree days to maturity. Growing degree days to the reproductive phase had the highest negative direct effect on grain yield. Viola *et al.* (2003) revealed that early silking and harvesting of fresh cobs, greater plant height, cob length, cob weight, cob height and number of cobs per plant and lesser cob girth directly contributed to increased cob yield.

Singh *et al.* (2003) observed that ear leaf area had the highest positive direct effect on green fodder yield per plant at genotypic and phenotypic levels followed by dry matter yield per plant, ear length and days to 50 per cent silking. Ear length had the maximum direct effect on grain yield followed by 500-kernel weight and ear leaf area. Number of leaves per plant, leaf: stem ratio and girth of basal internodes had also highly positive direct effect on grain yield per plant.

Srivas and Singh (2004) observed that dry fodder yield per plant, a dependent trait was significantly and positively associated with green fodder yield and its contributing traits such as plant height, days to 50 per cent silking, number of leaves per plant, stem girth, leaf blade length, leaf width and sheath length.

Kumar and Singh (2004) reported that cob length had maximum positive direct effect on grain yield at genotypic and phenotypic levels, respectively. Path analysis revealed that six characters had positive contribution to grain yield via number of other characters both at genotypic and phenotypic levels. Whereas, days to 50% tasseling and days to maturity had maximum negative effect on grain yield.

Bao Heping *et al.* (2004) reported that maize yield was mainly influenced by ear length, followed by number of kernels per row, ear width, number of rows per ear, growth period and 1000-seed weight. Kernel percentage per ear and number of pointless ears had minimum effect on maize yield.

Rafique *et al.* (2004) reported that grain yield was positively and significantly associated with all parameters studied. Number of kernels per row was positively correlated with grain yield followed by plant height, ear height, ear length and its diameter

Srivas and Singh (2004) observed that characters such as plant height, days to 50 per cent silking, stem girth, leaf length, leaf width and number of leaves per plant had positive direct effect on dry fodder yield at phenotypic levels. Patel *et al.* (2005) reported that dry matter yield per plant, number of leaves per plant, days to 50 per cent silking and plant height had positive direct effects on green fodder yield. Shelake *et al.* (2005) noticed that grain yield was positively and highly correlated with number of grains per cob, biological yield per plant, harvest index, 100-grain weight, cob length, number of grain rows per cob and cob girth. The number of days to 50 per cent tasseling, number of days to 50

per cent silking and harvest index showed higher genotypic direct effect. Biological yield per plant had the highest negative genotypic direct effect on grain yield. Ei-Shouny *et al.* (2005) showed that grain yield per plant correlated positively and significantly with ear diameter, ear length, number of kernels per row, 100-kernel weight, number of rows per ear, ear height, plant height and days to silking. Under normal planting date and with number of kernels per row, ear diameter, 100-kernel weight, ear length, number of rows per ear, ear height and days to silking under late planting date.

Sumathi *et al.* (2005) genotypic correlation studies indicated that ear weight, number of rows per ear, number of kernels/row, and total number of kernels/ear were positively associated with grain yield. Path coefficient analysis revealed that number of kernels per row showed high direct effect on grain yield followed by 100- seed weight, number of rows per ear and total number of kernels per plant.

Kumar *et al.* (2006) observed that days to 50% tasseling, anthesis silking interval, ear height and 100-seed weight had highest direct effect on grain yield. The days to 50 % silking exhibited negative direct effect on grain yield.

Harjinder *et al.* (2006) reported significant positive correlations for grain yield with days to 75 % husk, plant height, ear height, and number of ears.

Tan Heping *et al.* (2006) noticed that grain yield was significantly correlated with plant height, ear diameter, ear length, rare ear length, 100-kernel weight and grain production rate. Grain yield was most highly correlated with ear diameter, followed by 100-kernel weight, plant height, ear length and grain production rate. Wang Dachun (2006) reported that kernel weight per ear mainly affected by ear length and ear diameter and the ear length with bearing kernel played an important role on kernel weight per ear in high yielding combinations.

Wali *et al.* (2006) observed that yield was positively associated with plant height, ear length, ear circumference, number of kernels per row, fodder yield per plot and 100-grain weight, but was negatively correlated with number of days to 50 per cent silking at the phenotypic and genetic levels. The grain yield per plant was positively associated with plant height, ear length, ear circumference, number of kernels per row, fodder yield per plot and 100-grain weight at the phenotypic and genetic levels. Abirami *et al.* (2007) indicated that grain yield showed positive association with oil content and protein content. Path analysis showed that the weight of the cob contributed to the maximum direct effect to grain yield. It implied that selection for weight of the cob will be highly effective for the improvement of grain yield.

Bhoite *et al.* (2007) reported that dry matter and crude protein yields showed positive and significant correlation with green forage yield and had positive direct influence on their correlation with green forage yield.

Sofi and Rather (2007) reported that the genotypic correlation coefficient revealed that ear diameter, 100-seed weight, ear length, number of kernel rows per ear and number of kernels per row showed the greatest correlation with grain yield. Path analysis indicated that 100-seed weight had greatest direct effect on grain yield, followed by number of kernels per row, number of kernel rows per ear, ear length and ear diameter.

Xie Zhen Jiang *et al.* (2007) showed that kernels per plant was arranged for the top position among the many agronomic traits that contributed to the yield enhancement of a single plant and was followed by kernels per row, 1000-kernel weight and leaf orientation value.

Akbar *et al.* (2008) noticed that plant height had highly significant genotypic and phenotypic association with cob height and days to 50% tasseling with days to 50% silking. All traits had significant genotypic association but not

significant phenotypic association with grain yield. They showed that all traits exerted positive direct effect on grain yield per plant except days to 50% silking.

Bello *et al.* (2010) reported that positive and phenotypic and genotypic correlation coefficients had found for days to 50% tasseling with plant and ear height, and grain yield with plant height, number of grains/ear and ear weight. They also reported that days to 50% silking, ear weight and number of grains/ear had the highest direct effect on grain yield at genotypic level. Ferdous *et al.* (2010) reported that grain yield per plant indicated that significant and positive correlation with days to maturity grains/spike, 100-grain weight and harvest index in wheat.

Nastasic *et al.* (2010) reported that grain yield was positively and significantly genotypic correlation coefficients with kernel row number, ear length, kernel depth and 1000-kernel weight. They also reported that the direct effects, obtained in path coefficient analysis, in both studied population (S1, HS) indicated that grain yield at most depended upon 1000-kernel weight.

Rafiq *et al.* (2010) reported significant correlation of grain yield with ear diameter, 100-grain weight, ear length, rows per ear and grains per row in maize. They also reported that the highest direct effect on grain yield was exhibited by 100-seed weight followed by grains per row, grain rows per ear, ear length and ear diameter. Sreckov *et al.* (2010) observed that grain yield had significant positive correlation coefficients through ear height and length. They showed that population NSU1×568/11 had high significant, undesirable direct influence on grain yield and ear height.

Wannows *et al.* (2010) reported that grain yield was positively and significantly correlated with number of kernels per row, ear length, and leaf area index. They also reported that each of leaf area index, ear diameter and

physiological maturity had high positive direct effects on grain yield at the phenotypic level. Path analysis revealed that three characters had positive contribution to grain yield via number of other characters at phenotypic level.

SELECTION INDEX

Different selection indices were formulated using different combinations of yield and yield contributing characters and their expected genetic gains were estimated. The development of improved varieties with high yield potential can be seen as a possibility to increase production. Such varieties with qualitative and/or quantitative superior traits over previously recommended varieties are developed by genetic improvement, which represents one of the most successful modern technologies in agriculture, and accounts for approximately 50 % of the yield increments of most crops suggested by Fehr (1987).

To obtain genetic gains in different traits there are some methodologies of simultaneous selection (Cruz and Carneiro, 2003). Of these, the selection index proposed by Smith (1936) and Hazel (1943) has been well-accepted in maize improvement programs. This index associates the information of different traits of agronomic interest, based on economic weights, genotypic and phenotypic variances of each trait and the respective co-variances. Kumar and Kumar (2000) suggested that selection based on plant height with greater ear weight, number of seeds rows per ear and number of seeds per ear was desirable for grain yield.

Bergale *et al.* (2002) suggested that the number of spikes/plant, grains/spike and harvest index must be given preference in selection along with optimum plant height and days to flowering to selection the superior wheat genotypes. The demand for food is on the rise due to the growth of the human population. The global maize stocks that have been shrinking uninterruptedly over the last 5 years already reflect the increased demand reported by Dias (2005).

Shiv *et al.* (2008) reported that number of tillers/plant, numbers of spikelets/ear, number of grains/ear, grain weight/ear; 100-grain weight and biological yield could form effective selection indices for selection of high yielding genotypes of wheat.

Ferdous *et al.* (2010) reported that selection indices were constructed through the discriminate functions using eight respective characters. From that result, the highest relative efficiency was observed with the selection index based on three characters; plant height, grains/spike and grain yield/plant in spring wheat.

GENETIC DIVERGENCE

Wide range of variation was observed in cluster mean performance for most of the characters studied. All the genotypes were grouped into 5-clusters, indicating the presence of diversity for different characters. Williams and Hallaver (2000) reported that the cluster II (82) had the highest number of genotypes followed by cluster III (36) and cluster IV (19). The clusters IX and X were mono-genotypic reported by Williams and Hallaver (2000).

Yin ZhiTong *et al.* (2004) studied cluster analysis for various plant traits (including plant height, ear height, tassel length, stem diameter, ear length, ear diameter, number of rows, number of grains per row, 100-grain weight, yield per plant, dried ear weight and maturity period) classified some 110 maize inbreds into 5 groups. The genetic diversity among the inbred groups was greater than that within the same group, and heterosis among the groups was greater than that within the same group. To breed outstanding crosses, the parents should be selected from the various groups.

Singh *et al.* (2005) estimated D^2 analysis using 23 genotypes of maize in an experiment conducted in Karnal, Haryana, India, during kharif 1998. Observations were recorded for 50 per cent tasselling, 50 per cent silking, plant height, cob height, days to maturity, cob girth, cob length, number of rows per

cob, number of grains per row, 100-grain weight and grain yield per plant. The genotypes fell into 6 clusters. The inter-cluster distances were higher than intra-cluster distances, suggesting wide genetic diversity among the genotypes of different groups. The inter-cluster D^2 values indicated the maximum distance between clusters III and VI and the lowest distance between clusters I and IV. The cluster means were higher for 50% tasselling, 50% silking, plant height, cob height, cob length, number of grains per row and 100-grain weight in cluster IV; for cob girth, days to maturity and number of rows per cob in cluster II; and for grain yield per plant in cluster III followed by cluster II. The genotypes of these clusters would offer a good scope for the improvement of this crop through natural selection and hybridization. The genotypes included in the diverse clusters can be used as promising parents for hybridization to obtain high heterotic response and thus better segregates in maize. Based on genetic divergence and mean performance of yield and other characters, genotypes Vijay composite, NC-300, K-614, K-679, K-771, K-801, K-808, K-621 and CML-326 were selected.

Yuai *et al.* (2006) studied 24 varieties introduced from the Crop Institute, Chinese Academy of Agricultural Sciences to Hohhot, Nei Menggu [Nei Mongol], China and reported that cumulative contribution percentage of 7 principal components (morphology and yield factor, growth duration factor, rows/ear factor, low yield factor, oil content factor, protein content factor and ear length factor) to variation reached 83.149 per cent. Based on the analysis for each principal component vector, the introduced 24 varieties were grouped into 6 clusters.

More *et al.* (2006) reported that 45 diverse genotypes of forage maize for genetic diversity and identify the suitable genotypes for hybridization programmes based on clustering pattern. The genotypes were grouped into 7 clusters using Mahalanobis D^2 statistics. Cluster II was the largest with 25 genotypes followed by cluster III with 11 genotypes and cluster I with 5

genotypes. The clusters IV, V, VI and VII were mono-genotypic. The maximum inter-cluster distance was observed between clusters I and VI followed by distance between clusters I and IV and clusters I and V. Clusters V and VI exhibited the minimum inter-cluster distance.

Chen FaBo *et al.* (2007) reported that 186 maize hybrids could be classified into ten clusters, with 88.2 per cent of the hybrids included in Cluster 4, Cluster 8 and Cluster 10. The analysis of pedigree sources of 51 hybrids showed that 36 hybrids had close genetic relationships with the hybrids of Pioneer Company developed in late 1980s and early 1990s in the United States, such as "Y78599", "Y7865", "and Y78698", accounting for 70.58 per cent. Meanwhile, 13 hybrids had close genetic relationship with "Y78599", accounting for 8.66 per cent. The cluster analysis showed that 88.2 per cent of the 51 hybrids were in Cluster-4, Cluster-8, and Cluster-10. It was indicated that the similarity was high and the genetic diversity was narrow among the 186 hybrids. It is necessary to broaden the genetic basis of breeding germplasm in maize.

Ivy *et al* (2007) and Hoque *et al* (2008) reported that 24 maize inbred lines were grouped into 4 different clusters by using clustering techniques. The maximum inter-cluster distance was observed between clusters I and III and the lowest in II and IV. The highest mean values for kernel yield/plant, 1000-kernel weight, number of kernels per row and ear were observed in the same cluster III.

Azad *et al.* (2012) revealed that 30 maize inbred lines were grouped into 6 different clusters, based on medium to high inter-cluster distances, 6 lines were selected for hybrid program. Cluster VI showed the highest mean values for kernel yield and all the yield contributing characters except days to 50% tasseling and 50% silking. Days to maturity and ear diameter showed maximum contribution towards total divergence among different characters. These characters should be given importance, for selecting diverse parents for breeding programme.

DIALLEL AND COMBINING ABILITY

The concept of combining ability was originally evolved through the work of Davis (1927) who suggested that use of inbred cross to test the combining ability of inbreeds in maize. It may be defined as the ability of a strain to produce superior progeny upon hybridization with other strains. Combining ability provides information about the nature and magnitude of gene action controlling various quantitative characters. General combining ability (GCA) is the average performance of a line in hybrid combination and specific combining ability (SCA) is the deviation of crosses on the basis of average performance of the lines involved.

Diallel analysis is used to estimate GCA and SCA effects and their implications in breeding (Griffing, 1956; Gardner and Eberhart, 1966; and Baker, 1984). Griffing (1956) proposed an analysis for diallel mating systems that estimate the general and specific combining abilities of lines and hybrids. Combining ability analysis is important in identifying the best parents or parental combinations for a hybridization program. General combining ability is associated to additive genetic effects while specific combining ability is associated to non-additive genetic effects (Falconer and Mackay, 1996). Combining ability is an important aspect of hybrid breeding program. The proper identification of the genetically superior parents is dependent on the information obtained from the analysis of the combining ability.

The concept of combining ability was put forward by Sprague and Tatum (1942). According to them, general combining ability is the average performance of a strain in series of cross combinations estimated from the performance of F₁ is from the crosses, whereas specific combining ability is used to designate those cases in which certain combinations do relatively better or worse than would be expected as the basis of average performance of lines involved. The general combining ability is associated with genes which are additive in effects and specific combining ability is attributed primarily to

deviation from the additive scheme caused by dominance and epistasis (Rojas and Sprague, 1952).

Griffing (1956) has shown relationship between various heritable variance components and GCA and SCA variances. Thus GCA variance is due to additive variation and additive \times additive interaction variance, while SCA variance is due to dominance variance, additive \times additive variance, additive variance is due to dominance variance, additive \times additive variance, additive \times dominance variance components. Estimates of the variances due to GCA and SCA provide an appropriate diagnosis of the predominant role of additive or non-additive variance. Among the different biometrical methods employed to study combining ability, line \times tester is the most widely used method.

Allard (1960) reported that the combining ability analysis is highly useful technique for the plant breeder which provides indication of the genetic behavior of the parental material and is therefore desirable to select the parents for hybridization on the basis of their combining ability. Ratio of additive and non-additive gene action is to be considered in order to decide the predominance of the kind of genetic variation for a given character. If the ratio of additive to non-additive gene action is more than unity, indicates the major role of additive variance in controlling the expression of a character, whereas less than unity indicates the importance of non-additive variance (Gardner, 1963).

Muthiah (1989) reported that the proportion of GCA variance was higher than the SCA variance showing preponderance of additive genetic effects for all the characters studied. Crossa (1990) noted high general combining ability effects for high grain yield.

Results of Crossa *et al.* (1990) suggested that both additive and non-additive effects are important in controlling the expression of grain yield and days to silk; however, non-additive effects are more important in controlling grain

yield than in determining days to silk in CIMMYT's tropical late yellow maize germplasm.

Pal and Prodhan (1994) have also showed a greater influence of additive component of gene action in the expression of maturity. However, equal importance of both additive and non-additive gene action for days to maturity has been reported by Roy *et al.* (1998). Preponderance of additive genetic effects in the inheritance of ear girth has been reported by Das and Islam (1994), Pal and Prodhan (1994). On the other hand, specific combining ability is found to be very important for ear diameter (El-Hosary *et al.*, 1994 and Singh and Singh, 1998). More importance of additive gene action for days to maturity is to be found in 15 F₁ hybrids and their parents (Zelleke, 2000).

Pal and Prodhan (1994) have also showed a greater influence of additive component of gene action in the expression of maturity. However, equal importance of both additive and non-additive gene action for days to maturity has been reported by Roy *et al.* (1998).

Satyanarayana and Saikumar (1995) recorded low genotypic coefficient of variance combined with low to medium heritability and low genetic advances for grain yield.

But According to Altinbas (1995), GCA and SCA variances for grain yield per plant and other yield components indicated that screening parental lines and crosses based on combining ability effects for 100-grain weight and ear length should be effective. In case of other agronomic characters, genotypic coefficient of variance estimates were high combined with high heritability and genetic advance indicating the inheritance of additive gene action controlling these traits.

Dass *et al.* (1997) reported that non-additive gene action played major role in the inheritance of grain yield and majority of ear traits.

Joshi *et al.* (1998) observed both additive and non-additive gene effects in their early maturing inbred materials. However, the ratio of additive/non-additive

genetic variance revealed that there was preponderance of non-additive gene action in the expression grain yield/plant, protein and starch content, while for oil content and 100-grain weight there was preponderance of additive gene action.

Dutu (1998) observed that plant height was controlled by additive and non-additive gene actions and cytoplasmic inheritance, whereas number of leaves per plant was controlled by additive gene effects only.

Lou-Xiang Yang (1998) concluded that most plant and ear characters were improved with additive and dominance effects of the female parents. GCA variance is found to have significant for ear girth (Mathur *et al.*, 1998). General combining ability variance (Tulu and Ramachandrappa, 1998; Beck *et al.*, 1990) and both general and specific combining ability variances (Spaner *et al.*, 1996; Dahlan *et al.*, 1997; San-Vicente *et al.*, 1998; Lemos *et al.*, 1999; Talleci and Kochaksaraei, 1999 and Alam, 2009) are significant for plant height. Both additive and non-additive effects are to be found in genetically control of plant height reported by Choukan (1999). But additive gene effect is more important for plant height observed by (Crossa *et al.*, 1990; Mahajan and Khehra, 1991; Odongo and Bockholt, 1995; Paul and Debnath, 1999 and Zelleke, 2000). On the other hand, Suneetha *et al.* (2000) found preponderance of non-additive gene action for plant height. Both GCA and SCA effects are significant for ear height reported by Beck *et al.* (1990) and Talleci and Kochaksaraei (1999).

Additive effects are found in controlling ear height shown by Tulu and Ramachandrappa (1998), Choukan (1999) and Lemos *et al.* (1999). On the other hand, additive gene action is found more important than non-additive for ear height reported by Mahajan and Khehra (1991), Altinbas (1995), Odongo and Bockholt (1995) and Paul and Debnath (1999). Contrary to those, Dehghanpour *et al.* (1996) and Singh and Singh (1998) found more importance of non-additive effects in the expression of ear height. Significant GCA variance for ear length has been reported by Alike (1994), Spaner *et al.* (1996)

and Mathur *et al.* (1998). But Das and Islam (1994) reported equal importance of additive and non-additive variances for ear length. On the other hand, Zelleke (2000) observed more importance of additive gene action in controlling ear length and identified A1-175 x A1-178 as the best specific combiner. On the contrary, Pal and Prodhan (1994) showed more importance of non-additive gene effects in controlling of ear length. Similarly, Singh and Singh (1998) reported more importance of SCA for ear length.

Ramech *et al.* (2000) observed greater ratios of GCA to SCA mean squares for all traits except for number of seed rows per ear, indicating the importance of non-additive gene effects in their genetic control.

Rosa *et al.* (2000) obtained highest SCA values in 13 x 13 diallel crosses, viz., AS-910 x AS-4450 and PP-9538 x AS-948.

Desai and Singh (2001) reported significant difference in gca and sca effects for plant height, ear height and number of leaves per plant.

Kara (2001) observed significant gca effects for all the traits and significant sca effects for ear circumference, ear height and grain yield per unit area.

Konak *et al.* (2001) obtained non-additive gene effects for ear length and number of kernel rows per ear and additive gene effect for yield, 1000-kernel weight, plant height, ear height and days to silking.

Shabir and Saleem (2002) performed diallel analysis of six elite lines of maize and reported that all the characters being studied were under the control of over-dominance type of gene action, except protein percentage which showed additive type of gene action.

Ahmad and Saleem (2003) observed that both additive and non-additive gene effects played an important role in the genetic control of all the traits. The estimates of mean of squares due to general combining ability were significant for all the traits except growing degree days in both F₁ and F₂ generations. Mean squares due to specific combining ability were significant for all the traits in both the generations.

Abdel-Sattar (2003) observed that value of GCA and SCA were increased from 53 to 55 self generations. The ratios of GCA/SCA through all self generations showed greater role of dominance variance than that of additive variance. Lines contributed much more than the testers to the total genetic variation.

Srivastava and Singh (2004) reported that the specific combining ability variance was greater than general combining ability variance indicating the importance of non-additive gene effects for ear diameter, ear length, number of rows per ear and grain yield.

Ming *et al.* (2004) revealed that the inbreds had high combining ability for grain yield of ten quality protein maize (QPM) lines and showed high general combining ability (GCA) and it is possible to get high yielding crosses by using them as parents. The results from the yields of F₁ crosses suggest that lines with high GCA and specific combining ability (SCA) should be selected as parents.

Koinuma *et al.* (2004) noticed that new inbred line H049 shows high combining ability with dent inbred lines.

Reddy *et al.* (2004) reported that no association was found between mean *per se* and all other estimates. They noticed that general combining ability failed to exhibit closer association in grain yield per plant and ear length.

Malik *et al.* (2004) reported that GCA effects were highly significant for all the traits under study, but SCA effects were less significant in certain cases suggesting predominance of additive genes. High *gca* effects for grain yield were observed in the temperate material, i.e., QPM-1 (0.168), QPM-3 (0.169) and QPM-5 (0.485), while *sca* effects were remarkable for hybrids QPM-3 NCML-1078 (0.890), NCML-NCML-1084 (0.878) and NCML-1082 NCML-1083 (0.831).

Uddin *et al.* (2006) studied that significant differences for GCA and SCA indicated the presence of additive as well as non-additive gene effects were more prominent for all the characters studied except grain yield/plant.

Ojo *et al.* (2007) reported that GCA mean squares were however highly significant and higher than SCA mean squares for grain yield, indicating a predominance of additive gene action for grain yield.

Aliu *et al.* (2008) reported that both GCA and SCA effects are significant for ear weight, indicating that both additive and non-additive genetic actions were important combining of hybrids from the diallel crosses.

Uddin *et al.* (2008) reported that GCA and SCA variance for yield/plant, number of kernels/row and 100-kernel weight was observed significant, which indicated importance of additive type of gene action for these characters.

Alam *et al.* (2008) reported that almost equal role of additive and non-additive gene action was observed for days to maturity. Additive genetic variance was preponderant for grains per ear and 1000-grain weight and non-additive gene action was involved in plant height, ear height, days to silking and days to maturity.

Ahmad *et al.* (2011) reported that the relative magnitude of GCA and SCA variances indicated that additive gene effects were more prominent for days to heading and grain weight.

Singh *et al.* (2012) revealed that estimates of SCA variances were higher than GCA variances for number of kernels per row, cob height and 50% silking under study, indicating predominance of non-additive gene action of these traits. The parents HUZQPM 3-2, HUZQPM 6-2 and HUZQPM 5 were identified as good combiners for yield and its related traits.

Estakhr and Haidari (2012) reported that significant for GCA and SCA mean squares for plant height, ear height, ear diameter, ear length, grain number per ear, grain moisture and cob percentage which is an indication of the importance of both additive and non-additive genetic effects.

GENE ACTION AND THEIR PROPORTIONS

The choice of a suitable breeding method depends to a large extent on the nature of gene action involved. Fisher (1918) and Wright (1935) defined three types of variances as additive genetic variance, variance due to dominance deviations and epistatic variance resulting from the interaction of non-allelic genes.

Hayman and Mather (1955) further showed that epistatic variance can be partitioned into genetic interactions of the additive x additive, additive x dominance and dominance x dominance types and higher order interactions.

The selection of suitable parents is one of the most important steps in hybridization program. Selection of the parents on the basis of phenotypic performance alone is not sound since phenotypical superior lines may yield poor recombination in the segregating generations. It is, therefore, essential that parents should be chosen on the basis of their genetic values. There are several techniques for the evaluation of varieties or strains in terms of their genetic makeup. Of these, diallel analysis technique (Hayman 1954a, b) is the popular method to study components of variation. It was developed by Jinks (1954), Hayman (1954a, b) and Jinks and Hayman (1957) using Mather's concept of D, H components of variation. While a negative F value indicates an excess of recessive alleles in the parents, a positive value shows more dominant alleles than recessive alleles of each gene are distributed equally among the parents, the F value will be equal to zero reported by Allard (1962). Over dominance as well as predominant role of non-additive genetic variance in the inheritance of kernel yield of maize was also reported by Gardner and Lonquist (1961), Gamble (1962a), Gardner (1963), Nawar *et al.* (1980, 1981), Genova (1984), Shahi and Singh (1985) and Genov (1987). Regarding 1000-kernel weight non-allelic interaction with over dominance was found by Gamble (1962b) and Debnath and Sarkar (1990b). As an indicator of the relative frequency of dominant and recessive alleles in the parents, the F value was found to be

positive but non-significant for grain yield, which means either that no allele's exhibit dominant or else that the dominant and recessive alleles are distributed equally among the parents observed by Verhalen and Murry(1967).

Mather and Jinks (1971) concluded that Hayman's analysis was the most useful to determine the significance of principal genetic components. The components D, H₁ were significant for ear length, ear diameter and kernel rows per ear. The ratio $(H_1/D)^{1/2}$ was greater than one for kernel yield, kernel rows per ear and 1000-kernel weight indicating over dominance in the inheritance of these characters. All the characters except ear diameter exhibited presence of non-allelic interaction in their inheritance. Over dominance as well as importance of non-additive gene action in the inheritance of grain yield was observed by Gamble (1962a), Darrah and Hallauer (1972) and Genov (1987). On the other hand, Lonquist and Castro (1967) and Murthy (1978) reported partial dominance as well as predominant role of additive genetic variance for this trait. Epistasis was also observed in grain yield by Gamble (1962a) and Darrah and Hallauer (1972). Partial dominance as well as importance of additive gene effects in the inheritance of kernel rows per ear was reported by Singh (1979). Over dominance for predominant non-additive genetic variance was observed by Nawar *et al.* (1980) for kernel rows per ear and by Gamble (1962b) for kernel weight.

Debnath and Sarker (1989) reported complete dominance in the inheritance of ear diameter as the ratio $(H_1/D)^{1/2}$ was very close to unity. Positive but insignificant values of F for all characters except ear length and ear diameter indicated almost symmetrical gene distribution with a small excess of dominant alleles in the parents. The ratio (h^2/H_2) suggested that the kernel yield be under control of highest number of genes or gene group. However, kernel weight was controlled by the lowest number of genes. They also reported that all characters were under polygene control.

Debnath and Sarker (1990b) undertook an experiment to characterize the nature and magnitude of genetic variability for grain yield and some of its components in nine maize inbreds. The results revealed evidence for existence of enough genetic variability in the parental materials, which is essential for the improvement of a crop. Over dominance as well as non-additive component of genetic variance was observed to be important for all traits except kernel rows per ear. Partial dominance as well as additive gene effect was found to be predominant in the inheritance of kernel rows per ear. Debnath and Sarker (1990b) observed epistasis along with over dominance in the inheritance of ear length. For ear breadth they reported absence of non-allelic interaction in the inheritance. They also reported over dominance for this trait.

Kara (2001) and Alam (2009) estimated that a non-additive gene effect was involved in maize grain yield. The estimated heritability degree of yield (narrow sense; 0.236) is consistency with other researcher's results by Dehghanpour *et al.* (1996), Singh *et al.* (1998), Chaudhary *et al.*(2000), Kara *et al.*(2001) and Muhammad and Muhammad (2002).

Onay *et al.* (2004) reported the letter alternative may apply since the variances for H_1 and H_2 were significantly different from zero. It may thus be concluded that the dominant and recessive alleles of the related genes are distributed equally among the parents. Since the mean dominance effect of the heterozygote locus (h^2) was significant, high heterotic effect values would be expected for grain yield among crosses. The parameters, E, an estimate of the environmental variation and D, the additive genetic variation, were not different from zero. The parameter D, which may also include a portion of the additive \times additive epistatic variances as well as additive genetic variance itself, was non-significant for grain yield. Dominance variance (H_1) and corrected dominance variance (H_2) were significantly different from zero. It may thus be concluded that grain yield is under the dominance effect. This result was also supported

by the GCA/SCA ratio (0.65). They also showed that over-dominance from the W_r - V_r graph for the inheritance of grain yield.

Ahmed *et al.* (2011) who found preponderance of recessive alleles of weight of spikes/plant in wheat genotypes. Adel and Ali (2013) had shown that dominant genes being to the origin for grain yield/plant in wheat.

HETEROSIS

Hybrid maize has made a significant contribution to increasing productivity during the course of twentieth century both in the developed as well as the developing world. Exploitation of heterosis in maize can be achieved by using progenitors of different kinds, which may be inbreds, non-inbreds and even a combination of both (Leon and Vasal, 2000). The superiority of variety crosses over the parental varieties was established by Beal (1980). He advocated commercial cultivation of inter-variety hybrids. The basis of inbred-hybrid concept resulted from systematic researches done by East (1908), Shull (1908, 1909) and Jones (1918). Various theories have been pronounced to explain and understand the phenomenon for heterosis.

Jinks (1955) suggested that the non-allelic interaction might be the cause of heterosis rather than the special relation between genes at the same locus Mather (1955) considered heterosis as an expression of genetic balance, which might vary, with the breeding behaviour of species. Jinks and Jones (1958) stated that heterosis was a complex genetically phenomenon depending upon the balance of additive action, dominance and interaction of homozygous / homozygous and homozygous/heterozygous components as well as on the distribution of the genes in parental lines. Williams (1959) suggested that dominance or partial dominance of the alleles for favorable expression of the component characters could explain heterosis. Appreciable percentage of heterosis (112, 90, 43, 93 and 111 to 128%) for grain yield in maize was also reported by Lonquist and Gardner (1961), Ruckij (1963), Akhtar and Sing

(1981) and Gerrish (1983) respectively. Heterosis has been exploited profitably in many cross-pollinated crops by crossing highly selected inbred lines (Mian, 1985). According to him heterosis in F_1 is the combined expression of genetically, cytoplasmic and physiological factors and might be attributed to stimulation resulting from the interaction of different heritable factors of the parents.

Bhalla *et al.* (1979) observed that in general, the crosses between genetically diverse varieties showing superior heterosis values for yield also showed increased hybrid vigour in respect of ear length and ear diameter, but not for number of kernel rows per ear. Hallauer and Miranda (1981) summarized 47 independent reports and found the mean high-parent heterosis for yield to be 8.2% from 1394 varied crosses involving 611 parent varieties.

Debnath (1984, 1987) reported 37.4 to 245.0% heterobeltiosis for kernel yield in maize. Saha and Mukherjee (1985) studied heterosis manifest for number of grains in a set of inter-varietal crosses of maize. The investigation indicated the possibility of maximising heterosis for number of grains by identifying parents possessing the highest level of heterotic potential for number of ovules and per cent of grain conversion. Debnath (1987) studied heterosis in maize using nine maize inbreds and their 36 F_1 'S and observed significant positive heterosis over mid and better parent. Among the component characters, highest percentages of heterosis were observed in number of kernels per row followed by ear length and 1000-kernel weight. Heterosis for ear diameter and kernel rows per ear was low. Seven crosses with highly significant desirable heterobeltiosis for grain yield and some of its attributes were selected for exploiting their heterotic performance. Debnath (1989) estimated 43.05 to 96.74% heterosis over better parent for kernel yield, 3.41 to 8.06% for days to silk and 6.62 to 36.98% for plant height in 18 hybrids from inbred lines. Misevic (1990) estimated 11.3 and 8.7% heterosis for grain yield and plant height, respectively.

Crossa *et al.* (1990) reported mid-parent heterosis ranging from 17.5% to 3.3% in tropical late-maturity yellow germplasm. High parent heterosis (9.6%) for grain yield among crosses was observed in CIMMYT's tropical early and intermediate maturity maize (Beck *et al.* 1990).

Han *et al.* (1991) conducted an experiment with CIMMYT inbred lines of maize and reported that low heterosis in the population crosses could be due mainly to insufficient genetic diversity between the two populations and great genetic variability within the populations and pools involved in their study.

Beck *et al.* (1991) also reported low estimate of high-parent heterosis (16% in U.S. and 9.9% in Mexican environment) in CIMMYT's subtropical and temperate intermediate-maturity maize germplasm, although in subtropical early-maturity germplasm moderate levels of heterosis (13%) was noticed by Vasal *et al.* (1992a). Ordas (1991) reported 32.7% mid-parent heterosis for yield in crosses between American and Spanish populations of maize.

Vasal *et al.* (1992b) reported that high x low yielding parent of tropical and subtropical germplasm exhibited the highest heterosis (23.7%). However they observed high-parent heterosis in crosses between tropical germplasms ranging from 12.7% to 3.1%. The magnitude of heterosis exhibited in any crop is extremely important in decision making process to initiate hybrid development efforts. Though optimum yield heterosis levels will differ for each crop, there is a consensus among most breeders that a heterosis level of at least 20% is desirable (Vasal, 2000).

Vasal *et al.* (1993a) reported 15.6% high-parent heterosis for grain yield in quality protein maize (QPM) populations. They stated that crosses between parents with divergent endosperm modifications resulted in higher heterosis for grain yield. Crosses between hard and soft endosperm parents were intermediate in their endosperm rating, indicating that polygenic system was involved in another study. Vasal *et al.* (1993b) reported that a cross combination involving QPM parent's population with white and yellow kernel

color showed 14.8% heterosis in Mexican environment and 19.7% in U.S. environment. They observed many high yielding crosses that involved parents with different kernel color.

Gomaa and Shaheen (1994) obtained heterotic effects for grain yield/plant of F1 hybrids ranging from 23.5 to 36.3% of the mid-parent and from 32.0 to 18.7% of the better parent.

Kim and Ajala (1996) reported that several factors could have influenced level of heterosis. They obtained highest yield in white x yellow cross. Relative distance between the two color groups might increase levels of heterosis; grain texture was another factor that might influence levels of heterosis. The advantage of dent x flint crosses over dent x dent or flint x flint was reported by Wellhausen (1978) and Kim *et al.* (1985).

Dass *et al.* (1997) conducted an experiment to identify bold seeded parental lines and to exploit them in the breeding program for developing high yielding hybrids/composite cultivars in maize. Combining ability analysis revealed that both additive and non-additive genetic variances were important in the expression of seed weight and yields in winter and summer seasons. Results on SCA effects indicated that most of the superior crosses were between high x low and high x medium parents and that involvement of one good general combiner was essential to get better specific combination. They suggested development of season specific hybrids.

Roy *et al.* (1998) obtained -16.42 to 71.82% heterobeltiosis for yield in crosses among six genetically diverse composite parents.

Koirala and Gurung (2002) observed that high parent heterosis for grain yield ranged from -17.8 to 23.9%.

Uddin *et al.* (2006) explained that the better performing four crosses (P₁xP₇, P₆xP₇, P₁xP₄ and P₄xP₅) can be utilized for developing high yielding hybrid varieties as well as for exploiting hybrid vigor. Except cross P₂xP₅, rest of the crosses showed significant positive heterobeltiosis both in plant and ear height.

Alam *et al.* (2008) studied that the highest % of heterosis for grain/ear over mid parent and better parent were observed by the cross $P_2 \times P_3$. Crosses $P_1 \times P_3$ and $P_1 \times P_5$ showed significant negative heterosis for days to maturity.

Uddin *et al.* (2008) reported that the highest significant positive heterosis (28.41%) for grain yield was observed in the cross IPB911-11 \times BM-7.

Amanullah *et al.* (2011) reported that 21 crosses had positive heterosis for grain yield/ha and ranged from +0.39% to 86%. The heterosis and heterobeltiosis for 1000-seed weight was 12.9% and 4.57%.

Singh *et al.* (2012) obtained highest heterosis in the crosses of HUZQPUM 3-2 \times HUZQPM 4-2 and HUZQPUM 1-1 \times HUZQPM 3-2 for grain yield and number of rows per ear.

Parihar *et al.* (2012) observed maximum economic heterosis in all the environments for grain yield per plant in the crosses $P_9 \times P_{12}$ and $P_4 \times P_{12}$.

MATERIALS AND METHODS

The details of materials used and methods followed in carrying out the present investigation are presented in this chapter.

EXPERIMENT I

3.1.1 MATERIALS

The experimental material consisted of 25 maize (*Zea mays* L.) inbred lines. They were IL1, IL2, IL3, IL4, IL5, IL6, IL7, IL8, IL9, IL10, IL11, IL12, IL13, IL14, IL15, IL16, IL17, IL18, IL19, IL20, IL21, IL22, IL23, IL24 and IL25. The maize inbred lines were received from Biometrical Genetics Lab, Department of Botany, University of Rajshahi, Bangladesh.

3.1.2 METHODS

The methods followed to conduct the experiments and analysis of data is described below.

Preparation of the Experimental Field

The experiment was carried out in the Botanical Research Garden of Rajshahi University during the Rabi crop season of 2008, 2009 and 2011. The experimental land was first opened on the month of November in every experimental year and the operations were done by power tiller and harrows. The land was again ploughed and cross-ploughed with a power tiller followed by laddering during the course of final land preparation. All crop residues and weeds were removed completely before layout of the field and sowing of the inbred seeds. The field was pulverized and leveled properly. As the experimental field was sufficiently moist, no irrigation was given before sowing of the seeds. The recommended practices were provided to raise a good crop. Irrigation, weeding and other intercultural operations were done as and when necessary.

Soil and Climatic Condition of the Experimental Field

The experimental field area was a medium high land. The texture of the soil was fertile and silty loam having pH 5.2-6.4. The topography of the field was medium high land above flood level. It was readily broken when pulverized. Well drained sandy loam and medium loam soils, rich in humus are most suitable for maize. The climate of the location is characterized by relatively low temperature and little rainfall during rabi or winter season (November to March) and high temperature and rainfall during kharif or summer season (April to October).

Experimental Layout and Size of the Experimental Field

Layout of the experimental field and 25 inbred lines were sown in a Randomized Block Design with three replications. The field comprised total area of 12×18 square meter having 3 replications. Size of each replication was 16.5 m × 5 m having 25 rows (lines). Each line contained 10 plants. The distance was 100 cm from row to row and 30 cm from plant to plant and in each row ten hills was maintained. In each hill, one plant was maintained. The inbred lines were randomly assigned in each line of replication plot.

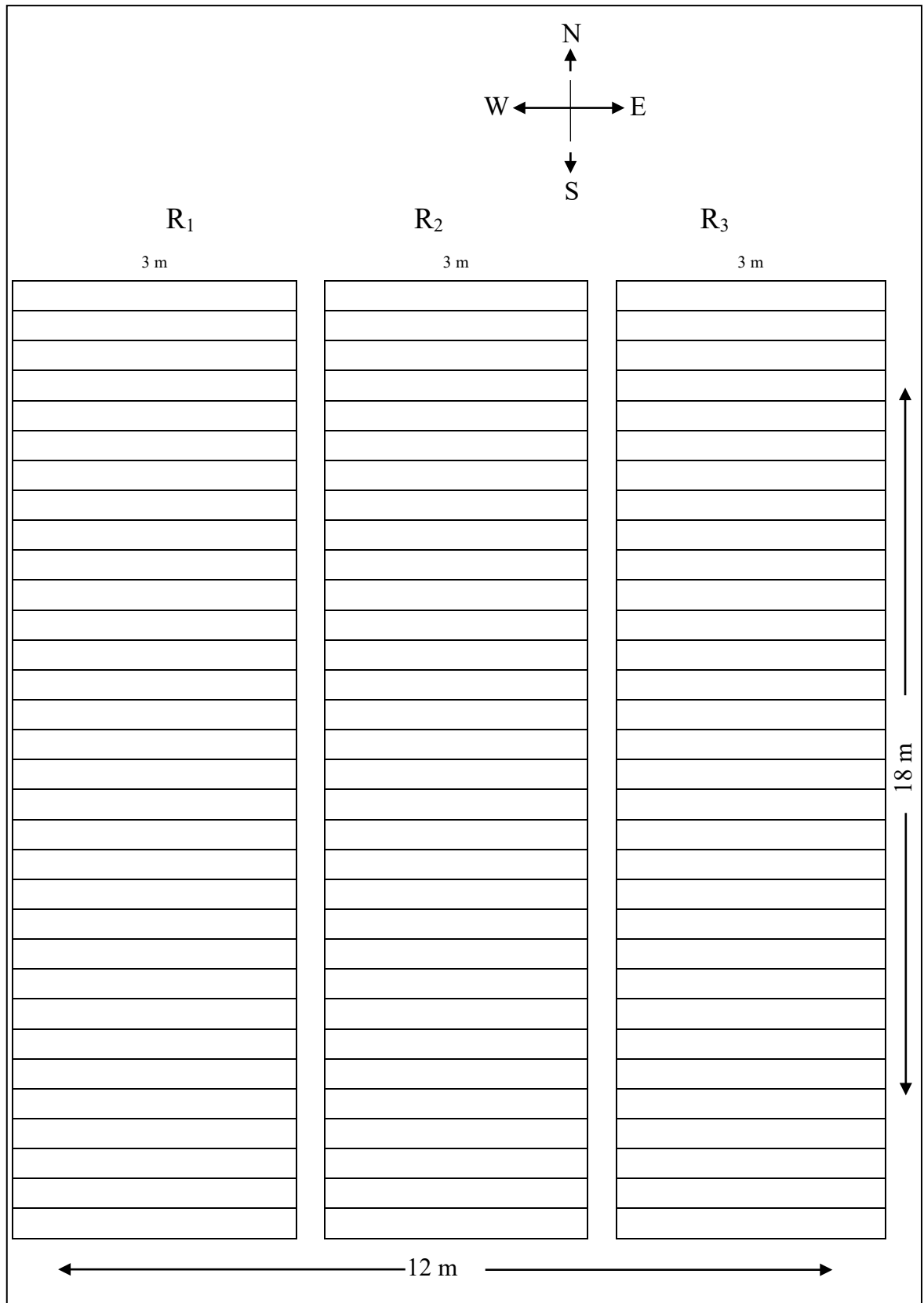

Figure 3.1.1 Design of the experimental field

Sowing of Maize Inbred Lines and Raising of Seedlings

Twenty-five maize inbred lines were randomly assigned to the inner 25 lines in each replication. Before sowing, inbreds were treated with vitavex-200 (0.3%). After sowing, inbred lines were covered with soil. The sowing date in three years was 24 November 2008, 26 November 2009 and 28 November 2010, respectively. When seedling emergence was completed 10 plants were kept in each row (line) of each replication.

Intercultural Operation and Disease Control

Weeding was done twice, one within 25-30 days after sowing and other within 40-45 days after sowing; the plants were 15-20 cm in height. Irrigation was done to the experimental plot as needed. The crops were almost free from diseases and insect pests. Only at the early stage of growth, seedlings were sprayed appropriated insecticide.

Collection of Data

Five plants were tagged randomly for recording observations for each entry for all the quantitative characters. Mean of five plants for each entry in each replication was worked out for each character at each replication and used for statistical analysis. Data on the following quantitative characters were recorded at appropriate stages of plant growth.

i). Days to tasseling

The number of days from sowing up to the day on which 50% of the plants showed tassel emergence was recorded as days to 50% tasseling.

ii). Days to silking

The number of days from sowing up to the day on which 50% of plants showed silk emergence was recorded as days to 50% silking.

iii). Days to maturity (DM)

Maturity time was recorded in days from the date of planting to the date of yellowish layer formation of grain of 50% population.

iv). Plant height (cm)

Height of the plant from ground level up to the base of fully opened flag leaf was recorded in centimeters as plant height when plants were mature.

v). Ear height (cm)

Height from ground level up to the base of the upper most bearing internode was recorded as ear height in centimeters.

Collection of Data on Harvesting and Cob Related Characters

The maize inbred lines were harvested at 90 days (5 March 2009, 9 March 2010 and 12 March 2011). When the color of leaf turned yellow and dropped off then plants of individual orientation as tagged previously were separately harvested. Harvested inbred lines were cured and slotted properly. Data on different quantitative characters were collected on individual plant basis from five plants randomly selected in each line of each replication. All the measurements were taken in CGS system. Cob related data were measured and recorded on the following characters:

vi). Cob length (cm)

Length of the ear was measured and recorded in centimeters at the time of harvest as its total length (from the base to the tip of the ear).

vii). Cob diameter (cm)

Cob diameter was measured and recorded in centimeters as the thickness of the ear i.e., at the middle of the ear.

viii). Number of kernel rows /cob

Number of kernel rows per cob was counted and recorded.

ix). Number of kernels /row

Number of kernels per row was counted and average was recorded as number of kernels per row.

x). Number of kernels /cob (number of grains/ear)

The total number of kernels per cob was counted and recorded.

xi). Grain yield/plant (g)

Grain yield per plant expressed in grams was recorded by weighing the grains obtained after shelling of cobs from individual plant.



Exp. I. Seedling stage of the maize inbreds



Exp.I. Maturity stage



Collected cob with husk



Collected cob of different inbreds



Exp.II Crossing block



Crossing block

Plate No. 1: Different stages of inbreds and crossing block



Collection of F₁ seed



Collection of F₁ seeds



Lay out of experiment II



Sowing period of F₁ seeds



F₁ plants



F₁ plants

Plate No. 2: F₁ seeds and F₁ plants

Techniques of Statistical Analysis of Data

Mean data of three years were analyzed in the first experiment. The collected data were analyzed following the biometrical techniques of analysis as developed by Mather (1949) based on mathematical model of Fisher (1936).

Genotypic variance, phenotypic variance, genotypic coefficient of variation and phenotypic coefficient of variation were estimated as suggested by Singh and Chaudhary (1985).

Broad sense heritability was calculated as suggested by Johnson *et al.* (1955) and genetic advance was estimated using the formulae suggested by Johnson *et al.* (1955) and Hanson *et al.* (1956).

Genotypic and phenotypic covariances were estimated according to the formulae suggested by Singh and Chaudhary (1985).

Genotypic and phenotypic correlation coefficients were calculated using the formulae suggested by Miller *et al.* (1958).

Path coefficient analysis was done following the method as suggested by Dewey and Lu (1959). As per suggestion of Robinson *et al.* (1951) yield was also included as one of the independent characters.

The expected genetic advance from straight selection [GAS] and from the discriminant function [GAD] was first estimated and the expected gain from the discriminant function over straight selection was calculated for all the functions studied as follows: Expected gain (%) = $[(GAD/GAS)-1] \times 100$. Multivariate analysis was done based on Mahalanobis analysis, D²- statistics (Mahalanobis, 1936).

General combining ability (GCA) and specific combining ability (SCA) were estimated by following Model-1, Method of Griffing (1956). The mean squares for GCA and SCA were tested against error variance desired. Mean data were used to estimate heterosis over mid parent and better parent according to Rai (1979).

The techniques used for analysis of data are described under the following sub-heads:

(i) Mean

Data on individual plant basis were added together and then divided by the total number of observations and the mean was obtained as follows:

$$\text{Mean } (\bar{x}) = \frac{1}{n} \sum_{i=1}^n X_i$$

Where,

X = The individual reading was recorded on each plant

n = Number of observations

i = 1, 2, 3.....n

Σ = Summation

(ii) Standard deviation (SD)

Standard deviation is the average deviation of the individual observation from the mean. It was calculated as the square root of the variance as follows:

$$SD = \sqrt{\sigma^2}$$

Where,

SD = Standard deviation

σ^2 = Variance

(iii) Standard error of mean (SE)

If several samples are considered instead of taking one, it will be found that the standard deviations of the different samples also vary. This variation is measured by the standard error of mean, which was calculated as follows:

$$SE = \frac{SD}{\sqrt{n}}$$

Where,

SD = Standard deviation

SE = Standard error of mean

n = Total number of individual

(iv) Coefficient of variability in percentage

Coefficient of variability in percentage (CV %) was calculated according to the following formula:

$$CV\% = \frac{S}{\bar{x}} \times 100$$

Where,

CV% = Coefficient of variability in percentage

S = Standard deviation,

\bar{x} = Genotypic mean.

(v) Analysis of variance

Variance is a measure of dispersion of a population. So, the analysis of variance is done for testing the significant differences among the populations. Variance analysis for each of the characters was carried out separately on individual plant value of a row.

The variances due to different sources such as; line (L), replication(R), interaction of R × L and within error (E) of a population were calculated as per the following skeleton of analysis.

The variance due to different sources such as inbred line (IL), replication (R), interaction of (IL×R) and within error (E) of population were calculated as per the following skeleton of analysis:

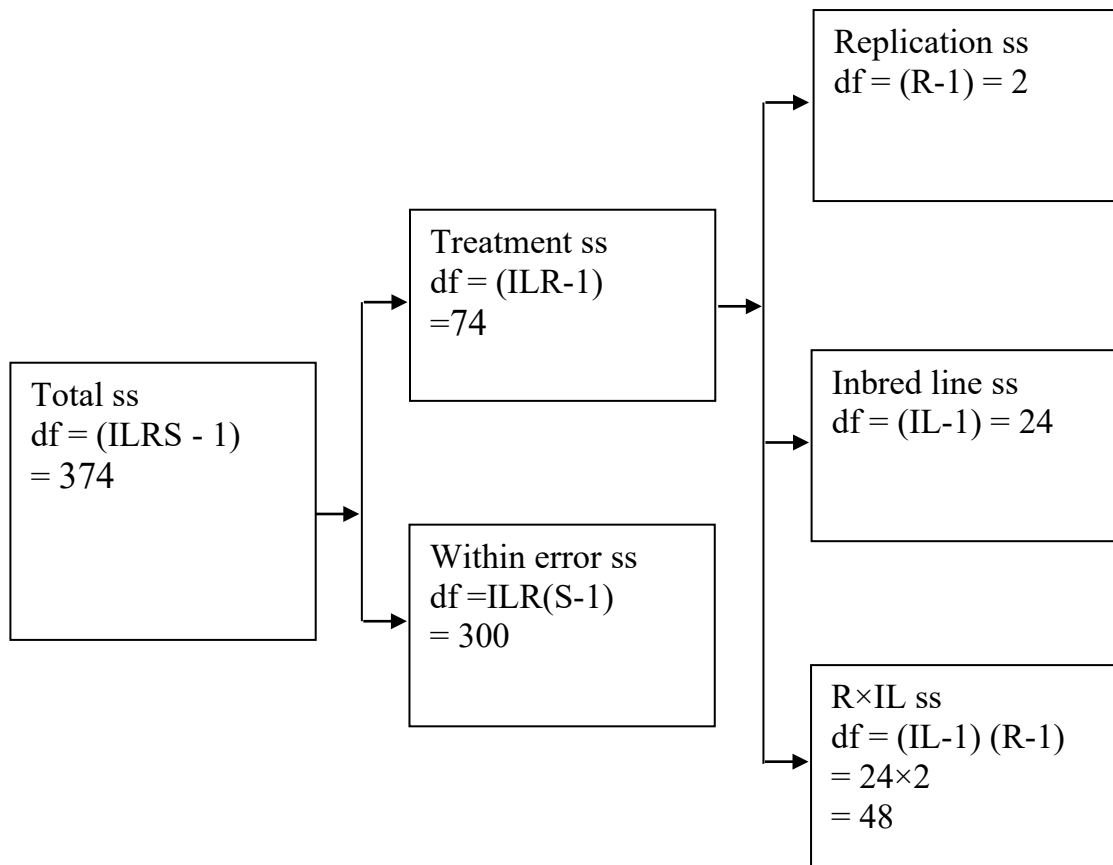

Where,

$$\text{Total ss} = \sum (\text{LRS})^2 - \text{CF}$$

$$\text{Treatment ss} = \frac{\sum_{ij} (\text{L}_i \text{R}_j)^2}{\text{S}} - \text{CF}$$

$$\text{Replication ss} = \frac{\sum_j \text{R}_j^2}{\text{SL}} - \text{CF}$$

$$\text{Line ss} = \frac{\sum_i \text{L}_i^2}{\text{SR}} - \text{CF}$$

$$(\text{L} \times \text{R}) \text{ ss} = \frac{\sum_{ij} (\text{L}_i \text{R}_j)^2}{\text{S}} - \text{CF} - \text{L}_{\text{ss}} - \text{R}_{\text{ss}}$$

$$\text{Error ss} = \text{Total ss} - \text{Treatment ss} - \text{Replication ss}$$

L_i = The value of i^{th} line,

R_j = The total of j^{th} replication

L_iR_j = The value of i^{th} line in j^{th} replication

S = The value of the s^{th} replication

CF = Correction factor = $(GT)^2 / N$

GT = Grand total,

N = Total number of observations = (SLR)

The analysis of variance of a mixed model was used, where line (L) was fixed and replication (R) effect is random.

The expectation of mean square (E.M.S) is derived as follows.

Table 3.1.2.1 Analysis of variance (ANOVA)

Source of variation	df	MS	EMS
Replication (R)	R-1	MS ₁	$\sigma_{we}^2 + S\sigma_R^2$
Inbred line(L)	L-1	MS ₂	$\sigma_{we}^2 + S\sigma_{LR}^2 + RS\sigma_L^2$
R×L	(R-1) (L-1)	MS ₃	$\sigma_{we}^2 + S\sigma_{LR}^2$
Within error	RL(s-1)	MS ₄	σ_{we}^2

Where,

L, R, S designated for line (genotype), replication and sib respectively.

MS₁= Represents mean square of replication.

MS₂= Represents mean square of line.

MS₃= Represents mean square of R×L

MS₄= Represents mean square of within error and

$S\sigma_R^2$ = Variance due to replication

$RS\sigma_L^2$ = Variance due to line

$S\sigma_{LR}^2$ = Variance due to L×R

σ_{we}^2 = Variance due to within error

*, ** and *** denoted 1%, 5% and 0.1% level, respectively.

(vi) Components of variation

The components of variation were phenotypic (σ^2_p), genotypic (σ^2_g), Replication (σ^2_R), interaction (σ^2_{LR}) and error (σ^2_w) variances. These were measured as follows:

$$\begin{aligned}\text{Step-I: } \sigma^2_R &= (MS_1 - MS_4)/sl \\ \sigma^2_L &= (MS_2 - MS_3)/rs \\ \sigma^2_{LR} &= (MS_3 - MS_4)/s \\ \sigma^2_{we} &= MS_4\end{aligned}$$

Step-I I:

- i) Phenotypic variance (σ^2_p) = $\sigma^2_L + \sigma^2_{LR} + \sigma^2_{we}$
- (ii) Line variance (σ^2_g) = σ^2_L
- (iii) Replication variance = σ^2_R
- (iv) Line \times Replication variance = σ^2_{LR}
- (v) Error variance = σ^2_{we}

vii) Estimation of genotypic and phenotypic coefficient of variation

Genotypic coefficient of variation (GCV) and phenotypic coefficient of variation (PCV) were calculated as per Singh and Chaudhary (1985) by the following formulae.

a) Phenotypic coefficient of variability

$$PCV = \sqrt{\frac{\sigma^2_p}{\bar{x}}} \times 100$$

b) Genotypic (Line) coefficient of variability

$$GCV = \sqrt{\frac{\sigma^2_g}{\bar{x}}} \times 100$$

c) Genotype \times Replication coefficient of variability

$$G \times RCV = \sqrt{\frac{\sigma^2_{lr}}{\bar{x}}} \times 100$$

d) Error coefficient of variability

$$ECV = \sqrt{\frac{\sigma^2_e}{\bar{x}}} \times 100$$

Where,

$$\begin{aligned}\sigma^2_g &= \text{Genotypic variance} \\ \sigma^2_p &= \text{Phenotypic variance,} \\ \bar{x} &= \text{Population mean}\end{aligned}$$

(viii) Heritability (h^2_b)

Heritability (in broad sense) estimates was computed by dividing the genotypic variance with phenotypic variance and then multiplying by 100 as suggested by Warner (1952).

$$h^2_b (\%) = \frac{\sigma^2_g}{\sigma^2_p} \times 100$$

Where,

h^2_b = Heritability in broad sense

σ^2_g = Genotypic variance

σ^2_p = Phenotypic variance

(ix) Genetic advance (GA)

Genetic advance was calculated by the following formula as suggested by Allard (1960):

$$GA = K \cdot \sigma_p (\sigma^2_g / \sigma^2_p)$$

Where,

K = the selection differential in standard units for the present study it was 2.06 at 5% level of selection (Lush, 1949).

σ_p = Square root of the phenotypic variance

σ^2_p = Phenotypic variance

σ^2_g = Genotypic variance

(x) Genetic advance in percentage of mean (GA %)

Genetic advance in percentage of mean was calculated by the following formula given by Comstock and Robinson (1952):

$$GA \% = \frac{GA}{\bar{X}} \times 100$$

Where,

\bar{x} = Population mean

(xi) Analysis of covariance

For the purpose of correlation coefficients and path-coefficient, the analysis of both variance and covariance are required (Miller *et al.*, 1958). Therefore, covariance was calculated between all possible pairs of characters.

Mean value per replication per genotype of three years were arranged in combined table and analyses of covariance were done as per following formula:

$$\text{Cov.} = \frac{\sum_{i=1}^n X_i Y_i - \left(\sum_{i=1}^n X_i \right) \left(\sum_{i=1}^n Y_i \right) / n}{n-1}$$

Where,

Cov. = Covariance

$\sum_{i=1}^n X_i Y_i$ = Sum of X and Y

$\sum_{i=1}^n X_i$ = Grand total of X

$\sum_{i=1}^n Y_i$ = Grand total of Y

n = Number of observation

n-1 = Degrees of freedom

i = 1,2,3n

Σ = Summation

The expectation of mean cross product (MCP) was derived as follows:

Table 3.1.2.2. Analysis of covariance

Source of variation	df	MS	EMS
Replication (R)	2		$\sigma^2_{12} + G\sigma^2_{R12}$
Inbred line (G)	24		$\sigma^2_{12} + \sigma^2_{R12} + RL\sigma^2_{12}$
G×R	48		$\sigma^2_{12} + R\sigma^2_{GY_{12}} + R\sigma^2_{Y_{12}}$
Error (E)	300		σ^2_{12}

$G\sigma^2_{R12}$ = Covariance due to replication.

$R\sigma^2_{G12}$ = Covariance due to genotype

$R\sigma^2_{GY_{12}}$ = Covariance due to G×Y.

σ^2_{12} = Covariance due to error.

The phenotypic ($\sigma^2_{P_{12}}$), genotypic ($\sigma^2_{g_{12}}$), interaction ($\sigma^2_{GR_{12}}$) and error covariance (σ^2_{12}) were determined as follows:

Step-1

$$\sigma^2_{g_{12}} = (\text{MCP}_g - \text{MCP}_{g \times r})/R$$

$$\sigma^2_{GR_{12}} = (\text{MCP}_{g \times r} - \text{MCP}_e)/R$$

$$\sigma^2_{12} = \text{MCP}_e$$

Step-2

a. Phenotypic covariance ($\sigma^2_{P_{12}}$) = $\sigma^2_{g_{12}} + \sigma^2_{12}$

b. Genotypic covariance ($\sigma^2_{g_{12}}$) = $\sigma^2_{g_{12}}$

(xii) Correlation coefficient

The correlation coefficient at phenotypic (r_p), genotypic (r_g) and environmental (r_e) levels were calculated as follows:

$$r_p = (\sigma^2_{p_{12}}) / (\sigma^2_{p_{11}} \times \sigma^2_{p_{22}})^{1/2}$$

$$r_g = (\sigma^2_{g_{12}}) / (\sigma^2_{g_{11}} \times \sigma^2_{g_{22}})^{1/2}$$

$$r_e = (\sigma^2_{e_{12}}) / (\sigma^2_{e_{11}} \times \sigma^2_{e_{22}})^{1/2}$$

Where,

$\partial^2 p_{12}$, $\partial^2 g_{12}$ and $\partial^2 e_{12}$ represent phenotypic, genotypic and environmental covariance of character 1 and 2. $\partial^2 p_{11}$, $\partial^2 g_{11}$ and $\partial^2 e_{11}$ represent phenotypic, genotypic and environmental levels of character 1. $\partial^2 p_{22}$, $\partial^2 g_{22}$ and $\partial^2 e_{22}$ indicate variance at phenotypic, genotypic and environmental levels of character 2.

(xiii) Path coefficient

The path coefficient analysis was carried out using the formula and Wright (1923) as illustrated by Dewey and Lu (1959). The path-coefficient analysis was done at both phenotypic and genotypic levels by solving the simultaneous equation using matrix method.

The form of equation is as follows:

$$r_{xy} = P_{xy} + r_{x2} P_{2y} + r_{x3} P_{3y} + \dots + r_{xn} P_{ny}$$

Where,

r_{xy} = correlation between one components character and yield.

P_{xy} = Path-coefficient between the same character and yield.

$r_{x2}, r_{x3} \dots r_{xn}$ = Represent correlation coefficient between that character and each of the other yield components in turn.

The above equation was written in a matrix form as:

$$\begin{matrix} & \text{A} & & \text{B} & & \text{C} \\ \begin{bmatrix} r_{1y} \\ r_{2y} \\ r_{3y} \\ r_{iy} \end{bmatrix} & = & \begin{bmatrix} r_{11} & r_{12} & r_{13} & r_{1J} \\ r_{21} & r_{22} & r_{23} & r_{2J} \\ r_{31} & r_{32} & r_{33} & r_{3J} \\ r_{i1} & r_{i2} & r_{i3} & r_{iJ} \end{bmatrix} & \times & \begin{bmatrix} P_{1y} \\ P_{2y} \\ P_{3y} \\ P_{iy} \end{bmatrix}
 \end{matrix}$$

$$A = B \times C; \text{ Then } C = B^{-1} A$$

Where,

P_{ry} = direct effect of the character i on the dependent trait y (yield).

The indirect effect of a particular character through other characters was obtained by multiplication of direct path and particular correlation coefficient between those two characters respectively.

$$\text{Indirect effect} = r_{ij} \times P_{iy}$$

Where,

$$i = 1, \dots, n,$$

$$j = 1, \dots, n,$$

$$P_{iy} = P_{1y} \dots P_{ny}$$

Where, r_{ij} = correlation coefficient between two independent characters.

The residual effect is assumed to be independent to the remaining variables. It was calculated from the formula as proposed by Wright (1923).

$$\text{Residual effect } (\chi) = 1 - R^2$$

$$R^2 = P_{1y} + P_{2y} r_{2y} + \dots + P_{ny} r_{ny}$$

R^2 is the required multiple correlation coefficient and is the amount of variation in yield that can be accounted for by the component characters.

(xiv) Selection index

The coefficients, b_1, b_2, \dots, b_n used in the discriminant function technique was obtained from the genotypic and phenotypic variances and covariances arranged in the matrix as follow:

$$\begin{bmatrix} X \\ X_{11} & X_{12} & X_{13} & X_{1j} \\ X_{21} & X_{22} & X_{23} & X_{2j} \\ X_{31} & X_{32} & X_{33} & X_{3j} \\ X_{i1} & X_{i2} & X_{i3} & X_{ij} \end{bmatrix} \begin{bmatrix} b \\ b_1 \\ b_2 \\ b_3 \\ b_n \end{bmatrix} = \begin{bmatrix} G \\ G_{11} & G_{12} & G_{13} & G_{1j} \\ G_{21} & G_{22} & G_{23} & G_{2j} \\ G_{31} & G_{32} & G_{33} & G_{3j} \\ G_{i1} & G_{i2} & G_{i3} & G_{ij} \end{bmatrix} \begin{bmatrix} a \\ a_1 \\ a_2 \\ a_3 \\ a_n \end{bmatrix}$$

The solution of this matrix gave the estimates of 'b' values in the following manner (Singh and Chaudhury, 1985).

$$b = X^{-1} GA$$

Where,

'b' is the column vector, X^{-1} , is the inverse of phenotypic variance and covariance matrix, 'G' is the genotypic variance and covariance matrix and 'a' is the column vector for economic weights. Assuming that all the characters are of economically equal importance, i.e., $a_1 = a_2 = a_3 = 1$.

The values obtained for b_1, b_2, \dots, b_n were used in discriminant function selection technique. The phenotypic and genotypic variances and covariances as obtained were used for constructing the discriminant function using different character combinations according to the method as developed by Fisher (1925) and Smith (1936). Yield/plant was also included as one of the independent characters as suggested by Robinson *et al.* (1951). The expected genetic advance from straight selection {GA(S)} and from discriminant function {GA(D)} was calculated as follows:

$$GA(S) = (Z/P) \times (g_{yy}) / (t_{yy}) \frac{1}{2} \text{ and}$$

$$GA(D) = (Z/P) \times (b_1 g_{1y} + b_2 g_{2y}) \frac{1}{2}$$

Where,

Z/P = the selection differential in standard units, for the present study it was 2.06 at 5% level of selection (Lush, 1949).

g_{yy} and t_{yy} = the genotypic and phenotypic variances of character.

b_1, b_2, \dots, b_n = the relative weights for character.

g_{1y}, g_{2y}, \dots = the genotypic co variances of independent character with y.

The expected gain from the discriminant function over straight selection was calculated for all the functions as shown below:

$$\text{Expected gain (\%)} = [GA(D)/GA(S)] \times 100.$$

(xv) Genetic divergence

After analysis of variance and covariance, the data were D^2 statistics. First, D^2 values of all the individual population is (n-1) combinations were arranged in ascending order. After arranging the D^2 values in this manner a method suggested by Rao (1952) was used for cluster formation.

After formation of the cluster on the basis of D^2 values, the average intra-cluster D^2 values were obtained by the formula $\frac{\sum di^2}{n}$ where $di^2 =$ sum of the distances between all possible combinations (n) of the populations included in a cluster. In this way, average inter-cluster D^2 values were also obtained between any two groups. The square roots of the D^2 values represented the distance between and within groups. A measure for group distance based on multiple characters was given by Mahalanobis (1936).

With $x_1, x_2, x_3, \dots, x_p$ as the d_p as $\bar{x}_1^1 - \bar{x}_1^2, \bar{x}_2^1 - \bar{x}_2^2, \dots, \bar{x}_p^1 - \bar{x}_p^2$, respectively, being the difference in the means of two populations, Mahalanobis' D^2 – statistics is defined as follows:

$${}_pD^2 = b_1d_1 + b_2d_2 + \dots + b_p d_p$$

Here,

The b_i value is to be estimated such that the ratio of variance between the populations to the variance within the populations is maximized. In terms of variances and covariance, the D^2 value is obtained as follows:

$${}_pD^2 = W^{ij} (\bar{x}_i^1 - \bar{x}_i^2)(\bar{x}_j^1 - \bar{x}_j^2) \dots (1)$$

Where,

W^{ij} is the inverse of estimated variance co-variance matrix.

EXPERIMENT II

3.2.1 MATERIALS

The genetic materials used in this experiment were six parents (IL₄=P₁, IL₅=P₂, IL₁₈=P₃, IL₁₀=P₄, IL₂₃=P₅ and IL₁=P₆) and their F₁ which were P₁×P₂, P₁×P₃, P₁×P₄, P₁×P₅, P₁×P₆, P₂×P₃, P₂×P₄, P₂×P₅, P₂×P₆, P₃×P₄, P₃×P₅, P₃×P₆, P₄×P₅, P₄×P₆ and P₅×P₆.

3.2.2 METHODS

Field Experiment

The present investigation was carried out during 26 November 2009 and 28 November 2010 seasons at the experimental field, Department of Botany, University of Rajshahi, Bangladesh.

The genetic materials were crossed in half diallel fashion in 26 November 2009 and to obtain the F₁ seeds. The F₁ seeds of all the crosses with their parents were planted in the field in 28 November 2010 season for evaluation in a randomized block design with three replications. The experimental unit was single row of 3 m long. Inter-plant and inter-row distances were 10 and 30 cm, respectively. All other treatments were kept constant for the whole experiment.

Collection of Data

Five plants from each row were randomly selected for recording data on the studied characters such as days to tasseling, days to silking, days to maturity, plant height, ear height, cob length, cob diameter, number of rows/cob, number of kernels/row, number of kernels/cob and grain yield/plant.

Techniques of Statistical Analysis of Data

(i) Diallel and Combining Ability Analysis

The collected data were analyzed following the biometrical techniques of analyses according the Method 1 (Parents+F₁s = half diallel) given by Griffings

(1956). In this study, six parents ($n=6$) were involved in the diallel, producing 15 F_1 s [$n(n-1)/2$] and without reciprocals i.e., there were 21 total entries, 15 crosses and 6 parents. Techniques of analyses of the data are described under the following sub-heads:

Testing the significance differences

The data were first analyzed to test the significance of crossing differences. If the mean squares due to crossing are significant, there is need to proceed for further analyses. The total variability in the treatments was partitioned into components like variance due to replication, crosses (including parents), interaction ($C \times R$) and within error.

The sums of squares were calculated as follows:

$$\text{Correction factor} = (\text{Grand total})^2 / r \times (n \times n) \times s$$

$$\text{Total}_{ss} = \text{Individual observation}^2 - \text{CF}$$

$$\text{Treatment}_{ss} = \sum X_i^2 / s - \text{CF}$$

$$\text{Replication}_{ss} = \frac{\sum X_j^2}{c \times s} - \text{CF}$$

$$\text{Cross (including parents)}_{ss} = \sum X_k^2 / rs - \text{CF}$$

$$C \times R_{ss} = \text{Total}_{ss} - \text{Treatment}_{ss} - \text{Replication}_{ss}$$

$$\text{Within error}_{ss} = \text{Total}_{ss} - \text{Treatment}_{ss}$$

Here, X_i = Replication total

X_j = Treatment total

X_k = Cross (including parents) total

r = Number of replications

n = Number of parents

c = Number of crosses ($n \times n$)

s = Number of plants or sibs

Table 3.2.1.1. Preparation of ANOVA

Sources of variation	df	SS	MS	EMS	VR ₁	VR ₂
Treatment	74	SS ₁	SS ₁ /df = MS ₁		MS ₁ /MS ₅	MS ₁ /MS ₄
Replication(R)	2	SS ₂	SS ₂ /df = MS ₂	$\sigma^2w_{11} + \dots + cs\sigma^2R_{11}$	MS ₂ /MS ₅	MS ₂ /MS ₄
Crosses (C) (including parents)	21	SS ₃	SS ₃ /df = MS ₃	$\sigma^2w_{11} + s\sigma^2I_{11} + rs\sigma^2C_{11}$	MS ₃ /MS ₅	MS ₃ /MS ₄
Interaction (I) (C×R)	48	SS ₄	SS ₄ /df = MS ₄	$\sigma^2w_{11} + s\sigma^2I_{11}$		
Within error (W)	300	SS ₅	SS ₅ /df = MS ₅	σ^2w_{11}		
Total	374					

Estimation of variance and covariance

A number of first and second degree statistics (Mather, 1955) were calculated from the mean data. With the environmental expectation (E) included, the statistics of the above parameters may be shown as follows (Hayman, 1954 b):

$$\text{Parental mean} = \frac{\text{Sum of all the diagonal values}}{\text{Number of parents}}$$

$$V_0L_0 = \frac{1}{n-1} \left[\sum \text{Diagonal values}^2 - \frac{(\sum \text{Diagonal values})^2}{\text{Number of diagonal values}} \right]$$

$$V_r = \frac{1}{n-1} \left[\sum \text{Crosses involving a particular parent}^2 - \frac{(\sum \text{Crosses involving a particular parent})^2}{\text{Num of parents}} \right]$$

$$V_1L_1 = \frac{1}{n} \sum V_{ri}$$

$$W_r = \left[\sum \text{Arrays} \times \text{no - recurring parents} - \frac{\sum \text{Arrays} \sum \text{Diagonal values}}{\text{Number of parents}} \right]$$

$$W_0L_0 = \frac{1}{n} \sum W_{ri}$$

$$V_0L_1 = \frac{1}{n-1} \left[\sum \text{Array means}^2 - \frac{(\sum \text{Array means})^2}{\text{Number of arrays}} \right]$$

$$(ML_1 - ML_0)^2 = \left[\frac{1}{n} \left\{ \frac{1}{n} \text{Grand total} - \text{Diagonal values} \right\} \right]^2$$

The above statistics may be defined as follows:

$$V_0L_0 = \text{Variance of parents.}$$

V_r = Variance of each array.

V_1L_1 = Mean variance of the arrays.

W_r = Covariance between parents and their offsprings.

W_0L_0 = Mean covariance between the parents and the arrays.

V_0L_1 = Variance of the mean arrays.

$(ML_1 - ML_0)^2$ = The difference between the mean of the parents and the mean of their n^2 progenies.

The environmental variation (E) is calculated by using the following formula:

$$E = 1/r \left\{ \frac{\text{Interaction Error ss} + \text{Within Error ss} + \text{Rep. ss}}{\text{Interaction Error df} + \text{Within Error df} + \text{Rep. df}} \right\}$$

Testing the validity of the hypothesis

The probable fulfillment of the hypothesis (Hayman, 1954 b) is tested by using the following formula:

$$t^2 = \frac{n-2}{4} \left[\frac{\{\text{Var}(V_r) - \text{Var}(W_r)\}^2}{\text{Var } V_r \times \text{Var } W_r - \text{Cov}^2(V_r, W_r)} \right]$$

Which is an F with 4 and $(n-2)$ degrees of freedom.

When,

$$\text{Var}(W_r) = \frac{1}{n-1} \left[\{W_{ri}^2 - \frac{(\sum W_{ri})^2}{n}\} \right]$$

$$\text{Var}(V_r) = \frac{1}{n-1} \left[\{V_{ri}^2 - \frac{(\sum V_{ri})^2}{n}\} \right]$$

$$\text{Cov}(V_r, W_r) = \frac{1}{n-1} \left[\{V_r W_r - \frac{\sum V_r \sum W_r}{n}\} \right]$$

Here,

$\text{Var}(W_r)$ = Variance of W_r

$\text{Var}(V_r)$ = Variance of V_r

$\text{Cov}(V_r, W_r)$ = Covariance between V_r and W_r

This is tested against the table value of “F” with 4 and $(n - 2)$ degrees of freedom. Its significance indicates failure of the hypothesis. Another way of testing the hypothesis is through the regression coefficient, calculated by using the following formula:

$$b = \frac{\text{Cov}(V_r, W_r)}{\text{Var}(V_r)}$$

Where,

$$\text{Cov}(W_r, V_r) = \left[\sum V_r W_r - \frac{\sum V_r \sum W_r}{n} \right] / (n - 1) \quad \text{and}$$

$$\text{Var}(V_r) = \left[\sum V_r^2 - \frac{(\sum V_r)^2}{n} \right] / (n - 1)$$

Therefore,

$$b = \frac{\text{Cov}(W_r, V_r)}{\text{Var}(V_r)}$$

$$\text{Standard error (b)} = [(\text{Var } W_r - b \text{ Cov } W_r V_r) / \text{Var } V_r (n - 2)]^{1/2}$$

Now the significance of b from zero and unity can be tested as follows:

$$\begin{aligned} H_0 b &= 0 \\ &= (b - 0) / \text{SE}(b) \text{ and} \end{aligned}$$

$$\begin{aligned} H_0: b &= 1 \\ &= (1 - b) / \text{SE}(b) \end{aligned}$$

These values are tested against table value of “t” for $(n - 2)$ degrees of freedom.

Components of variation and their proportions

The expected values of the components of variation obtained by least square computations are as follows:

$$D = V_0 L_0 - E$$

$$F = 2V_0 L_0 - 4W_0 L_{01} - 2(n - 2) E/n$$

$$H_2 = 4V_1 L_1 - 4V_0 L_1 - 2E$$

$$h^2 = 4 (ML_1 - ML_0)^2 - 4 (n - 1) E/n^2$$

$$Fr = 2 (V_0L_0 - W_0L_{01} + V_1L_1 - W_r - V_r) - 2 (n - 2) E/n$$

The above components are genetic parameters:

D = Variation due to additive effect. F = The mean of “Fr” over the arrays.

H₁ = Component of variation due to the dominance effect of the genes.

h² = Dominance effect (as algebraic sum over all loci in heterozygous phase in all crosses).

Fr = The covariance of additive and dominance effects in a single array.

$$H_2 = H_1 [1 - (u - v)^2]$$

Where, U = Proportion of positive genes in the parents.

V = Proportion of negative genes in the parents.

$$\text{Thus, } H_2 = 4V_1L_1 - 4V_0L_1 - 2E$$

For testing the significance of each of these components, respective standard errors were calculated. Here the common multiplier or variance (S²) was calculated using the following formula:

$$S^2 = \frac{1}{2} [\text{Var} (W_r - V_r)]$$

And the specific multiplier was calculated with the following formula:

$$D = (n^5 + n^4)/n^5$$

$$F = (4n^5 + 20n^4 - 16n^3 + n^2)/n^5$$

$$H_1 = (n^5 + 41n^4 - 12n^3 + 4n^2)/n^5$$

$$H_2 = (36n^4)/n^5$$

$$h^2 = (16n^4 + 16n^2 - 32n + 16)/n^5$$

$$E = n^4/n^5$$

The standard errors for the different estimates were then calculated using the specific multiplier and common multiplier, which are as follows:

$$SE (D) = \{ \text{Specific multiplier} \times \text{Common multiplier} (s^2) \}^{1/2}$$

Graphical analysis

Diallel analysis for the components of genetic variances and Vr-Wr graphs for all the characters studied were done according to Hayman (1954a, b).

A diallel table was prepared from the averages over all the three replicates and the following statistics were estimated. Vr = Variance of all progenies in each parental array (an array is a group of crosses involving a particular parents).

Wr = Covariance between parents and their offspring in each array. The validity of Hayman's hypothesis was tested for all the characters studied by the equation.

Combining ability analysis

In the combining ability analysis the data are rearranged in Table 3.4. In this table, each value is the mean value in all the replications. The total variability in the population may, therefore, be partitioned into components like variance due to general combining ability (gca), specific combining ability (sca) and error. Using replicate mean the various sum of squares are obtained as follows:

$$\text{ss due to gca} = \frac{1}{2n} \left[\sum (Y_{i.} + Y_{.j})^2 - \frac{2}{n} Y_{..}^2 \right]$$

$$\text{ss due to sca} = 1/2 \sum \sum Y_{ij}(Y_{ij} + Y_{ji}) - 1/2n \sum (Y_{.j} + Y_{i.})^2 + 1/n^2 Y^2$$

Table 3.2.1.2. ANOVA for combining ability in method I

Source	df	SS	MS	EMS
gca	5	SS ₁	MS _g	$\sigma^2_e + \sigma^2_g \cdot 2(n-1) / n + 2n\sigma^2_g$
sca	14	SS ₂	MS _s	$\sigma^2_e + 2(n^2 - n + 1) \sigma^2_s / n^2$
Error	40	SS ₃	MSe	σ^2_e

Where,

gca = General combining ability.

sca = Specific combining ability.

Y_{ij} = Mean of $i \times j$ th cross

MSg = Mean square of gca effects.

MSs = Mean square of sca effects.

MSe = Mean square of error.

The mean of sum of squares due to error divided by the number of replications. Mean error variance, MS_g and MS_s have been calculated from the mean data, mean error variance is therefore, required for F-test.

$$\text{Thus } MS'(\text{error}) = \frac{MS(\text{error})}{\text{Number of replications}}$$

The general combining ability effects are defined as follows:

$$g_i = 1/2n(Y_{i.} + Y_{.j}) - 1/n^2Y_{..}$$

The specific combining ability effects are defined as follows:

$$S_{ij} = 1/2(Y_{ij} + Y_{ji}) - 1/2n(Y_{i.} + Y_{.i} + Y_{.j} + Y_{jj}) + 1/n^2Y_{..}$$

(ii) Heterosis Study

A diallel cross of 6×6 excluding reciprocals for obtaining F_1 was conducted in the period from October, 2010 to March, 2011 was the materials of this investigation. Data on eleven quantitative traits were analyzed following the techniques given below. Techniques of the analysis of data:

Estimation of mid-parent and better-parent

For estimation of heterosis in each parameter the mean values of the 15 F_1 s have been compared with better-parents (BP) for heterobeltosis and with mid-parent (MP) for heterosis over mid parent value.

Percent heterosis was calculated as

$$\text{Heterosis (MP)} = \frac{\bar{F}_1 - \text{MP}}{\text{MP}} \times 100$$

$$\text{Heterosis (BP)} = \frac{\bar{F}_1 - \text{BP}}{\text{BP}} \times 100$$

Standard error for each individual and overall heterosis was calculated. Significance tests for heterosis were done by using pooled error from the analysis of variance of F_1 and parental populations.

$$\text{Mid-parent} = 1/2(P_1 + P_2)$$

$$\text{Variance of mid-parent} = 1/4(VP_1 + VP_2)$$

$$\text{Variance of } F_1 = VF_1$$

$$\text{Standard error of mean of MP and } F_1 = \sqrt{1/4VP_1 + 1/4VP_2 + VF_1}$$

Here, N = Total number of populations ($P_1 + P_2 + F_1$)

t = Estimated value of MP heterosis / Standard error of mean

$$\text{Standard of error of mean of BP} = \sqrt{VBP} / N$$

Here, N = Total number of populations (F_1)

t = Estimated value of BP heterosis / standard error of mean of BP

A general specification of heterosis must, therefore, be able to accommodate heterosis both in the positive ($F_1 > P_1$) and in the negative ($F_1 < P_2$) directions.

If heterosis is measured on a scale on which an additive–dominance model is adequate, then for positive heterosis, its expected magnitude is given by

Heterosis = $\bar{F}_1 - P_1 = [h] - [d]$ and for heterosis to occur $[h]$ must be positive and greater than $[d]$. For negative heterosis the comparable expectation is given

by Heterosis = $\bar{F}_1 - P_2 = [h] - (-[d])$ and heterosis will occur only when $[h]$ is

negative and greater than [d]. If the additive–dominance model is inadequate, its specification becomes complex.

Test of significance for heterosis

The significance of heterosis was tested with the help of critical difference (CD) (Mian, 1985; Singh and Narayanan, 1993).

CD= SE of difference + “t” at 5% or 1% level of probability at respective degrees of freedom.

$$SE(H_1)=\sqrt{(3/2\times V_e/r)}$$

$$SE(H_1)=\sqrt{(2\times V_e/r)}$$

Where,

V_e = error mean square of the ANOVA involving parents, F_1 s and the commercial/ cultivated variety.

RESULTS

Experiment I

In the present study 25 maize inbred lines were evaluated for eleven quantitative characters *viz.*, days to tasseling, days to silking, days to maturity, plant height, ear height, cob length, cob diameter, no. of rows/cob, no. of kernels/row, no. of kernels/cob and grain(kernel)yield/plant. Collected data were analyzed in order to estimate mean with standard error, coefficient of variability, heritability, genetic advance, genetic advance as percentage of mean, correlation coefficient, path coefficient, selection index and genetic diversity with D^2 - statistics. The results derived from these different statistical analyses are described under different heads.

4.1.1 GENETIC VARIABILITY

Mean with Standard Error and Coefficient of Variability

Mean with standard error (SE) and coefficient of variability as percentage (CV %) for eleven characters for twenty five maize inbred lines was calculated from the pooled data and the results are shown in Tables 4.1.1- 4.1.6. The maximum days to tasseling (83.667) was recorded for IL-15, whereas the lowest days to tasseling (65.265) were noted for IL-4. On the other hand, CV% was highest in inbred line IL-10 and lowest in IL-5 for the days to tasseling (Table 4.1.1). The maximum days to silking (94.267) was exhibited by IL4, while the minimum value (84.667) was observed in IL-18. The highest CV% was recorded in IL-18 and the lowest in IL-7 (Table 4.1.1). The maximum days to maturity (129.733) was noted in IL-5 while the lowest (114.733) was in IL-10. The highest CV% was noted in IL-10 and the lowest CV% in IL-2 (Table 4.1.2). The highest plant height (111.529) was exhibited by IL-4, IL-5 and IL1-5 and the lowest was noted for IL-1 (96.459). The maximum CV% was recorded in IL-24 and the minimum in IL-3 and IL-13 (Table 4.1.2).

For ear height, the highest mean was recorded in IL-24, IL-21 (52.470) and the lowest mean was recorded in IL-1 and IL-2 (36.677). The highest CV% was noted in IL-14 and the lowest CV% was noted in IL-24 (Table 4.1.3).

The highest cob diameter was noted in IL-19, IL-17, IL-22, IL-14 (13.414) and the lowest was noted in IL-21 (9.933). The highest CV% was noted in IL-4 and IL-18 and the lowest in IL-12 (Table 4.1.3). For cob length, the maximum (13.181) was recorded in IL-24, IL-9 and the lowest (9.996) was recorded in the IL-2. The highest CV% was noted in the IL-15 and IL-21 and the lowest was noted in IL-3 (Table 4.1.4).

The maximum number of rows/cob (13.333) was noted in IL-23 while the lowest (10.733) was noted in IL-5. The highest CV% was noted in IL-2 and IL-22 and the lowest CV% in IL-7 (Table 4.1.4). For number of kernels/row, the maximum (15.333) was recorded in IL-4 and IL-13 and the minimum (12.600) was recorded in IL-22. The highest CV% was noted in IL-13 and the lowest was noted in IL-22 (Table 4.1.5). The maximum number of grains/cob was noted in IL-18 (72.133) and the lowest was noted in IL-8 (63.533). The highest CV% was noted in IL-10 and the lowest in IL-11 and IL-9 (Table 4.1.5). For grain yield (grain weight/plant), the maximum (84.904 g) was recorded in the inbred line IL-1 and the lowest (65.577 g) was recorded in IL-21.

The highest CV% was noted in IL-15 and the lowest was noted in IL-4 (Table 4.1.6). Twenty five inbred lines were evaluated to find out the extent of genetic variability for the respective characters (days to tasseling, days to silking, days to maturity, plant height, ear height, cob length, cob diameter, number of kernel rows/ear, number of kernels/row, number of grains/cob and grain yield/plant). Significant variations were existed among the inbred lines for the characters studied. Mean performances of 25 inbred lines are presented in Tables 4.1.1-4.1.6.

Duration of silking ranged from 84.667 to 94.266 days. The inbred line IL-4 and IL-5 took the longest time to silk and maturity which was statistically different from the other inbreds.

Inbreds IL-18, IL-10 and IL-23 took the shortest period for silking and maturity and were statistically different from the others. IL-4, IL-5 and IL-15 were the tallest inbred lines which were statistically identical with IL-3 and IL-19. The shortest height was produced by IL-1. Inbreds IL-21 and IL-24 showed the highest ear height where as IL-1 and IL-2 appeared as the shortest for the height. The inbred lines IL-19 and IL-24 showed the highest mean performance for ear length and appreciable ear diameter. Inbred line IL-23 had the highest number of kernel rows/cob which was statistically identical with IL-19 and IL-18.

The highest number of kernels/row was recorded in IL-6. Number of grains/cob ranged from 63.533 to 72.134. The grain yield/plant (weight/plant) ranged from 65.523 to 84.904 g. The inbred line IL-1 produced the highest grain yield which was statistically similar with IL-23, IL-18 and IL-14. Yield performance of IL-4 was poor. So, the best performance was observed in IL-4, IL-5, IL-18, IL-10, IL-23 and IL-1 inbred lines on the basis of tasseling, flowering and different important characters.

Table 4.1.1. Mean with SE, CV % for days to tasseling and days to silking of 25 inbred lines of maize

Inbred lines	Days to tasseling		Days to silking	
	Mean±SE	CV%	Mean±SE	CV%
IL-1	78.600±1.530	7.5391	88.865±0.930	4.054
IL-2	76.866±1.555	7.8346	90.867±1.009	4.300
IL-3	70.265±1.675	9.2304	92.534±0.975	4.082
IL-4	65.264±1.026	6.0866	94.265±0.796	3.269
IL-5	75.867±0.956	4.8779	93.736±0.796	3.287
IL-6	74.134±1.068	5.5820	89.667±1.330	5.744
IL-7	71.933±1.329	7.1557	91.200±0.579	2.459
IL-8	67.865±1.576	8.9951	91.800±0.611	2.578
IL-9	72.933±1.148	6.0981	92.134±0.990	4.161
IL-10	75.800±2.664	13.6119	92.535±0.668	2.796
IL-11	75.000±1.082	5.5891	93.067±0.628	2.615
IL-12	72.266±1.119	5.9968	92.736±0.918	3.834
IL-13	77.200±1.096	5.5000	91.534±0.755	3.195
IL-14	75.134±1.383	7.1297	91.538±0.682	2.887
IL-15	83.667±2.184	10.1082	91.337±0.591	2.506
IL-16	74.934±1.307	6.7572	89.400±0.872	3.777
IL-17	78.465±1.764	8.7087	88.269±0.733	3.218
IL-18	74.935±1.416	7.3176	84.663±1.701	7.779
IL-19	79.266±1.465	7.1598	90.937±1.322	5.630
IL-20	80.200±1.808	8.7307	92.800±1.176	4.908
IL-21	76.066±2.207	11.2374	87.937±1.343	5.916
IL-22	77.400±1.588	7.9464	87.338±0.860	3.814
IL-23	78.600±2.210	10.8894	91.539±0.689	2.916
IL-24	79.067±1.777	8.7032	90.737±1.569	6.697
IL-25	79.865±1.496	7.2526	87.334±1.508	6.686
	LSD =6.822		LSD= 6.551	

Table 4.1.2. Mean with SE, CV % for days to maturity and plant height (cm) of 25 inbred lines of maize

Inbred lines	Days to maturity		Plant height	
	Mean±SE	CV%	Mean±SE	CV%
IL-1	124.665±0.659	2.0488	96.459±1.447	5.811
IL-2	122.600±0.524	1.654	101.223±1.648	6.306
IL-3	124.734±0.556	1.7265	108.927±1.332	4.737
IL-4	123.738±0.714	2.235	111.529±1.961	6.811
IL-5	129.780±0.796	2.376	111.123±2.101	7.323
IL-6	127.812±1.135	3.438	106.630±1.542	5.600
IL-7	125.600±0.809	2.496	106.300±1.943	7.081
IL-8	125.134±0.970	3.005	103.153±2.412	9.056
IL-9	123.150±1.009	3.173	104.307±1.806	6.706
IL-10	114.735±3.202	10.808	104.793±2.297	8.488
IL-11	124.732±1.333	4.137	103.079±2.026	7.611
IL-12	123.401±1.644	5.159	101.869±1.888	7.179
IL-13	123.800±1.314	4.109	99.257±1.228	4.791
IL-14	120.335±1.804	5.805	100.503±2.222	8.564
IL-15	123.370±0.950	2.981	111.007±1.860	6.488
IL-16	124.665±0.766	2.380	104.975±2.107	7.774
IL-17	122.136±1.664	5.278	105.394±2.238	8.223
IL-18	125.930±0.848	2.607	104.053±1.846	6.871
IL-19	122.920±1.136	3.578	106.065±2.141	7.817
IL-20	124.825±1.294	4.014	98.586±1.855	7.287
IL-21	124.461±1.059	3.296	106.351±1.677	6.108
IL-22	118.412±1.447	4.732	104.735±1.976	7.307
IL-23	117.465±1.064	3.508	97.860±2.896	11.459
IL-24	119.861±2.225	7.189	100.483±3.434	13.235
IL-25	121.012±0.946	3.028	101.740±1.999	7.611
	LSD = 7.359		LSD=12.057	

Table 4.1.3. Mean with SE, CV % for ear height (cm) and cob diameter (cm) of 25 inbred lines of maize

Inbred lines	Ear height		Cob diameter	
	Mean±SE	CV%	Mean±SE	CV%
IL-1	39.160±1.789	17.69	10.553±0.339	12.451
IL-2	39.677±1.346	13.142	11.682±0.358	11.879
IL-3	45.058±2.205	18.949	10.839±0.351	12.552
IL-4	41.913±1.744	16.119	11.884±0.429	13.983
IL-5	43.260±0.963	8.62	12.216±0.403	12.778
IL-6	47.546±2.012	16.387	10.536±0.47	17.278
IL-7	48.817±1.415	11.227	11.391±0.507	17.224
IL-8	50.281±1.173	9.034	12.283±0.39	12.304
IL-9	48.330±1.352	10.838	10.863±0.48	17.099
IL-10	44.965±2.228	19.194	12.299±0.468	14.726
IL-11	51.768±1.516	11.342	10.637±0.37	13.454
IL-12	49.764±2.177	16.942	12.562±0.289	8.905
IL-13	48.578±2.457	19.593	12.748±0.367	11.154
IL-14	50.643±2.858	21.857	13.080±0.238	7.047
IL-15	47.139±1.554	12.771	10.043±0.307	11.845
IL-16	46.287±1.689	14.134	12.977±0.343	10.229
IL-17	50.021±2.074	16.057	13.153±0.383	11.276
IL-18	49.160±2.323	18.302	12.284±0.435	13.726
IL-19	48.915±2.164	17.131	13.415±0.327	9.455
IL-20	49.043±2.129	16.811	11.696±0.349	11.563
IL-21	52.559±1.944	14.33	9.935±0.35	13.628
IL-22	49.930±1.322	10.258	13.217±0.409	11.988
IL-23	50.761±2.091	15.951	12.754±0.452	13.719
IL-24	52.470±1.048	7.738	12.339±0.384	12.058
IL-25	46.089±2.308	19.396	11.537±0.332	11.134
LSD = 7.359			LSD=12.057	

Table 4.1.4. Mean with SE, CV % for cob length (cm) and for number of row/cob of 25 inbred lines of maize

Inbred lines	Cob length		Number of rows/cob	
	Mean±SE	CV%	Mean±SE	CV%
IL-1	10.901±0.318	11.315	12.134±0.435	13.885
IL-2	9.996±0.230	8.908	11.868±0.542	17.696
IL-3	12.012±0.237	7.627	11.867±0.413	13.463
IL-4	11.551±0.373	12.522	11.334±0.303	10.369
IL-5	12.055±0.361	11.561	10.738±0.463	16.691
IL-6	12.303±0.395	12.423	12.736±0.463	14.069
IL-7	10.829±0.392	14.004	12.467±0.274	8.503
IL-8	12.226±0.415	13.154	11.734±0.33	10.908
IL-9	13.095±0.330	9.748	11.400±0.412	13.988
IL-10	12.926±0.526	15.754	11.866±0.477	15.56
IL-11	11.911±0.391	12.712	11.938±0.316	10.247
IL-12	11.960±0.335	10.851	12.135±0.435	13.885
IL-13	10.959±0.36	12.722	11.936±0.316	10.247
IL-14	11.581±0.418	13.984	11.464±0.291	9.815
IL-15	11.225±0.479	16.533	11.931±0.396	12.853
IL-16	10.898±0.402	14.284	12.601±0.375	11.54
IL-17	10.246±0.389	14.688	12.000±0.39	12.599
IL-18	11.005±0.451	15.862	13.002±0.352	10.483
IL-19	12.433±0.466	14.518	13.200±0.49	14.374
IL-20	11.616±0.372	12.412	12.401±0.349	10.905
IL-21	10.692±0.449	16.265	11.266±0.396	13.613
IL-22	12.389±0.400	12.496	11.934±0.53	17.193
IL-23	11.598±0.460	15.356	13.266±0.473	13.801
IL-24	13.181±0.310	9.11	12.334±0.287	9.022
IL-25	12.225±0.441	13.946	12.067±0.371	11.914
LSD= 2.5606			LSD= 2.563	

Table 4.1.5. Mean with SE, CV % for number of kernes/row and number of grains/cob of 25 inbred lines of maize

Inbred lines	Number of kernels/row		Number of grains/cob	
	Mean±SE	CV%	Mean±SE	CV%
IL-1	14.600±0.375	9.959	68.732±2.409	13.576
IL-2	13.534±0.376	10.768	66.001±1.93	11.324
IL-3	14.00±0.436	12.074	69.136±1.956	10.96
IL-4	15.334±0.433	10.932	66.864±1.561	9.042
IL-5	14.067±0.452	12.449	66.067±1.089	6.383
IL-6	14.735±0.502	13.198	69.000±2.287	12.835
IL-7	12.867±0.363	10.939	67.810±1.831	10.462
IL-8	13.000±0.458	13.637	63.531±1.104	6.727
IL-9	12.739±0.384	11.674	66.400±0.94	5.483
IL-10	13.265±0.441	12.889	69.412±2.635	14.703
IL-11	13.067±0.419	12.43	65.665±0.871	5.137
IL-12	12.938±0.431	12.894	66.732±1.62	9.4
IL-13	15.267±0.539	13.665	68.131±2.394	13.609
IL-14	12.930±0.431	12.894	66.610±1.253	7.285
IL-15	12.739±0.248	7.548	67.665±1.861	10.652
IL-16	13.600±0.335	9.547	67.869±1.226	6.997
IL-17	13.336±0.361	10.48	65.801±1.662	9.785
IL-18	13.612±0.349	9.943	72.132±1.486	7.979
IL-19	13.067±0.267	7.904	65.268±0.897	5.322
IL-20	13.400±0.363	10.478	69.332±2.37	13.238
IL-21	13.335±0.454	13.195	68.269±1.127	6.396
IL-22	12.612±0.214	6.572	66.264±1.274	7.447
IL-23	14.339±0.494	13.359	64.869±1.287	7.683
IL-24	14.412±0.466	12.533	67.605±2.441	13.987
IL-25	14.131±0.456	12.505	71.412±2.428	13.168
LSD= 2.583		LSD= 11.187		

4.1.6. Mean with SE, CV % for grain yield/plant of 25 inbred lines of maize

Inbred lines	Mean±SE	CV%
IL-1	84.904±2.9824	13.604
IL-2	69.478±1.5444	8.6094
IL-3	74.863±1.0745	5.5587
IL-4	65.523±0.4783	2.8273
IL-5	72.057±1.9259	10.351
IL-6	71.326±2.2217	12.064
IL-7	70.768±2.0575	11.26
IL-8	65.679±1.9035	11.225
IL-9	70.674±0.5981	3.2776
IL-10	71.010±2.1374	11.658
IL-11	78.892±1.8962	9.3088
IL-12	71.116±0.6957	3.7887
IL-13	72.955±1.7702	9.3975
IL-14	82.376±1.466	6.8926
IL-15	78.913±3.6075	17.705
IL-16	75.559±2.1471	11.006
IL-17	72.750±0.7011	3.7324
IL-18	82.571±1.5644	7.3381
IL-19	80.540±1.3992	6.7286
IL-20	70.020±0.5706	3.1559
IL-21	65.579±2.1321	12.592
IL-22	79.535±1.7682	8.6101
IL-23	83.998±2.3857	11.002
IL-24	82.066±0.6435	3.0371
IL-25	75.638±1.3539	6.9324
LSD=11.01754		

Analysis of Variance

The analysis of variance for all the eleven characters was done separately and the results are shown in Tables 4.1.7– 4.1.9. For testing the effects of the main items and their interaction effects, a mixed model was followed.

Inbred line (L) item was highly significant at 5% and 1% level for all the characters. The interaction of line with replication (L×R) was also highly significant for most of the characters. Significant line item indicated that there were significant differences among the lines for these characters considered in this study.

Table 4.1.7. Analysis of variance for days to tasseling, days to silking, days to maturity and plant height of 25 inbred lines of maize

Sources of variation	df	Days to tasseling	Days to silking	Days to maturity	Plant height
		MS	MS	MS	MS
Total	374	21.331	19.546	34.610	74.704
Treatment	74	41.372	37.519	97.611	170.041
Line	24	88.225**	79.734**	155.134**	248.028**
Replication	2	64.904	42.674	98.696	305.064
Line×Rep.	48	16.965**	16.196**	68.804**	125.422**
Within error	300	16.388	15.113	19.070	51.187

Table 4.1.8. Analysis of variance for ear height, cob diameter, cob length and number of rows/cob of 25 inbred lines of maize

Sources of variation	df	Ear height	Cob diameter	Cob length	Number of rows/cob
		MS	MS	MS	MS
Total	374	69.119	3.138	2.999	2.621
Treatment	74	136.633	7.330	3.263	3.871
Line	24	197.908**	16.265**	3.672*	5.463*
Replication	2	750.804	0.021	9.739	7.784
Line×Rep.	48	80.405**	3.167**	2.789**	2.911**
Within error	300	52.466	2.105	2.934	2.313

Table 4.1.9. Analysis of variance for number of kernels/row, and number of kernels/cob of 25 inbred lines of maize

Sources of variation	df	Number of kernels/row	Number of kernels/cob	Grain yield/plant
		MS	MS	MS
Total	374	2.954	519.562	47.596
Treatment	74	5.407	942.962	61.907
Line	24	9.395**	947.161**	68.778**
Replication	2	36.642	9760.248	543.050
Line×Rep.	48	2.112**	573.475**	43.425**
Within error	300	2.349	415.124	44.067

Genetic Parameters

The estimates of phenotypic (σ^2_p), genotypic (σ^2_g) and error (σ^2_e) components of variation were calculated separately for all the eleven agronomic characters of twenty five maize inbred lines and the results are presented in the Table 4.1.10.

(i) Phenotypic Variation (σ^2_p)

For all the characters phenotypic variation (σ^2_p) was greater than those of σ^2_g and σ^2_e components of variation as expected. The phenotypic variation is the joint product of σ^2_g and σ^2_e . Table 4.1.10 shows that the greater portion of the total phenotypic variation appeared mostly due to error variation for all the characters. The highest value of σ^2_p was observed for number of grains /cob (1223.911) and the lowest was shown by cob length (5.418). The remaining characters followed with their lower to higher values were as days to silking, plant height, ear height, grain yield/plant, days to tasseling, days to maturity and cob diameter.

(ii) Genotypic Variation (σ^2_g)

The highest genotypic variation (σ^2_g) was found for number of grains/cob with a value of 808.787, while the lowest genotypic variation was recorded for cob length with a value of 3.123 cm.

The other characters according to lower to higher values were as cob length, number of rows/cob, cob diameter, days to maturity, number of kernels/row, ear height, days to tasseling and grain yield/plant (Table 4.1.10.).

(iii) Error Variation (σ^2e)

The highest error variation (σ^2e) was recorded for number of grains/cob with a value of 415.124 and the lowest was noted for cob length with a value of 2.294 cm (Table 4.1.10.).

(iv) Coefficient of Variability

The estimates of phenotypic (PCV), genotypic (GCV) and error (ECV) coefficient of variability for eleven characters were calculated and the results are presented in Table 4.1.10. In general, the phenotypic coefficient of variability (PCV) was greater than the genotypic and error coefficient of variability for all the characters. The estimates of the phenotypic coefficient of variability were the highest for number of grains/cob (788.765) and the lowest PCV was estimated for days to maturity (9.738). The PCVs cob diameter, days to silking and cob diameter were 32.0556, 28.962 and 24.636 (Table 4.1.10.). Genotypic co-efficient of variability was highest for number of grains/cob, while the lowest GCV was estimated for days to maturity.

Error coefficient of variability was high for number of grains/cob followed by grain yield/plant and ear height. However the lowest value of ECV was exhibited by days to maturity (Table 4.1.10.).

(v) Heritability (h^2b), Genetic advance (GA) and Genetic advance in percentage of mean (GA %)

For all the eleven grain yield and yield contributing characters, heritability in broad sense, genetic advance and genetic advance as percentage of mean were calculated separately and the results are shown in the Table 4.1.10.

Heritability (h^2b)

The highest heritability was observed for days to silking (93.406) and this was followed by days to maturity (88.638), days to tasseling (86.033), plant height (81.858), cob length (82.068), ear height (77.795), number of kernels/cob (77.183) and cob diameter (73.646) (Table 4.1.10.). The lowest value of heritability was 66.082 observed for number of grains/cob.

Genetic advance (GA)

The estimation of genetic advance shows the highest value for number of grains/cob (47.624) that was followed by days to silking (37.588), days to tasseling (29.206) and plant height (28.325 cm). The lowest genetic advance was 3.406 estimated for number of rows/cob (Table 4.1.10.).

Genetic advance in percentage of mean (GA %)

The estimation of genetic advance as percentage of mean reveals (Table 4.1.10.) the highest value 55.727 for days to silking and this was followed by number of kernels/row (40.189), days to tasseling (38.599), cob diameter (37.376 cm) and cob length (33.864 cm). The lowest value of GA% was 19.206 found for days to maturity.

Table 4.1.10. Estimation of genetic parameters for grain yields and yield components in maize inbred

Characters	σ^2_g	σ^2_e	σ^2_p	PCV%	ECV%	GCV%	$h^2_b\%$	GA	GA(%) of mean
DT	233.642	37.932	271.574	21.779	8.139	20.201	86.032	29.206	38.599
DS	356.452	25.162	381.615	28.961	7.436	27.99	93.406	37.588	55.727
DM	74.051	30.078	104.13	9.738	5.233	8.212	88.638	23.656	19.206
PH	230.965	51.187	282.153	16.148	6.878	14.61	81.8582	28.325	27.231
EH	180.447	52.918	233.366	32.055	15.105	28.273	77.795	24.491	51.371
CL	3.123	2.294	5.418	20.03	8.482	18.146	82.068	4.763	33.864
CD	7.137	2.554	9.691	24.636	12.647	21.142	73.6465	4.723	37.376
NRC	4.692	2.313	7.006	21.94	11.659	17.956	72.152	3.406	26.059
NKR	20.851	6.164	27.015	19.343	17.137	14.524	77.183	8.264	40.189
NGC	808.787	415.124	$\frac{1223.91}{1}$	788.765	267.532	521.233	66.082	47.624	30.691
GYP	112.393	42.74	155.134	21.477	73.702	18.281	72.4492	18.588	32.054

4.1.2 CORRELATION COEFFICIENT (r)

Correlation coefficients between grain yield and yield attributing characters and correlation coefficients between grain yield attributing characters of 25 maize inbred lines at the genotypic and phenotypic levels were calculated and the results are shown in Tables 4.1.12- 4.1.13.

Genotypic Correlation Coefficient Between Grain Yield with its Components

Genotypic correlation coefficient between grain yield and yield contributing characters is presented in Table 4.1.11. At the genotypic level, grain yield showed highly significant and positive correlation with days to maturity (0.5817*), number of grains/cob (0.6534**) and number of kernels/row

(0.5912**). Cob length showed non significant but negative correlation with grain yield at the genotypic level.

Phenotypic Correlation Coefficient Between Grain Yield with its Components

At the phenotypic level, the grain yield showed significant and positive correlation with days to maturity (0.627**), cob diameter (0.655**), number of kernels/row (0.3458**) and number of grain/cob (0.9372**) (Table 4.1.11).

Table 4.1.11. Genotypic and phenotypic correlation coefficients between grain yield/plant and yield contributing characters in maize

Characters	Correlation coefficient	
	Genotypic	Phenotypic
Days to maturity	0.5817*	0.627**
Plant height	0.208	0.155
Ear height	0.138	0.141
Cob length	-0.023	-0.031
Cob diameter	0.153	0.655**
No. of rows/cob	0.247	0.220
No. of kernels/row	0.591*	0.346*
No. of grains/cob	0.653**	0.937***

Genotypic Correlation Coefficient Between Different Pairs of Characters

Genotypic correlation co-efficient among the different pairs of characters were estimated and the results are presented in Table 4.1.12. Among the different pairs of characters, days to maturity showed highly significant positive correlation with cob diameter, number of kernels/row and grain yield/plant.

On the other hand, genotypic correlation of days to maturity with plant height, ear height, cob length, number of rows/cob and number of grains /cob were non-significant.

Plant height exhibited highly significant and positive correlation with ear height and number of kernels/row. But this character showed non-significant correlation with cob length, cob diameter, number of rows/cob, number of grain/cob and grain yield, respectively. Number of kernels/row showed significant but positive correlation with days to maturity, plant height and cob diameter. On the other hand, this character was non-significant and negative correlation with rest of the characters.

Number of grain/cob showed significant positive correlation with number of row/cob, number of rows/cob and this character showed significant negative correlation with plant height. Genotypic correlation coefficient of days to maturity and number of kernels/row and number grains/cob with grain yield also was positive significant.

Table 4.1.12. Genotypic correlation coefficient (r_g) between different pairs of characters in maize

Characters	PH	EH	CL	CD	NRC	NKR	NGC	GYP
DM	0.229	0.407	-0.442*	0.5412*	0.019	0.524*	-0.196	0.582*
PH	1.000	0.815**	-0.355	0.114	0.879**	0.549*	-0.902**	0.208
EH		1.000	0.618**	-0.634**	-0.902**	0.165	-0.187	0.138
CL			1.000	-0.035	0.016	-0.048	0.097	-0.023
CD				1.000	0.034	0.918**	0.073	0.154
NRC					1.000	0.089	0.718**	0.247
NKR						1.000	0.512*	0.591*
NGC							1.000	0.653**

Phenotypic Correlation Coefficient Between Different Pairs of Characters

Phenotypic correlation co-efficient among different pairs of characters are presented in table 4.1.13.

Among the different inter character associations, days to maturity showed significant positive correlation with cob length, number of rows/cob, number of grains/cob and grain yield.

The associations of days to maturity with other characters were non-significant. Association of plant height with cob length, cob diameter and number of grains/cob were highly significant.

The character, number of kernels/row showed significant positive correlation with cob length and number of rows/cob. Number of rows/cob exhibited non-significant correlation with plant height, ear height, and cob length and cob diameter.

Correlation coefficient of number of grains/cob with number of rows/cob and number of kernels/row were also non-significant. On the other hand, this trait showed non-significant and negative association with ear height and cob length.

The character, grain yield/plant exhibited non-significant and positive correlation with plant height, ear height, number of rows/cob and number of kernels/row.

Days to maturity, cob diameter and number of kernels/cob showed highly significant and positive correlation with grain yield/plant.

Table 4.1.13. Phenotypic correlation coefficient (r_p) between different pairs of characters in maize

Characters	PH	EH	CL	CD	NRC	NKR	NGC	GYP
DM	0.198	0.063	0.564*	0.1799	0.639**	0.145	0.6142*	0.627**
PH	1.000	0.233	0.581*	0.907**	-0.001	0.1734	-0.556*	0.155
EH		1.000	0.193	0.1386	-0.059	0.108	-0.194	0.142
CL			1.000	0.0371	-0.022	-0.652**	-0.040	-0.031
CD				1.0000	-0.005	0.451	0.872**	0.655**
NRC					1.000	0.782**	0.429	0.219
NKR						1.000	0.325	0.346
NGC							1.000	0.937**

4.1.3 PATH COEFFICIENT ANALYSIS

The correlation coefficients between grain yield and yield components were partitioned into direct and indirect effects through path coefficient analysis in order to find out more realistic picture of relationship. Path coefficient analysis was performed using the values of genotypic and phenotypic correlation and are presented in Tables 4.1.14 and 4.1.15, Figures 4.1.1 and 4.1.2.

The results of path coefficient analysis at genotypic and phenotypic levels are described below.

Path Coefficient at Genotypic Level

The results of path coefficient analysis at genotypic level are presented in Table 4.1.14. This table shows that the highest positive direct effect was contributed by number of rows/cob on grain yield and it was followed by number of kernels/row and cob length. Days to maturity, plant height, cob height, cob diameter, number of kernels/cob showed negative direct effect. Number of rows/cob had positive direct effect (0.1814) on grain yield.

However, number of kernels/row, days to maturity, number of grains/cob, number of rows/cob and cob diameter contributed to grain yield through large indirect effects of number of grains/cob (0.6723), number of kernels/row (0.3812), number of grains/cob (0.218) and number of kernels/row (0.1872), respectively. The total effect of cob length on grain yield was 0.4681.

Plant height expressed negative indirect effect on grain yield through number of grains/cob. The character days to maturity showed positive direct effect on grain yield (0.0396). This character showed positive indirect effect on grain yield through cob height, cob length, cob diameter, number of rows/plant and number of grains/cob. On the other hand, plant height had negative indirect effect on grain yield through days to maturity (-0.0829), cob length (-0.0614), cob diameter (-0.0177) and number of grains/cob (-0.1822). The total effect of this character on grain yield was 0.6463.

Ear height had direct negative effect on grain yield (-0.0128). Cob height also contributed to grain yield through positive indirect effect of days to maturity, plant height, cob length, number of kernels/row and number of grains/cob. The indirect effect of cob height through cob diameter and number of rows/cob were negative. The total effect of cob height was 2.3639.

Cob length had positive direct effect (0.0156) on grain yield. It had positive indirect effect through days to maturity, plant height, number of kernels/row and number of grains/cob. The indirect effect of cob length through ear height, cob diameter and number of rows/cob were negative. The total effect of cob length on grain yield was 0.0117.

The character cob diameter showed the negative direct effect (-0.0038) on grain yield. It contributed to grain yield greatly indirect effect through cob length (0.1066) followed by number of kernels/row (0.0753).

The indirect effect of cob diameter through days to maturity, cob length, number of rows/cob and number of kernels/row were positive.

But it showed negative indirect effect via plant height, cob height and number of grains/cob. The total effect of cob diameter was 0.0667.

Number rows/cob showed positive direct effect (0.1814) on grain yield. It showed positive indirect effect through days to maturity, plant height, cob length, cob diameter, and number of grains/cob. But this character exhibited the negative indirect influence on grain yield through cob height and number of kernels/row. The total effect of this trait was 0.3741.

Number of kernels/row had the highest positive direct effect (0.0307) on grain yield. Number of kernels/row had the highest positive indirect effect (0.3923) on grain yield through number of grains/cob followed by days to maturity (0.3812). The total effect of number of kernels/row on grain yield was 0.9364.

Number of grains/cob had the highest negative direct effect (-0.2704) on grain yield. This character had the highest positive indirect effect (0.6723) on grain yield through number of kernels/row followed by number of rows/cob (0.2156). The total effect of this trait was -5.9778.

Table 4.1.14 also shows that the highest total genotypic effect was observed for number of kernels/row (0.9364) and this was followed by number of kernels/cob (0.3741), cob diameter (0.0667). But number of grains/cob exhibited smaller effect of -5.9778.

The considerable amount of residual effect (0.8517) indicated that some other characters which have been included in this study had also effect on grain yield in this crop.

It may be concluded from the present study that number of rows/cob, days to maturity and number of kernels/row are the major components of grain yield in maize inbred lines and hence maximum stress should be given on these characters while selection is done for maximum grain yield.

Table 4.1.14. Path coefficient analysis showing direct and indirect effects of yield components on grain yield/plant of maize at genotypic level

Characters	Grain yield (kernel weight/plant) vs.								r _g with grain yield
	DM	PH	EH	CL	CD	NRC	NKR	NGC	
DM	<u>0.0396</u>	-0.0829	0.0584	0.0017	0.0643	0.0076	0.3812	0.0544	0.5817*
PH	-0.0203	<u>-0.0372</u>	0.0340	0.0066	-0.0130	0.1575	0.1946	-0.5736	0.2076
EH	0.0214	0.0510	<u>-0.0128</u>	-0.0070	-0.1120	-0.0510	0.1918	0.1308	0.1383
CL	-0.0038	-0.0614	0.0433	<u>0.0156</u>	0.1066	0.0750	-0.1624	-0.2229	-0.0223
CD	0.0213	-0.0177	-0.1011	-0.0155	<u>-0.0038</u>	0.1029	0.1872	-5.9840	0.1533
NRC	0.0016	0.1323	-0.0286	-0.0068	0.0639	<u>0.1814</u>	-0.2790	0.2156	0.2471
NKR	-0.0254	0.1059	0.0696	0.0095	0.0753	-0.1808	<u>0.0307</u>	0.6723	0.5912*
NGC	0.0042	-0.1822	0.0277	0.0076	-0.1146	0.0815	0.3923	<u>-0.2704</u>	0.653**
Total Effect	0.0386	-0.0922	0.0905	0.0117	0.0667	0.3741	0.9364	-5.9778	

Residual effect = 0.8517, underlined values denote direct effect.

Path Coefficient at Phenotypic Level

The results of path coefficient analysis at phenotypic level are presented in table 4.1.15. Number of kernels/cob had the highest positive direct effect (2.7688) on grain yield followed by number of kernels/row (0.6409), plant height (0.3518) and number of rows/cob (0.3213).

The highest direct negative effect towards grain yield was found for cob length (-0.0362).

The path analysis revealed that the most of the characters had positive direct effect on grain yield and cob length had negative direct effect on grain yield.

Days to maturity had positive direct effect of 0.0744 on grain weight/plant.

Days to maturity had indirect positive effect (0.222) via cob length followed by

number of rows/cob and number of kernels/row. The indirect effect via plant height, ear height, cob diameter and number of grains/cob was negative.

Plant height had direct positive effect on grain yield. Plant height exhibited the highest indirect positive effect of 0.2851 through number of grains/cob. The indirect effects of plant height on grain yield via days to maturity, ear height, cob length, number of rows/cob and number of kernels/row were negative. The total effect was 0.3042.

The character ear height showed positive direct effect (0.1603) on grain yield. On the other hand, it had indirect positive effect through number of grains/cob. The indirect effects of ear height through most of the characters were negative. The total effect was 0.104.

Cob length indicated the negative direct effect (-0.0362) on grain yield. Cob length showed highest indirect positive effect (0.0062) on grain yield via number of grains/cob. The indirect effects through days to maturity, cob diameter, number of rows/cob, number of kernels/row were negative.

Cob diameter showed the positive direct effect on grain yield. This character showed the highest positive indirect effect (0.0091) through plant height.

However, cob diameter showed negative indirect effects (-0.0130, -0.0056, -0.0085, -0.0004, and -0.0415) through days to maturity, ear height, cob length, number of rows/cob, number of kernels/row but the value was least and negligible.

Number of rows/cob had positive direct effect of 0.03213 on grain yield. The indirect effects of this character on grain yield via plant height, ear height, cob diameter and number of grains/cob were negative. The total effect was 0.013.

Number of kernels/row showed positive direct effect (0.6409) on grain yield. On the other hand, it had indirect positive effect through days to maturity, cob length, and number of rows/cob. The indirect effects of number of kernels/row through most of the characters were negative. The total effect was -0.1732.

The character ear height showed positive direct effect (0.1603) on grain yield. On the other hand, it had indirect positive effect through number of grains/cob. The indirect effects of ear height through most of the characters were negative. The total effect was 0.104.

Number of grains/cob had highest positive direct effect of 2.7688 on grain yield. The indirect effects of this character on grain yield via days to maturity, cob length, number of rows/cob and number of kernels/row were negative. The total effect was 2.2317 (the highest value).

The highest direct positive effect towards grain yield was found for number of grains/cob (2.7688) followed by number of kernels/row (0.6409) and plant height (0.3518). The lowest direct negative effect -0.0362 towards grain yield was found for cob length. The residual effect at phenotypic level was 0.9451.

The path coefficient analysis at phenotypic level in the present study reveals that number of grains/cob had highest total effect (2.2317) on grain yield, which was followed by plant height, ear height and days to maturity with the values of 0.3042, 0.104 and 0.0525, respectively.

Table 4.1.15. Path coefficient analysis showing direct and indirect effects of yield components on grain yield/plant of maize at phenotypic level

Characters	Grain yield (grain weight/plant) vs.								r _p with grain yield
	DM	PH	EH	CL	CD	NRC	NKR	NGC	
DM	<u>0.0744</u>	-0.0520	-0.0110	-0.0110	-0.0130	0.0068	0.0231	-0.1768	0.0627
PH	-0.0210	<u>0.3518</u>	-0.0095	0.0067	0.0091	-0.1558	-0.3311	1.7255	0.1549
EH	-0.0049	-0.0105	<u>0.1603</u>	0.0073	-0.0053	-0.0059	-0.0538	0.2272	0.1407
CL	0.0222	-0.0336	-0.0329	<u>-0.0362</u>	-0.0085	0.0145	0.0709	-0.1855	-0.0311
CD	-0.0125	0.0215	-0.0113	-0.0085	<u>0.0859</u>	-0.0004	-0.2192	0.1386	0.0655
NRC	0.0019	-0.1098	-0.0038	-0.0020	-0.0004	<u>0.3213</u>	0.1342	-1.0784	0.2197
NKR	0.0042	-0.1483	-0.0219	-0.0064	-0.0415	0.0853	<u>0.6409</u>	-1.1877	0.3458
NGC	-0.0118	0.2851	0.0341	0.0062	0.0097	-0.2528	-0.4382	<u>2.7688</u>	0.9372
Total Effect	0.0525	0.3042	0.104	-0.0439	0.036	0.013	-0.1732	2.2317	

Residual effect = 0.9451 Underlined values denote the direct effect.

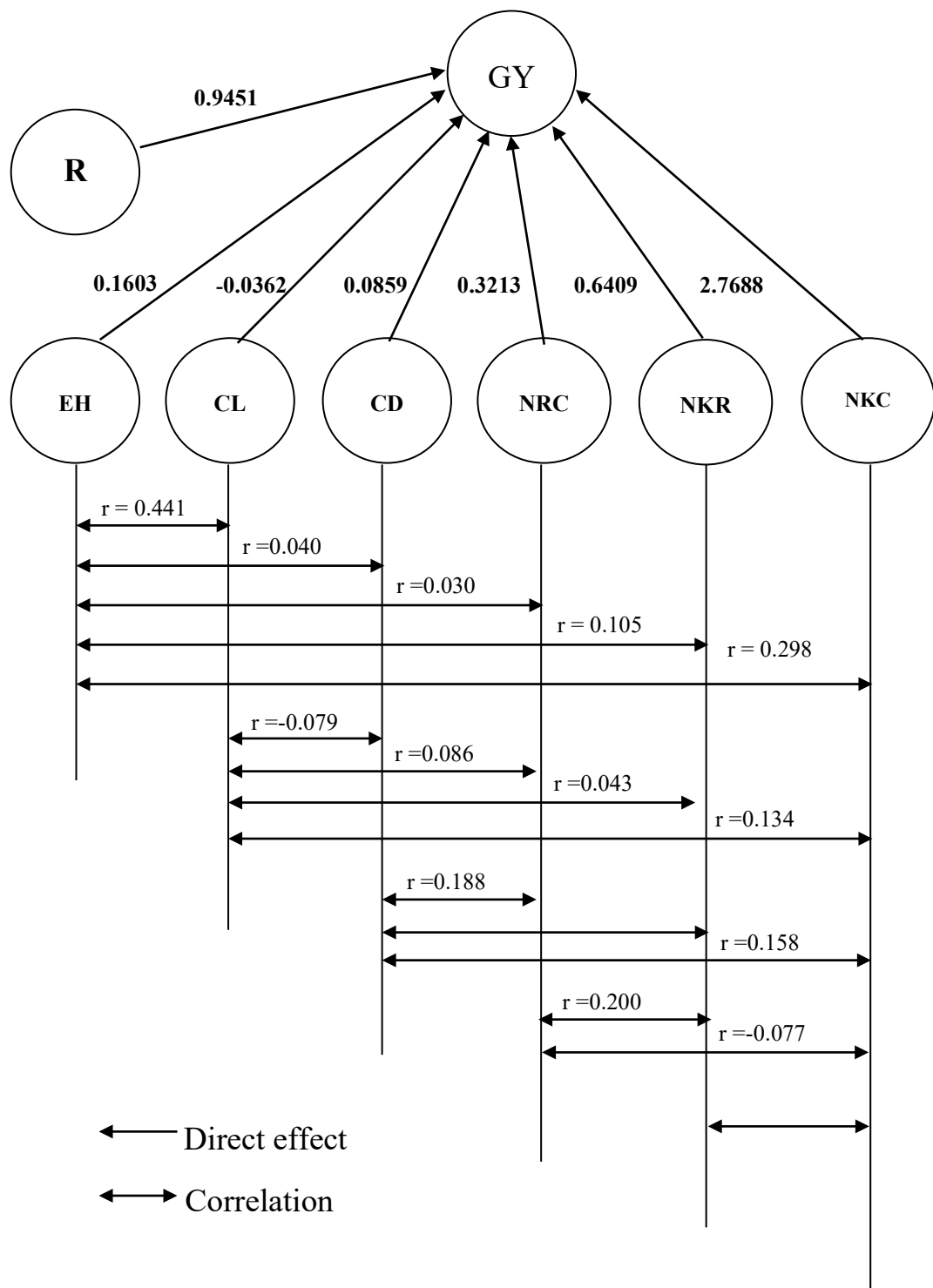

Figure 4.1.1. Path diagram of different grain yield contributing characters on yield at phenotypic level

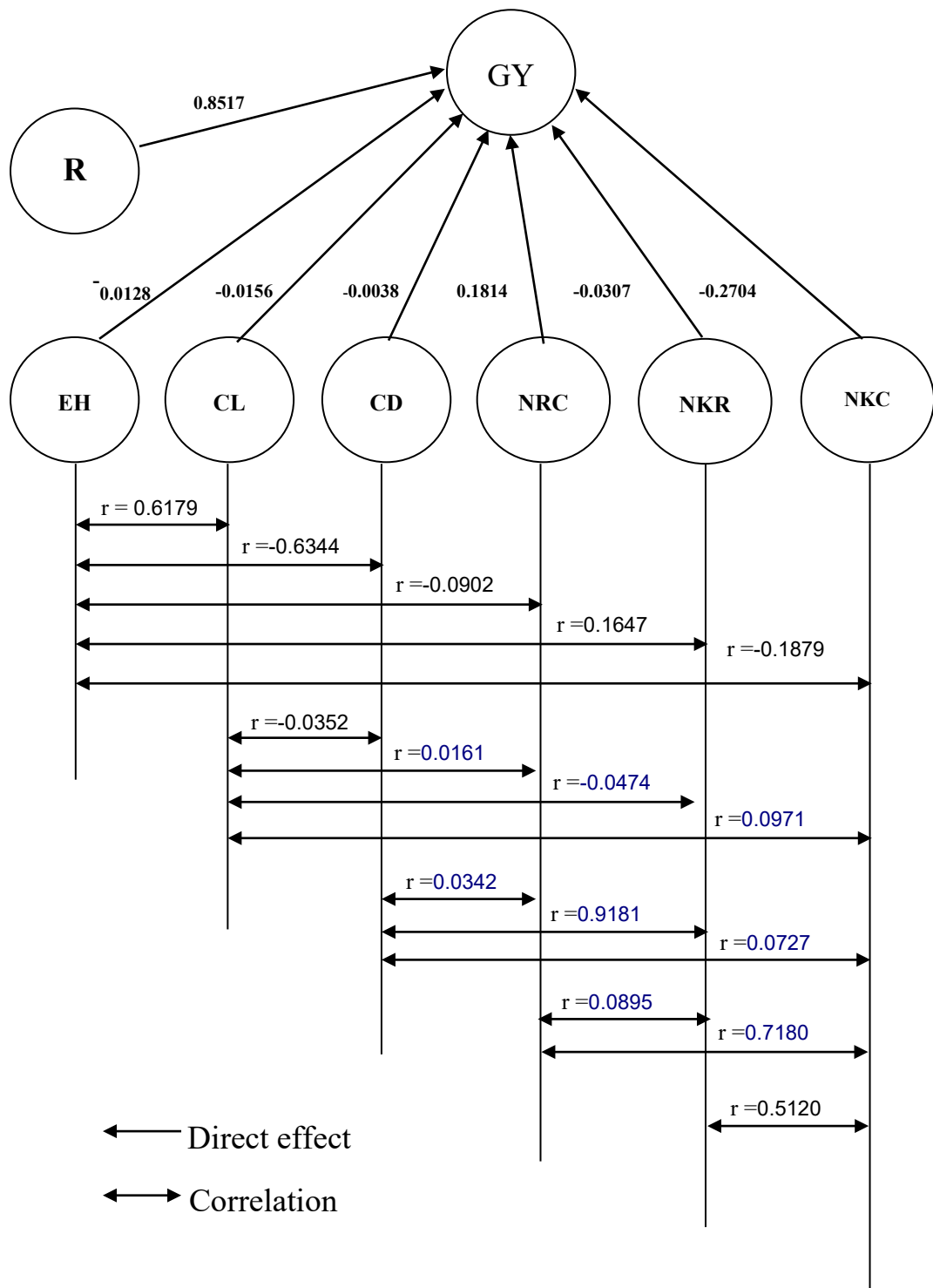

Figure 4.1.2. Path diagram of different grain yield contributing characters on yield at genotypic level

4.1.4 SELECTION INDEX

Selection indices for grain yield were constructed to identify the character or character association over straight selection, which may be useful during selection breeding programme for higher yield. In constructing the selection indices, all the nine quantitative characters *viz*, DM, PH, EH, CL, CD, NRC, NKR, NKC and GYP were included of which GYP was dependent character.

The results obtained for different indices, containing GYP and its components with expected gain in percentage over straight selection are shown in Table 4.1.16. This table showed that the maximum genetic (expected) gain of 192.534% was exhibited when cob height, number of rows/cob, number of kernels/row and grain yield/plant were included in the discriminant function. This value was followed by 158.199% GA which was obtained when cob length, cob diameter, number of row/cob, number of kernels/row and number of grains/cob were included in the discriminant function. In the present investigation, discriminant function analyses have been done considering individual character separately and are shown in Table 4.1.16.

Table 4.1.16 exhibited that individual character expect days to maturity, plant height, cob height and cob diameter showed positive expected gain and among them number of kernels/row exhibited highest genetic gain, followed by number of grain/cob, number of rows/cob and number of kernels/row. Grain yield/plant in combination with two or more characters gave the highest positive expected gain but in the remaining cases it showed negative genetic gain. Number of rows/cob in combination with number of kernels/row (NRC+NKR) gave the highest positive gain of 186.457% followed by 175.429 % (NKR+GYP), 153.913 % (DM+NKR), 122.758 % (DM+CL), 105.593 % (NKR+NGC) and 83.458 (DM+NGC).

In the discriminant function analyses when selection index included three characters, the maximum genetic gain was recorded as 168.975% for

CL+NRC+NKR followed by 159.806% for CL+CD+NKR, 147.618% for DM+CL+NKR.

In the same way, when four characters were included in the discriminant function, GYP in combination with CD, NRC and NKR gave the highest GA% of 162.534% and next were 142.482% and 139.817% and 137.338 by DM+CL+CD+NKR+NGC, DM+PH+CL+NRC+GYP and DM+CL+NRC+NKR, respectively. Similarly, when five characters were included in the discriminant function, GYP in combination with DM, PH, CL and NRC exhibited the highest genetic gain of 139.817%, which was the highest value among all the selection indices followed by 135.467%(CL+CD+NRC+NKR+GYP), 132.804% (DM+PH+CL+NKR+GYP), 131.706 % (DM+PH+CH+CL+GYP) and 125.705 % (DM+CL+NKR+NGP+GYP).

In case of discriminant function when six characters were included, GYP combination with DM, CL, CD, NRC and NRK exhibited the highest genetic gain of 129.328%, followed by 128.498% (EH+CL+CD+NRC+NKR+GYP) and 125.359% (DM+PH+CL+CD+NKR+GYP).

Table 4.1.16 showed the highest value of GA% of 125.0154% when seven characters, such as DM+PH+CL+CD+NRC+NKR+GYP were in combination.

This combination was followed by PH+CL+CD+NRC+NKR+NGC+GYP, DM+PH+EH+CL+NRC+NKR+GYP and DM+PH+EH+CD+NRC+NGC+GYP with the values of 124.113%, 122.015% and 119.584%, respectively.

Similarly, when eight characters were included in the selection index, GYP in combination with DM+PH+EH+CD+NRC+NKR+NGC showed the highest genetic gain of 121.582% and the next were 119.459% and 119.263% for (DM+PH+EH+CL+NRC+NKR+NGC) and (DM+PH+EH+CL+CD+NRC+NKR).

When all the nine quantitative characters were considered the expected genetic gain was found to be 158.723% and this was the second highest in the present discriminant function analysis.

Table 4.1.16. Expected gain in percentage of grain yield over selection from the use of various selection indices in maize inbred lines

Selection index	Expected gain	Selection index	Expected gain	Selection index	Expected gain
X1	-129.809	X5+X6	3.4302	X1+X7+X8	107.6842
X2	-52.9325	X5+X7	-173.994	X1+X7+X9	52.7325
X3	-61.6707	X5+X8	74.989	X1+X8+X9	68.486
X4	31.29928	X5+X9	4.3224	X2+X3+X4	70.442
X5	-41.1064	X6+X7	186.457	X2+X3+X5	69.356
X6	51.52128	X6+X8	-75.516	X2+X3+X6	-69.478
X7	241.5108	X6+X9	8.0630	X2+X3+X7	81.4340
X8	76.337	X7+X8	105.593	X2+X3+X8	80.2636
X9	25.820	X7+X9	175.429	X2+X3+X9	60.0067
X1+X2	70.963	X8+X9	-60.790	X2+X4+X5	-58.044
X1+X3	-79.148	X1+X2+X3	76.8540	X2+X4+X6	-58.092
X1+X4	122.758	X1+X2+X4	72.3973	X2+X4+X7	-83.033
X1+X5	74.8090	X1+X2+X5	70.3667	X2+X4+X8	77.6917
X1+X6	-82.3619	X1+X2+X6	-70.742	X2+X4+X9	45.6736
X1+X7	153.9128	X1+X2+X7	-91.083	X2+X5+X6	56.6788
X1+X8	83.4584	X1+X2+X8	81.4317	X2+X5+X7	73.5281
X1+X9	-31.539	X1+X2+X9	57.0823	X2+X5+X8	76.837
X2+X3	69.1001	X1+X3+X4	-80.002	X2+X5+X9	46.290
X2+X4	-56.6846	X1+X3+X5	-76.0016	X2+X6+X7	-78.972
X2+X5	54.8994	X1+X3+X6	76.9749	X2+X6+X8	94.8053
X2+X6	54.859	X1+X3+X7	117.563	X2+X6+X9	45.6466
X2+X7	82.504	X1+X3+X8	-83.969	X2+X7+X8	84.6101
X2+X8	-77.015	X1+X3+X9	-57.171	X2+X7+X9	-56.053
X2+X9	42.6151	X1+X4+X5	76.3463	X2+X8+X9	-69.128
X3+X4	64.8754	X1+X4+X6	82.2569	X3+X4+X5	-63.482
X3+X5	-60.545	X1+X4+X7	147.618	X3+X4+X6	-64.194
X3+X6	-61.246	X1+X4+X8	83.8938	X3+X4+X7	119.235
X3+X7	-121.665	X1+X4+X9	36.5366	X3+X4+X8	80.2595
X3+X8	79.6717	X1+X5+X6	68.1518	X3+X4+X9	44.7202
X3+X9	-41.325	X1+X5+X7	137.917	X3+X5+X6	61.0801
X4+X5	7.4460	X1+X5+X8	81.7069	X3+X5+X7	106.245
X4+X6	8.8190	X1+X5+X9	-37.5137	X3+X5+X8	-79.036
X4+X7	-204.633	X1+X6+X7	-141.782	X3+X5+X9	-45.323
X4+X8	-77.3202	X1+X6+X8	-82.2772	X3+X6+X7	112.098
X4+X9	9.8926	X1+X6+X9	-36.4947	X3+X6+X8	79.3153

X1=DM, X2=PH, X3=EH, X4= CL, X5= CD,X6= NRC, X7= NKR, X8= NKC and X9= GYP

Table 4.1.16. (Continued)

Selection index	Expected gain	Selection index	Expected gain	Selection index	Expected gain
X3+X6+X9	-44.633	X1+X2+X5+X6	-70.451	X1+X5+X6+X7	128.593
X3+X7+X8	89.049	X1+X2+X5+X7	85.6111	X1+X5+X6+X8	-80.976
X3+X7+X9	56.429	X1+X2+X5+X8	81.0226	X1+X5+X6+X9	-41.450
X3+X8+X9	69.531	X1+X2+X5+X9	-58.889	X1+X5+X7+X8	4.91097
X4+X5+X6	20.389	X1+X2+X6+X7	86.9667	X1+X5+X7+X9	-55.180
X4+X5+X7	159.805	X1+X2+X6+X8	81.2140	X1+X5+X8+X9	-69.225
X4+X5+X8	-75.995	X1+X2+X6+X9	-58.603	X1+X6+X7+X8	98.6625
X4+X5+X9	-6.4526	X1+X2+X7+X8	87.7271	X1+X6+X7+X9	-54.857
X4+X6+X7	168.975	X1+X2+X7+X9	-66.010	X1+X6+X8+X9	-69.146
X4+X6+X8	76.5041	X1+X2+X8+X9	73.6565	X1+X7+X8+X9	-74.563
X4+X6+X9	-3.583	X1+X3+X4+X5	-77.058	X2+X3+X4+X5	-70.595
X4+X7+X8	104.233	X1+X3+X4+X6	77.9722	X2+X3+X4+X6	-70.729
X4+X7+X9	-31.310	X1+X3+X4+X7	-116.167	X2+X3+X4+X7	81.991
X4+X8+X9	-62.261	X1+X3+X4+X8	84.3197	X2+X3+X4+X8	-80.704
X5+X6+X7	147.216	X1+X3+X4+X9	-59.004	X2+X3+X4+X9	-61.415
X5+X6+X8	74.6180	X1+X3+X5+X6	74.9819	X2+X3+X5+X6	-69.797
X5+X6+X9	7.50199	X1+X3+X5+X7	109.622	X2+X3+X5+X7	80.0006
X5+X7+X8	90.2890	X1+X3+X5+X8	-83.145	X2+X3+X5+X8	-80.111
X5+X7+X9	32.4701	X1+X3+X5+X9	-58.997	X2+X3+X5+X9	-61.480
X5+X8+X9	-62.214	X1+X3+X6+X7	112.212	X2+X3+X6+X7	80.4996
X6+X7+X8	92.3308	X1+X3+X6+X8	-83.446	X2+X3+X6+X8	80.2267
X6+X7+X9	-31.167	X1+X3+X6+X9	-58.722	X2+X3+X6+X9	-61.246
X6+X8+X9	62.0051	X1+X3+X7+X8	92.0462	X2+X3+X7+X8	85.290
X7+X8+X9	68.8779	X1+X3+X7+X9	-66.960	X2+X3+X7+X9	-67.322
X1+X2+X3+X4	-77.600	X1+X3+X8+X9	74.1928	X2+X3+X8+X9	-74.223
X1+X2+X3+X5	76.4847	X1+X4+X5+X6	-70.610	X2+X4+X5+X6	-59.426
X1+X2+X3+X6	76.7074	X1+X4+X5+X7	133.944	X2+X4+X5+X7	-78.596
X1+X2+X3+X7	86.2987	X1+X4+X5+X8	-82.220	X2+X4+X5+X8	77.4897
X1+X2+X3+X8	83.2653	X1+X4+X5+X9	-41.540	X2+X4+X5+X9	-48.899
X1+X2+X3+X9	-67.350	X1+X4+X6+X7	137.338	X2+X4+X6+X7	79.8349
X1+X2+X4+X5	71.7317	X1+X4+X6+X8	-82.766	X2+X4+X6+X8	-77.647
X1+X2+X4+X6	72.1065	X1+X4+X6+X9	-40.697	X2+X4+X6+X9	-48.341
X1+X2+X4+X7	90.8431	X1+X4+X7+X8	106.930	X2+X4+X7+X8	84.9401
X1+X2+X4+X8	81.8660	X1+X4+X7+X9	-55.460	X2+X4+X7+X9	-58.021
X1+X2+X4+X9	-58.813	X1+X4+X8+X9	69.4410	X2+X4+X8+X9	69.9424

Table 4.1.16. (Continued)

Selection index	Expected gain	Selection index	Expected gain	Selection index	Expected gain
X2+X5+X6+X7	76.0454	X4+X5+X8+X9	-63.540	X1+X2+X5+X6+X7	80.889
X2+X5+X6+X8	76.889	X4+X6+X7+X8	92.0625	X1+X2+X5+X6+X8	139.76
X2+X5+X6+X9	-48.844	X4+X6+X7+X9	-36.629	X1+X2+X5+X6+X9	86.643
X2+X5+X7+X8	83.6136	X4+X6+X8+X9	-63.357	X1+X2+X5+X7+X8	133.068
X2+X5+X7+X9	-58.017	X4+X7+X8+X9	-69.891	X1+X2+X5+X7+X9	125.919
X2+X5+X8+X9	-69.840	X5+X6+X7+X8	87.428	X1+X2+X5+X8+X9	86.996
X2+X6+X7+X8	83.9615	X5+X6+X7+X9	192.534	X1+X2+X6+X7+X8	133.166
X2+X6+X7+X9	-57.722	X5+X6+X8+X9	136.693	X1+X2+X6+X7+X9	125.958
X2+X6+X8+X9	-69.747	X5+X7+X8+X9	130.451	X1+X2+X6+X8+X9	122.390
X2+X7+X8+X9	73.9894	X6+X7+X8+X9	130.501	X1+X2+X7+X8+X9	76.0556
X3+X4+X5+X6	-63.716	X1+X2+X3+X4+X5	77.2097	X1+X3+X4+X5+X6	108.462
X3+X4+X5+X7	-103.379	X1+X2+X3+X4+X6	77.431	X1+X3+X4+X5+X7	83.5154
X3+X4+X5+X8	79.6256	X1+X2+X3+X4+X7	86.561	X1+X3+X4+X5+X8	139.375
X3+X4+X5+X9	-48.184	X1+X2+X3+X4+X8	83.578	X1+X3+X4+X5+X9	111.039
X3+X4+X6+X7	110.132	X1+X2+X3+X4+X9	131.706	X1+X3+X4+X6+X7	83.808
X3+X4+X6+X8	-79.898	X1+X2+X3+X5+X6	76.459	X1+X3+X4+X6+X8	139.612
X3+X4+X6+X9	-47.598	X1+X2+X3+X5+X7	84.678	X1+X3+X4+X6+X9	92.031
X3+X4+X7+X8	89.1700	X1+X2+X3+X5+X8	82.991	X1+X3+X4+X7+X8	131.833
X3+X4+X7+X9	-58.512	X1+X2+X3+X5+X9	131.809	X1+X3+X4+X7+X9	-125.209
X3+X4+X8+X9	70.3641	X1+X2+X3+X6+X7	85.190	X1+X3+X4+X8+X9	95.869
X3+X5+X6+X7	87.7470	X1+X2+X3+X6+X8	83.124	X1+X3+X5+X6+X7	-82.781
X3+X5+X6+X8	-78.837	X1+X2+X3+X6+X9	131.922	X1+X3+X5+X6+X8	139.632
X3+X5+X6+X9	-48.083	X1+X2+X3+X7+X8	87.585	X1+X3+X5+X6+X9	89.903
X3+X5+X7+X8	87.0188	X1+X2+X3+X7+X9	127.098	X1+X3+X5+X7+X8	132.240
X3+X5+X7+X9	-58.367	X1+X2+X3+X8+X9	122.652	X1+X3+X5+X7+X9	125.430
X3+X5+X8+X9	-70.208	X1+X2+X4+X5+X6	71.736	X1+X3+X5+X8+X9	-90.511
X3+X6+X7+X8	87.6214	X1+X2+X4+X5+X7	85.912	X1+X3+X6+X7+X8	132.299
X3+X6+X7+X9	-58.098	X1+X2+X4+X5+X8	81.455	X1+X3+X6+X7+X9	125.453
X3+X6+X8+X9	-70.129	X1+X2+X4+X5+X9	139.566	X1+X3+X6+X8+X9	121.611
X3+X7+X8+X9	74.713	X1+X2+X4+X6+X7	87.163	X1+X3+X7+X8+X9	125.705
X4+X5+X6+X7	139.289	X1+X2+X4+X6+X8	81.643	X1+X4+X5+X6+X7	-81.509
X4+X5+X6+X8	-75.597	X1+X2+X4+X6+X9	139.817	X1+X4+X5+X6+X8	155.091
X4+X5+X6+X9	-15.860	X1+X2+X4+X7+X8	87.915	X1+X4+X5+X6+X9	-94.524
X4+X5+X7+X8	90.241	X1+X2+X4+X7+X9	132.804	X1+X4+X5+X7+X8	142.481
X4+X5+X7+X9	-37.660	X1+X2+X4+X8+X9	125.750	X1+X4+X5+X7+X9	-129.891

Table 4.1.16. (Continued)

Selection index	Expected gain	Selection index	Expected gain	Selection index	Expected gain
X1+X4+X5+X8+X9	-97.224	X2+X4+X5+X8+X9	-84.3102	X1+X2+X3+X4+X6+X8	131.037
X1+X4+X6+X7+X8	142.736	X2+X4+X6+X7+X8	-140.498	X1+X2+X3+X4+X6+X9	-87.764
X1+X4+X6+X7+X9	129.958	X2+X4+X6+X7+X9	-129.484	X1+X2+X3+X4+X7+X8	126.399
X1+X4+X6+X8+X9	124.759	X2+X4+X6+X8+X9	-125.393	X1+X2+X3+X4+X7+X9	122.238
X1+X4+X7+X8+X9	91.493	X2+X4+X7+X8+X9	-83.163	X1+X2+X3+X4+X8+X9	-83.937
X1+X5+X6+X7+X8	142.996	X2+X5+X6+X7+X8	140.516	X1+X2+X3+X5+X6+X7	-82.897
X1+X5+X6+X7+X9	130.159	X2+X5+X6+X7+X9	-129.58	X1+X2+X3+X5+X6+X8	131.135
X1+X5+X6+X8+X9	125.175	X2+X5+X6+X8+X9	-125.628	X1+X2+X3+X5+X6+X9	-86.961
X1+X5+X7+X8+X9	125.150	X2+X5+X7+X8+X9	125.650	X1+X2+X3+X5+X7+X8	126.668
X1+X6+X7+X8+X9	-70.953	X2+X6+X7+X8+X9	-87.727	X1+X2+X3+X5+X7+X9	122.403
X2+X3+X4+X5+X6	80.609	X3+X4+X5+X6+X7	-79.414	X1+X2+X3+X5+X8+X9	-87.180
X2+X3+X4+X5+X7	80.541	X3+X4+X5+X6+X8	149.386	X1+X2+X3+X6+X7+X8	126.692
X2+X3+X4+X5+X8	137.244	X3+X4+X5+X6+X9	-87.242	X1+X2+X3+X6+X7+X9	122.415
X2+X3+X4+X5+X9	-81.088	X3+X4+X5+X7+X8	-139.803	X1+X2+X3+X6+X8+X9	119.683
X2+X3+X4+X6+X7	-80.657	X3+X4+X5+X7+X9	129.015	X1+X2+X3+X7+X8+X9	-84.064
X2+X3+X4+X6+X8	137.454	X3+X4+X5+X8+X9	-87.817	X1+X2+X4+X5+X6+X7	-81.314
X2+X3+X4+X6+X9	85.554	X3+X4+X6+X7+X8	140.026	X1+X2+X4+X5+X6+X8	138.343
X2+X3+X4+X7+X8	131.664	X3+X4+X6+X7+X9	-129.085	X1+X2+X4+X5+X6+X9	-86.868
X2+X3+X4+X7+X9	125.238	X3+X4+X6+X8+X9	-124.669	X1+X2+X4+X5+X7+X8	131.982
X2+X3+X4+X8+X9	-79.440	X3+X4+X7+X8+X9	-86.074	X1+X2+X4+X5+X7+X9	125.358
X2+X3+X5+X6+X7	-80.116	X3+X5+X6+X7+X8	140.168	X1+X2+X4+X5+X8+X9	-87.210
X2+X3+X5+X6+X8	137.403	X3+X5+X6+X7+X9	-124.977	X1+X2+X4+X6+X7+X8	132.064
X2+X3+X5+X6+X9	-84.725	X3+X5+X7+X8+X9	-124.976	X1+X2+X4+X6+X7+X9	125.391
X2+X3+X5+X7+X8	131.844	X3+X6+X7+X8+X9	-87.618	X1+X2+X4+X6+X8+X9	121.933
X2+X3+X5+X7+X9	125.370	X4+X5+X6+X7+X8	-158.199	X1+X2+X4+X7+X8+X9	-86.108
X2+X3+X5+X8+X9	-84.938	X4+X5+X6+X7+X9	135.467	X1+X2+X5+X6+X7+X8	132.306
X2+X3+X6+X7+X8	-131.944	X4+X5+X6+X8+X9	-129.515	X1+X2+X5+X6+X7+X9	125.551
X2+X3+X6+X7+X9	125.412	X4+X5+X7+X8+X9	-129.552	X1+X2+X5+X6+X8+X9	122.204
X2+X3+X6+X8+X9	-122.275	X4+X6+X7+X8+X9	129.865	X1+X2+X5+X7+X8+X9	122.190
X2+X3+X7+X8+X9	-77.084	X5+X6+X7+X8+X9	-77.158	X1+X2+X6+X7+X8+X9	-94.904
X2+X4+X5+X6+X7	-77.517	X1+X2+X3+X4+X5+X6	-85.012	X1+X3+X4+X5+X6+X7	-83.155
X2+X4+X5+X6+X8	148.824	X1+X2+X3+X4+X5+X7	-83.302	X1+X3+X4+X5+X6+X8	138.144
X2+X4+X5+X6+X9	-83.973	X1+X2+X3+X4+X5+X8	130.937	X1+X3+X4+X5+X6+X9	-90.002
X2+X4+X5+X7+X8	140.244	X1+X2+X3+X4+X5+X9	-85.503	X1+X3+X4+X5+X7+X8	131.136
X2+X4+X5+X7+X9	-129.400	X1+X2+X3+X4+X6+X7	-83.434	X1+X3+X4+X5+X7+X9	124.865

Table 4.1.16. (Continued)

Selection index	Expected gain	Selection index	Expected gain	Selection index	Expected gain
X1+X3+X4+X5+X8+X9	-90.582	X2+X4+X6+X7+X8+X9	125.281	X1+X3+X5+X6+X7+X8+X9	-75.723
X1+X3+X4+X6+X7+X8	131.178	X2+X5+X6+X7+X8+X9	-86.336	X1+X4+X5+X6+X7+X8+X9	-84.739
X1+X3+X4+X6+X7+X9	124.882	X3+X4+X5+X6+X7+X8	138.507	X2+X3+X4+X5+X6+X7+X8	130.285
X1+X3+X4+X6+X8+X9	121.161	X3+X4+X5+X6+X7+X9	128.498	X2+X3+X4+X5+X6+X7+X9	-121.657
X1+X3+X4+X7+X8+X9	-88.889	X3+X4+X5+X6+X8+X9	-124.393	X2+X3+X4+X5+X7+X8+X9	-121.653
X1+X3+X5+X6+X7+X8	131.546	X3+X4+X5+X7+X8+X9	-124.387	X2+X3+X4+X6+X7+X8+X9	-121.854
X1+X3+X5+X6+X7+X9	125.090	X3+X4+X6+X7+X8+X9	-124.672	X2+X3+X5+X6+X7+X8+X9	-75.2753
X1+X3+X5+X6+X8+X9	121.498	X3+X5+X6+X7+X8+X9	128.986	X2+X4+X5+X6+X7+X8+X9	124.113
X1+X3+X5+X7+X8+X9	121.463	X4+X5+X6+X7+X8+X9	-84.295	X3+X4+X5+X6+X7+X8+X9	-86.844
X1+X3+X6+X7+X8+X9	-91.459	X1+X2+X3+X4+X5+X6+X7	-83.204	X1+X2+X3+X4+X5+X6+X7+X8	125.653
X1+X4+X5+X6+X7+X8	140.908	X1+X2+X3+X4+X5+X6+X8	130.314	X1+X2+X3+X4+X5+X6+X7+X9	119.263
X1+X4+X5+X6+X7+X9	129.328	X1+X2+X3+X4+X5+X6+X9	-87.154	X1+X2+X3+X4+X5+X7+X8+X9	119.240
X1+X4+X5+X6+X8+X9	124.535	X1+X2+X3+X4+X5+X7+X8	126.012	X1+X2+X3+X4+X6+X7+X8+X9	119.459
X1+X4+X5+X7+X8+X9	124.505	X1+X2+X3+X4+X5+X7+X9	-122.007	X1+X2+X3+X5+X6+X7+X8+X9	121.581
X1+X4+X6+X7+X8+X9	124.887	X1+X2+X3+X4+X5+X8+X9	-87.368	X1+X2+X4+X5+X6+X7+X8+X9	-120.925
X1+X5+X6+X7+X8+X9	-80.054	X1+X2+X3+X4+X6+X7+X8	126.029	X1+X3+X4+X5+X6+X7+X8+X9	-121.461
X2+X3+X4+X5+X6+X7	-80.535	X1+X2+X3+X4+X6+X7+X9	122.015	X2+X3+X4+X5+X6+X7+X8+X9	-119.148
X2+X3+X4+X5+X6+X8	136.221	X1+X2+X3+X4+X6+X8+X9	-119.352	X1+X2+X3+X4+X5+X6+X7+X8+X9	158.723
X2+X3+X4+X5+X6+X9	-84.999	X1+X2+X3+X4+X7+X8+X9	-86.646		
X2+X3+X4+X5+X7+X8	130.909	X1+X2+X3+X5+X6+X7+X8	126.277		
X2+X3+X4+X5+X7+X9	124.861	X1+X2+X3+X5+X6+X7+X9	-122.172		
X2+X3+X4+X5+X8+X9	-85.208	X1+X2+X3+X5+X6+X8+X9	119.583		
X2+X3+X4+X6+X7+X8	130.994	X1+X2+X3+X5+X7+X8+X9	119.562		
X2+X3+X4+X6+X7+X9	124.897	X1+X2+X3+X6+X7+X8+X9	-86.348		
X2+X3+X4+X6+X8+X9	121.850	X1+X2+X4+X5+X6+X7+X8	-68.705		
X2+X3+X4+X7+X8+X9	-84.463	X1+X2+X4+X5+X6+X7+X9	125.015		
X2+X3+X5+X6+X7+X8	131.163	X1+X2+X4+X5+X6+X8+X9	-121.767		
X2+X3+X5+X6+X7+X9	125.023	X1+X2+X4+X5+X7+X8+X9	-121.750		
X2+X3+X5+X6+X8+X9	122.064	X1+X2+X4+X6+X7+X8+X9	-122.003		
X2+X3+X5+X7+X8+X9	122.063	X1+X2+X5+X6+X7+X8+X9	-93.413		
X2+X3+X6+X7+X8+X9	-83.530	X1+X3+X4+X5+X6+X7+X8	130.517		
X2+X4+X5+X6+X7+X8	138.933	X1+X3+X4+X5+X6+X7+X9	-75.450		
X2+X4+X5+X6+X7+X9	-128.866	X1+X3+X4+X5+X6+X8+X9	-78.932		
X2+X4+X5+X6+X8+X9	-125.04	X1+X3+X4+X5+X7+X8+X9	-78.971		
X2+X4+X5+X7+X8+X9	-125.067	X1+X3+X4+X6+X7+X8+X9	-78.657		

4.1.5 GENETIC DIVERGENCE ANALYSIS

In order to find out the extent of genetic diversity among the 25 inbred lines cluster, variate and vector analyses were performed for different characters. The results of these analyses are described below.

Cluster Analysis

By application of non-hierarchical clustering using co-variance matrix, 25 lines were grouped into five different clusters. Compositions of different clusters with their corresponding inbred lines in each cluster are presented in Table 4.1.17. It is revealed from Table 4.1.17 that clusters I, II and IV had the maximum number of lines and cluster III had the minimum number.

Cluster III had three inbred lines *viz.*, IL-2, IL-4 and IL-22. Cluster V consisted of four inbred lines *viz.*, IL-11, IL-17, IL-21 and IL-22. Cluster I had six inbred lines which were IL-1, IL-3, IL-5, IL-7, IL-8 and IL-12. Cluster II also comprised six inbred lines, which were IL-6, IL-9, IL-17, IL-18, IL-21 and IL-25. Six inbred lines *viz.*, IL-10, IL-13, IL-14, IL-15, IL-16 and IL-20 were found in cluster IV.

Canonical Variate Analysis

Canonical variate analysis was done to calculate intra-cluster Mahalanobis's values. The intra and inter-cluster distance (D^2) values are presented in Table 4.1.18. Inbred lines grouped in the intra-cluster are expected to be genetically more similar to each other while inbred lines grouped in inter clusters as genetically more divergent. Intra-group distances appeared much smaller than inter-group, suggesting a lower genetic diversity among the lines of the same group than those from different groups. The intra-cluster divergence among the inbred lines under different clusters varied from 0.252 to 1.642. The highest intra-cluster distance was observed among the lines in cluster III; whereas, it was minimum in cluster V. The intra-cluster distance of clusters I, II and IV was 0.492, 0.683 and 0.871, respectively. Inter-cluster distances ranged from 3.766 to 19.279.

The maximum inter-cluster distance was observed between clusters I and II (19.279) indicating that the inbred lines grouped in these clusters were highly divergent from each other. On the other hand, the distance between clusters I and V was 18.844 and between II and III, I and IV and III and V were approximately same values. The lowest inter-cluster distance was observed between the clusters II and IV (3.766).

Cluster Means

The genetic differences between clusters were reflected in their cluster means. Mean values for different clusters are presented in Table 4.1.19. The highest mean values for days to tasseling and silking, days to maturity, ear length and grain yield/plant were observed in the cluster V. On the other hand, in cluster V the highest values were recorded for days to maturity, grain yield/plant and days to tasseling. Number of kernels/ear, plant height, days to maturity, grain yield/plant and days to silking showed the highest cluster means in clusters IV, V, II, and I (Table 4.1.19).

Contribution of Characters towards Divergence of the inbred lines

Contribution of characters towards divergence is presented in Table 4.1.20. Results showed that, Vector I obtained from principal component analysis expressed that the important characters responsible for genetic divergence in the major axis of differentiation were days to silking, ear height, cob diameter and number of kernels/ear. In vector II, which is the second axis of differentiation, the responsible characters were ear diameter and number of kernel rows/ear, played their major role on genetic divergence. Days to tasseling, plant height, cob length, cob diameter, number of kernels/ear and kernel yield showed positive values in respect to both the vectors were the major important traits responsible for genetic divergence in the major axis of differentiation. So, the greater divergence in the present materials due to these six characters will offer a good scope for improvement of yield through selection of parents.

Table 4.1.17. Distribution of 25 maize inbred lines in five different clusters

Group/Cluster no.	No. of inbred lines	Inbred lines in different clusters
I	6	IL1, IL3, IL5, IL7, IL8, IL12
II	6	IL6, IL9, IL17, IL18, IL21, IL25
III	3	IL2, IL4, IL22
IV	6	IL10, IL13, IL14, IL15, IL16, IL20
V	4	IL11, IL17, IL21, IL22
Total=25		

Table 4.1.18. Inter and intra-cluster (bold) distance (D^2) for 25 maize inbred lines obtained by canonical variate analysis

Clusters	I	II	III	IV	V
I	0.492				
II	19.279	0.683			
III	8.097	11.205	1.642		
IV	11.627	7.741	3.766	0.871	
V	18.844	3.986	11.232	7.468	0.252

**Figure 4.1.3. Diagram showing intra and inter-cluster distance of 30 maize inbred lines**

Table 4.1.19. Cluster means for 11 characters of 25 maize inbred lines

Characters	Clusters				
	I	II	III	IV	V
Days to tasseling	64.75	65.55	64.67	65.41	65.88
Days to silking	66.73	65.80	64.89	66.21	66.18
Days to maturity	102.40	105.55	101.89	102.31	103.51
Plant height	114.40	119.15	105.85	109.55	102.25
Ear height	45.39	49.91	43.84	47.96	49.75
Cob length	12.08	13.50	10.93	13.70	11.76
Cob diameter	11.20	10.85	12.10	11.50	11.25
No. of kernel rows/cob	13.75	12.85	12.15	11.90	12.25
No. of kernels/row	23.55	21.85	23.31	20.50	19.90
No. of kernels/cob	261.56	193.25	230.00	275.70	198.65
Grain yield/plant(GYP)	73.23	70.08	71.51	75.14	80.62

Table 4.1.20. Relative contributions of 11 characters to the total divergence in maize

Characters	Vector I	Vector II
Days to tasseling	0.1511	0.1426
Days to silking	0.4569	-0.8246
Days to maturity	-0.3794	-0.2930
Plant height	0.0888	0.0997
Ear height	0.4263	-0.0549
Cob length	0.4260	0.6849
Cob diameter	0.8342	2.6272
No. of kernel rows/cob	-0.0093	0.5307
No. of kernels/row	-0.9731	-1.1659
No. of kernels/cob	0.2166	0.0030
Grain yield/plant(GYP)	0.1445	0.1480

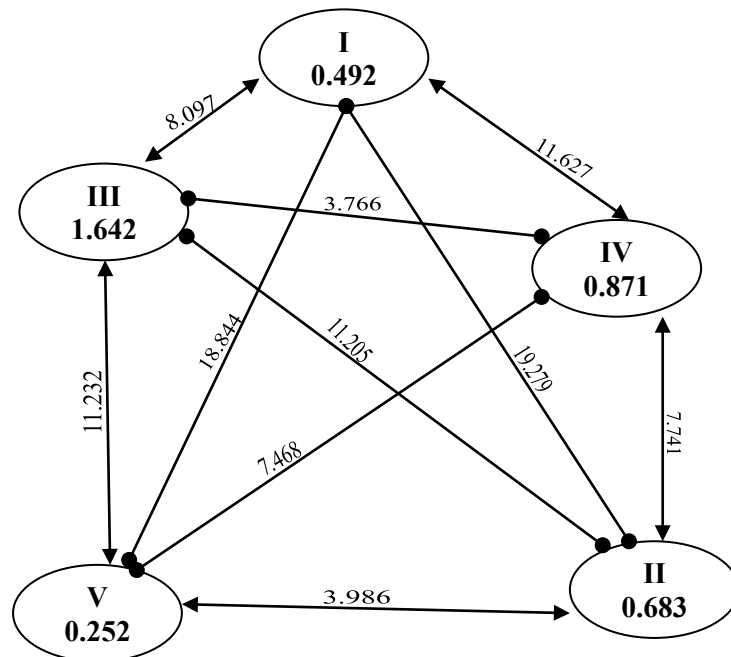
EXPERIMENT II (6×6 DIALLEL CROSS)

4.2.1 DIALLEL ANALYSIS

Mean Performance of F₁ Hybrids Involving 25 Inbred Lines

Statistically significant variation was observed among all the crosses. From Table 4.2.1, it is observed that a number F₁ yielded higher than selfing. The maximum yield was obtained from the F₁s P₁×P₅, P₅×P₆ and P₃×P₅ followed by P₄×P₆. The minimum yield was recorded from P₂×P₅ followed by P₂×P₄. Among the F₁s, P₁×P₂ followed by P₁×P₃ and P₁×P₅ showed identical and took maximum days to tasseling. The shorter time to tasseling was found for P₃×P₄ followed by P₂×P₆ and P₂×P₃. Regarding days to silking a wide range of variation (92.50-100.25) was observed for the trait. The F₁s P₁×P₂, P₁×P₅ and P₁×P₃ took identical and took the maximum time. The early maturing F₁ was P₃×P₅, which was statistically identical with P₂×P₅ and P₃×P₄ followed by P₂×P₄. A range from 121.62-160.10cm was observed for plant height. Among the F₁s produced significantly highest plant height followed by P₂×P₃, P₄×P₆ and P₃×P₄. The shortest plant height was recorded from P₃×P₅. In case of ear height a range of 54.92-75.76 cm was found among the F₁s. P₂×P₃ produced significantly highest ear height followed by P₂×P₄. The lowest ear height was found for P₁×P₅. The highest cob length was recorded in P₂×P₆ followed by P₂×P₅, P₁×P₄ and P₁×P₃. P₁×P₆ produced the shortest cob length. The maximum cob diameter was found in P₄×P₅, P₁×P₃, P₂×P₃ and P₁×P₅ and minimum was produced by P₃×P₅. Regarding number of rows/cob, hybrids P₁×P₂, P₁×P₃ and P₂×P₃ produced maximum number which was significant. P₂×P₅ gave the minimum number. P₁×P₃ produced significantly the highest number of kernels/row and minimum number was in P₂×P₄. The highest number of grains/cob was obtained from P₂×P₃ followed by P₁×P₂, P₁×P₃ and P₅×P₆. Now based on yield and desired quantitative characters F₁ hybrids P₁×P₅, P₅×P₆, P₄×P₅, P₃×P₅ and P₄×P₆ are considered as better performer.

Testing the Validity of the Hypothesis

The validity of the postulated hypothesis for diallel was tested by t^2 and the obtained values were 0.076, 0.52, 0.0028, 0.002, 0.224 and 0.0212, respectively for characters days to tasselling, days to silking, plant height, number of rows/cob, ear height and cob length. The values suggested the probable fulfilment of the postulated hypothesis.

Genetic Components of Variation and Their Proportions

Estimates of genetic components of variation and their proportion are presented in Tables 4.2.2-4.2.12. The sign of component F indicates the relative frequencies of dominance and recessive alleles in the parents. In the present study value of F for all the characters except cob diameter were positive and greater than zero, which expressed that dominant alleles were more frequent than recessive alleles. The estimate of additive genetic variance (D) was significant for days to silking, days to maturity, ear height and number of kernel rows/ear indicating the importance of additive gene effect in their inheritance. The component H_1 which measures the dominance variation was highly significant for all the characters which indicate the dominance gene effect in the inheritance of these characters. The component H_2 was highly significant for all the characters indicating the dominance with asymmetry of positive and negative gene effect in controlling these characters. Thus highly significant values of the components D, H_1 and H_2 indicated the importance of both additive and dominant gene effect for the characters under study. The magnitude of H_1 was greater than D indicating the predominance of dominance effect over additive effect for expression of the characters. The value of h^2 which measures the dominant effect over all loci was non-significant for all the characters. The magnitude of E (environmental variance) for each character was much lower than the respective value of D and H_1 .

This indicated that the environment had lesser effect on the characters than the additive and dominant effects. The average degree of dominance $(H_1/D)^{1/2}$ was more than unity for all the characters suggesting the importance of over dominance for these traits.

The proportion (ratio) of $H_2/4H_1$ provides an estimate of the average frequency of positive and negative alleles in the parents. The values of this ratio were smaller than 0.25 for all the characters which indicated that positive and negative alleles were not distributed in equal proportion in the parents. However, the values of this ratio were near 0.25 for cob diameter which indicated that positive and negative alleles were distributed nearly in equal proportion for the trait. The ratio of $[4DH_1]^{1/2} + F/[4DH_1]^{1/2} - F$ estimates the relative proportion of dominant and recessive alleles in the parents. In the present investigation the values of this ratio were greater than unity in all the characters except cob diameter, suggesting excess of dominant alleles and minority of recessive alleles i.e., asymmetrical distribution of dominant and recessive alleles in the parents for the characters. Another ratio h^2/H_2 provides an estimate the number of groups of genes that control a character and exhibit degree of dominance to some extent. If the dominance effect of the genes differs in size or sign, the ratio would be underestimated. Also it does not provide any information about genes exhibiting little or no dominance. The values of the ratio were greater than one indicating many groups of genes were responsible for their genetical control.

Graphical Analysis (Wr-Vr graph)

Wr-Vr graphs, the two directional depictions were made based on the parent-offspring co-variance (W_r) and parental variance (V_r) is presented in Figures 4.2.1 to 4.2.11. By plotting the paired of values of V_r and W_r the position of arrays was obtained in the W_r/V_r graphs. The position of the dominant homozygote on the regression line will be near to the origin as compared to that of the recessive homozygote.

Thus, the positions of the parents on the line will indicate the direction of dominance. In the absence of dominance, both the parental points will cluster together and will thus make a single point.

The analysis of variance due to diallel progenies indicated significant differences among themselves (Table 4.2.13), which warrants for further analysis. Hayman's graphic approach to diallel analysis is based on monogenic additive model.

Hence testing the adequacy of the model is important to detect the presence or absence of epistasis. Different assumptions underlying the diallel cross analysis were tested by t^2 (test of homogeneity of W_r - V_r variances). The t^2 values for all the characters studied were insignificant indicated the validity of the hypothesis i.e., the basic assumption (including the absence of epistasis) made for the simple additive-dominance model was satisfied for all the traits studied.

Days to tasseling: The observed regression line intercepted the W_r axis above the point of origin showing partial dominance gene action in the expression of the character. The scattered distribution of array points indicated the diversity existed among the parents. It is clear from the graph that the array points representing their respective parental number are clustered into three major groups along the regression line.

Days to silking: The observed regression line passed through the W_r axis above the point of origin showing over dominance. Wide distribution of array points in the V_r - W_r graph showed genetic diversity among the parents. It is clear from the graph that the array points representing their respective parental number are clustered into two major groups along the regression line.

Days to maturity: The observed regression line intercepted the W_r axis above the point of origin showing partial dominance gene action in the expression of the character. The striking discontinuity between array points indicated that there was a wide genetic diversity between and within the parental groups.

The parent P_2 had maximum concentration of dominant genes due to their proximity to the points of origin whereas P_3 far away from the origin carried maximum number of recessive genes.

Plant height: W_r - V_r graph for plant height is presented in Figure 4.2.4. The graph showed that the regression line passed just through the point of origin which indicated the presence of an average complete dominance over all arrays

Ear height: Regression line intercepted Y axis above the point of origin indicating partial dominance. The striking discontinuity among the array points representing their respective parental number indicated that there was a wide genetic diversity between and within the parents. Parent P_6 had maximum concentration of dominant genes due to its proximity to the points of origin whereas the parent P_3 being away from the origin carried maximum number of recessive genes. The other parents scattered along the regression line of the graph contained equal frequencies of dominant and recessive alleles.

Cob length: The observed regression line intercepted the W_r axis above the point of origin showing partial dominance gene action in the expression of the character. The striking discontinuity between the array points indicated that there was a wide genetic diversity between and within the parental groups.

Cob diameter: For cob diameter, the observed regression line passed through the W_r axis above the point of origin showing partial dominance. Wide distribution of array points in the W_r - V_r graph showed genetic diversity among the parents. It is clear from the graph that the array points representing their respective parental number are clustered into three major groups along the regression line. In the first group parent P_2 and four parents had maximum concentration of dominant genes due to their proximity to the points of origin.

Number of rows/cob: For number of rows per cob, the observed regression line passed through the W_r axis above the point of origin showing partial dominance. Wide distribution of array points in the W_r - V_r graph showed genetic diversity among the parents. Parent P_6 had maximum concentration of

dominant genes due to its position nearest to the point of origin and parent P₃ fall furthest away from the origin carried maximum number of recessive genes containing the character. All other parents lying scattered along the regression line of the graph contained equal frequencies of dominant and recessive alleles.

Number of kernels/ row: Partial dominance effect of the parents was observed due to the interception of regression line above the point of origin of Wr axis. The scattered distribution of array points representing their respective parental number indicated the wide diversity among the parents.

All the parents except P₄ and P₅ formed one group where the parent P₃ had maximum concentration of dominant genes due to its proximity to the point of origin. The other parents occupied at the middle of the graph contained both dominant and recessive alleles.

Number of grains/cob: The graph showed that the regression line passed above the point of origin which indicated the presence of over dominance over all arrays. In the graph, the parent P₅ was nearest to the origin contained the maximum concentration of dominant genes and the parent P₃ being away from the origin carried maximum number of recessive genes. Other parents remained scattered along the regression line of the graph contained equal frequencies of dominant and recessive alleles.

Grain yield: The observed regression line intercepted the Wr axis above the point of origin showing partial dominance gene action in the expression of the character. The scattered distribution of array points indicated the diversity existed among the parents. It is clear from the graph that the array points representing their respective parental number are clustered into three major groups along the regression line. The parents P₂, P₃ and P₄ nearer to the origin formed one group whereas the parent P₅ had maximum concentration of dominant genes due to their proximity to the points of origin. The parents P₁ and P₆ which were away from the origin formed second group where P₂ being away from the origin carried maximum number of recessive genes.

The other parents formed the third group occupied at the middle of the graph contained equal frequencies of dominant and recessive alleles.

Table 4.2.1. Mean performances of 21 F₁ hybrids in 6×6 diallel crosses in maize

Crosses	DT	DS	DM	PH	EH	CL	CD	NRC	NKR	NGC	GYP
P1×P1	99.250	100.250	132.400	135.500	65.200	12.500	13.500	13.500	26.500	357.750	83.134
P1×P2	97.600	100.200	147.000	136.800	55.930	13.300	14.600	14.700	28.900	423.530	108.617
P1×P3	97.444	98.889	149.472	135.167	59.011	13.849	15.072	14.389	31.000	446.056	96.962
P1×P4	95.556	98.611	142.111	129.408	61.994	13.982	14.342	13.778	28.167	388.074	103.853
P1×P5	96.956	99.944	142.472	129.797	54.938	13.574	14.588	13.722	27.361	375.455	128.245
P1×P6	94.750	97.611	151.278	127.154	59.468	12.683	14.567	12.722	24.583	312.755	101.034
P2×P2	90.500	92.500	153.200	140.500	65.100	12.500	15.200	13.500	26.700	360.450	103.681
P2×P3	93.611	97.972	156.722	142.138	75.758	13.538	14.633	13.611	27.583	375.440	99.595
P2×P4	94.944	97.528	150.417	127.522	72.014	13.276	13.356	13.222	24.139	319.170	95.011
P2×P5	94.222	96.944	150.833	138.586	63.653	13.997	14.447	12.472	28.556	356.151	89.551
P2×P6	93.472	95.917	148.528	132.322	61.972	14.553	14.142	13.000	27.889	362.556	100.109
P3×P3	90.500	93.800	152.500	130.500	59.400	15.200	13.900	14.200	30.100	427.420	121.970
P3×P4	93.139	94.944	152.528	138.253	71.900	13.847	13.742	13.028	29.611	385.767	104.007
P3×P5	95.444	97.778	143.806	121.619	71.900	13.296	13.568	12.889	28.833	371.630	120.664
P3×P6	95.139	97.889	146.722	135.206	69.213	13.585	13.253	12.778	29.722	379.784	104.089
P4×P4	92.600	99.500	143.500	136.800	71.900	13.500	15.600	12.500	26.780	334.750	117.826
P4×P5	94.444	96.694	144.750	137.161	60.102	13.033	16.113	13.250	24.556	325.361	126.973
P4×P6	93.972	95.667	148.889	138.394	71.089	13.186	14.512	12.639	29.889	377.762	116.321
P5×P5	95.200	95.700	150.500	145.400	102.500	13.200	12.800	13.000	32.400	421.200	122.914
P5×P6	94.528	96.694	148.111	160.100	81.883	13.186	13.392	13.222	31.194	412.460	127.150
P6×P6	94.100	95.050	150.700	142.900	85.100	14.000	14.500	13.400	25.900	347.060	115.469
CV%	2.214	2.156	3.528	5.866	16.354	4.762	5.769	4.555	8.0548	9.7949	12.001
LSD 5%	3.052	2.971	3.723	9.833	18.778	3.148	2.425	1.153	1.364	95.841	27.132
SE of mean	0.233	0.226	0.284	0.751	1.434	0.241	0.185	0.088	0.529	7.321	2.073
Level of significance.	*	*	*	**	**	*	*	*	*	**	**

Table 4.2.2. Components of variation and their proportions for days to tasseling

Notation	Components of Variation	Proportional Values	
	Estimated Values	Proportion	Estimated Values
D	3.8697±1.824	$\sqrt{H1/D}$	1.548
F	6.519±4.457	H2/4H1	0.149
H1	9.274±4.6318	$[(4DH_1)^{1/2} + F] / [(4DH_1)^{1/2} - F]$	3.386
H2	5.5496±4.1377	h2/H2	-0.2349
h2	-1.3037±2.784	V1L1/WoLo1	4.236
E	2.9607±0.689	h ² NS	0.11008

Table 4.2.3. Components of variation and their proportions for days to silking

Notation	Components of Variation	Proportional Values	
	Estimated Values	Proportion	Estimated Values
D	3.121±2.290	$\sqrt{H1/D}$	2.068
F	6.445±5.595	H2/4H1	0.184
H1	13.356±5.814	$[(4DH_1)^{1/2} + F] / [(4DH_1)^{1/2} - F]$	2.993
H2	9.850±5.193	h2/H2	0.1077
h2	1.061±3.495	V1L1/WoLo1	9.824
E	2.850±0.865	h ² NS	0.0166

Table 4.2.4. Components of variation and their proportions for days to maturity

Notation	Components of Variation	Proportional Values	
	Estimated Values	Proportion	Estimated Values
D	1.0168±0.814	$\sqrt{H1/D}$	4.559
F	0.396±1.990	H2/4H1	0.166
H1	3.509±2.068	$[(4DH_1)^{1/2} + F] / [(4DH_1)^{1/2} - F]$	1.694
H2	2.3414±1.847	h2/H2	-0.235
h2	-0.551±1.243	V1L1/WoLo1	-73.065
E	0.993±0.308	h ² NS	0.160

Table 4.2.5. Components of variation and their proportions for plant height

Notation	Components of Variation		Proportional Values	
	Estimated Values		Proportion	Estimated Values
D	67.2918±10.879		(H1/D)1/2	0.848
F	68.4061±25.577		H2/4H1	0.1805
H1	48.4904±27.618		[(4DH ₁) ^{1/2} + F] / [(4DH ₁) ^{1/2} - F]	3.984
H2	35.0134±24.671		h2/H2	4.0846
h2	143.017±16.605		V1L1/WoLo1	1.1516
E	18.4208±4.112		h ² NS	0.1853

Table 4.2.6. Components of variation and their proportions for ear height

Notation	Components of Variation		Proportional Values	
	Estimated Values		Proportion	Estimated Values
D	7.3689±8.463		(H1/D)1/2	2.606
F	12.991±20.677		H2/4H1	0.2095
H1	50.049±21.486		[(4DH ₁) ^{1/2} + F] / [(4DH ₁) ^{1/2} - F]	2.0222
H2	41.945±19.194		h2/H2	0.3466
h2	14.539±12.918		V1L1/WoLo1	11.239
E	4.8068±3.199		h ² NS	0.0750

Table 4.2.7. Components of variation and their proportions for cob length

Notation	Components of Variation		Proportional Values	
	Estimated Values		Proportion	Estimated Values
D	0.6944±0.4515		√H1/D	1.6187
F	1.4062±1.1031		H2/4H1	0.1463
H1	1.8197±1.146		[(4DH ₁) ^{1/2} + F] / [(4DH ₁) ^{1/2} - F]	4.3398
H2	1.0651±1.023		h2/H2	0.1803
h2	0.1920±0.689		V1L1/WoLo1	5.8734
E	0.7643±0.1706		h ² NS	0.0203

Table 4.2.8. Components of variation and their proportions for cob diameter

Notation	Components of Variation	Proportional Values	
	Estimated Values	Proportion	Estimated Values
D	1.10970±0.399	$\sqrt{H1/D}$	1.522
F	2.1049±0.977	H2/4H1	0.1387
H1	2.5713±1.015	$[(4DH_1)^{1/2} + F] / [(4DH_1)^{1/2} - F]$	4.3060
H2	1.4268±0.9070	h2/H2	-0.3579
h2	-0.5107±0.610	V1L1/WoLo1	5.1063
E	0.9260±0.1511	h ² N	0.0549

Table 4.2.9. Components of variation and their proportions for number of rows/cob

Notation	Components of Variation	Proportional Values	
	Estimated Values	Proportion	Estimated Values
D	1.5357±0.607	$\sqrt{H1/D}$	1.6218
F	2.1809±1.485	H2/4H1	0.2068
H1	4.0396±1.543	$[(4DH_1)^{1/2} + F] / [(4DH_1)^{1/2} - F]$	2.5575
H2	3.3417±1.378	h2/H2	-0.241
h2	-0.807±0.927	V1L1/WoLo1	3.648
E	1.464±0.229	h ² NS	0.0113

Table 4.2.10. Components of variation and their proportions for number of kernels/row

Notation	Components of Variation	Proportional Values	
	Estimated Values	Proportion	Estimated Values
D	-0.5696±1.795	$\sqrt{H1/D}$	6.2486
F	1.8679±4.386	H2/4H1	0.2171
H1	22.2435±4.558	$[(4DH_1)^{1/2} + F] / [(4DH_1)^{1/2} - F]$	1.7113
H2	19.3221±4.072	h2/H2	6.8059
h2	131.5054±2.740	V1L1/WoLo1	27.125
E	2.988±0.402	h ² NS	0.265

Table 4.2.11. Components of variation and their proportions for number of grains/cob

Notation	Components of Variation	Proportional Values	
	Estimated Values	Proportion	Estimated Values
D	77.847±29.919	$\sqrt{H1/D}$	1.4743
F	37.384±73.0943	H2/4H1	0.2243
H1	169.2121±75.954	$[(4DH_1)^{1/2} + F] / [(4DH_1)^{1/2} - F]$	1.3890
H2	151.8614±67.8519	h2/H2	1.1937
h2	181.288±45.668	V1L1/WoLo1	1.8398
E	7.2261633±11.308	h ² NS	0.3901

Table 4.2.12. Components of variation and their proportions for grain yield/plant

Notation	Components of Variation	Proportional Values	
	Estimated Values	Proportion	Estimated Values
D	16.3356±10.529	$\sqrt{H1/D}$	1.9605
F	1.5754±25.724	H2/4H1	0.2319
H1	62.793±26.730	$[(4DH_1)^{1/2} + F] / [(4DH_1)^{1/2} - F]$	1.051
H2	58.269±23.879	h2/H2	1.024
h2	63.071±16.072	V1L1/WoLo1	2.533
E	9.4061±3.979	h ² NS	0.318

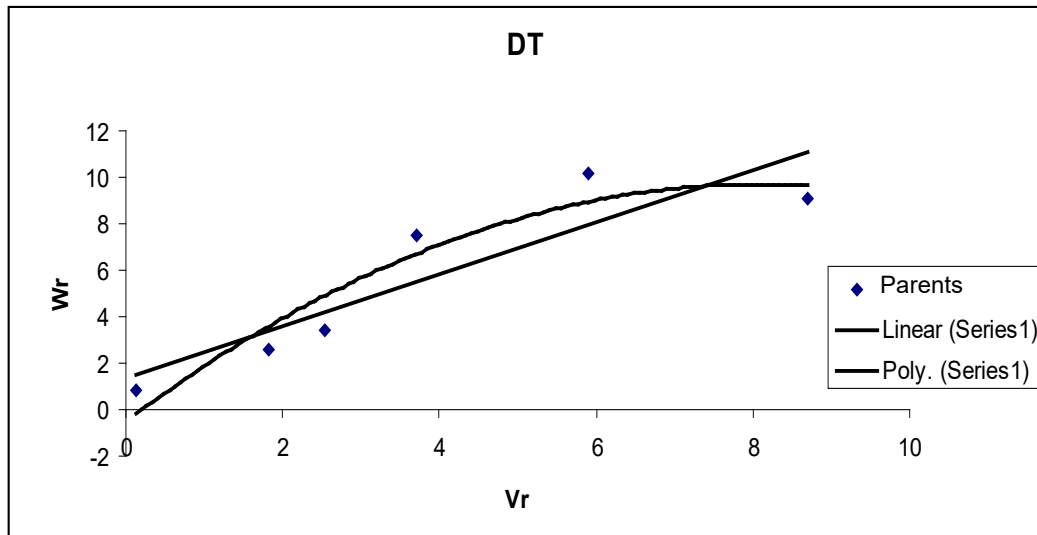

Graph 4. 2.1. Vr–Wr graph for days to tasseling in 6x6 diallel cross in maize

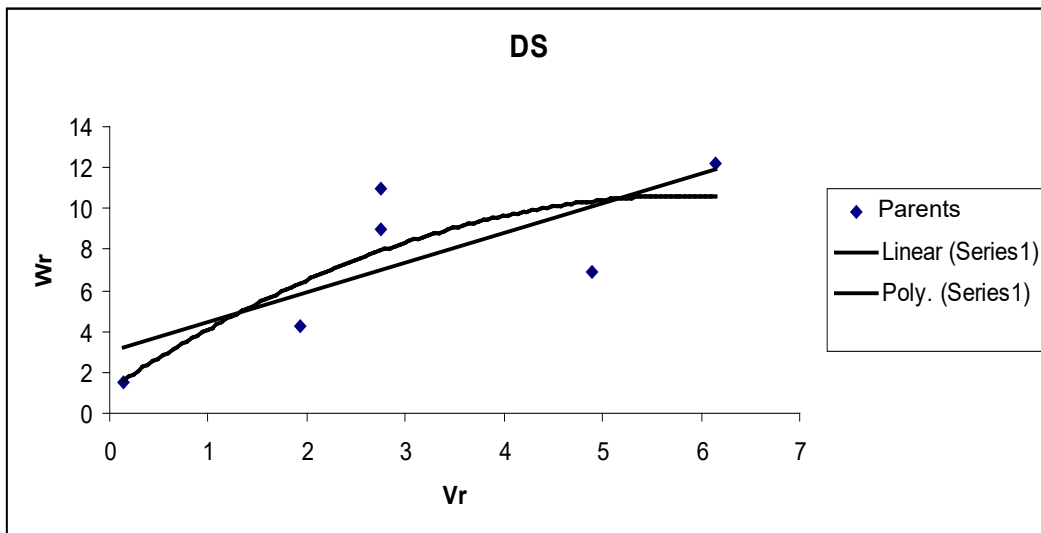

Graph 4. 2. 2. Vr–Wr graph for days to silking in 6x6 diallel cross in maize

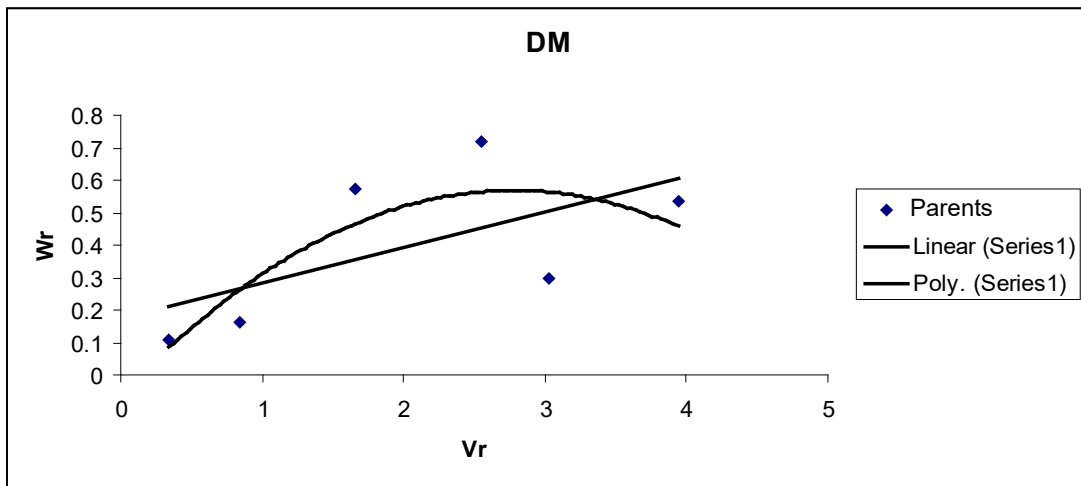

Graph 4. 2. 3. Vr–Wr graph for days to maturity in 6x6 diallel cross in maize

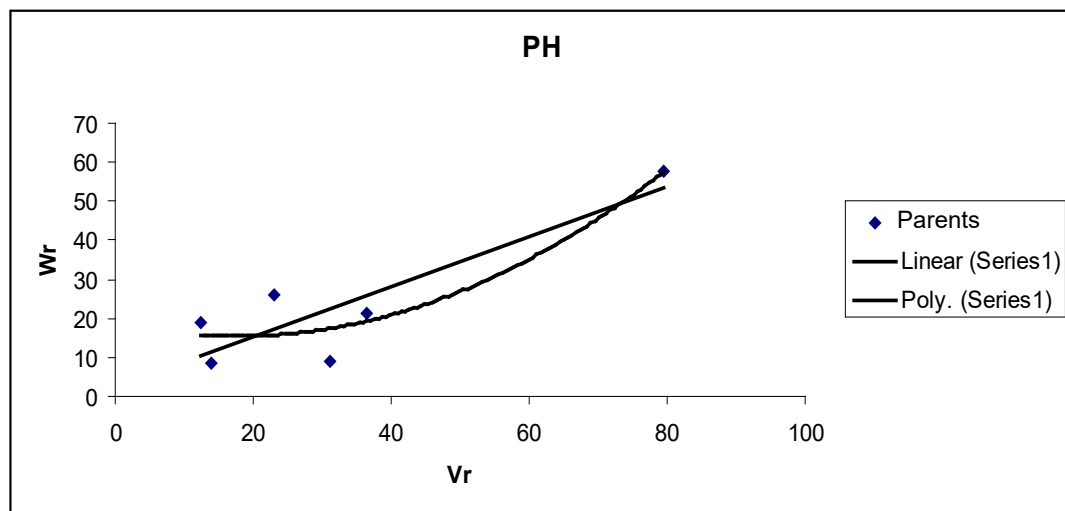

Graph 4. 2. 4. Vr–Wr graph for plant height in 6x6 diallel cross in maize

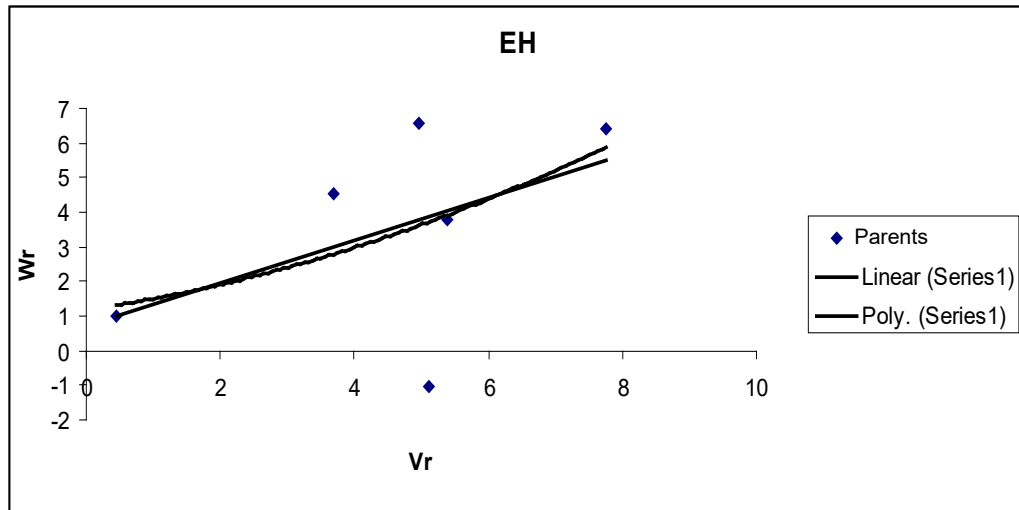

Graph 4. 2. 5. Vr–Wr graph for ear height in 6x6 diallel cross in maize

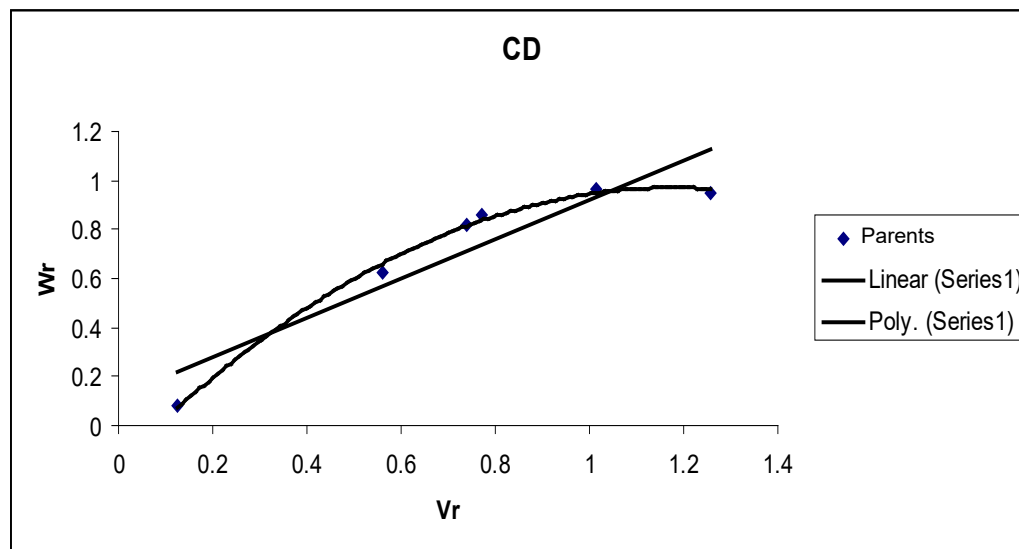

Graph 4. 2. 6. Vr–Wr graph for cob diameter in 6x6 diallel cross in maize

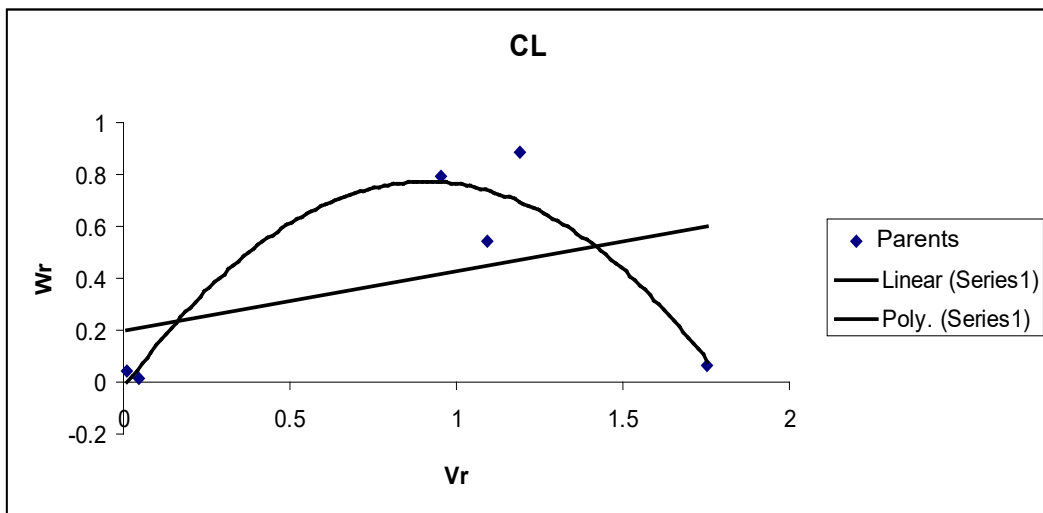

Graph 4. 2.7. Vr–Wr graph for cob length in 6x6 diallel cross in maize

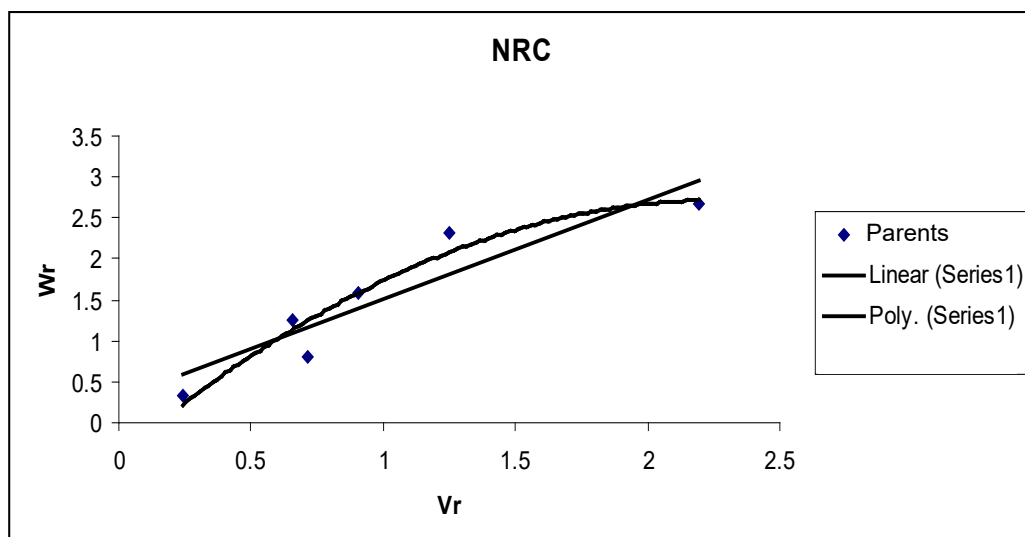

Graph 4. 2. 8. Vr–Wr graph for number of kernels/cob in 6x6 diallel cross in maize

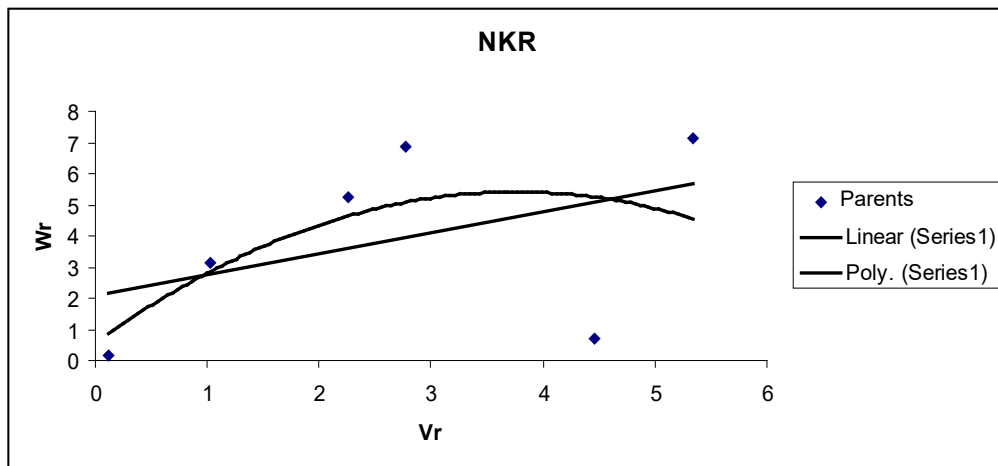

Graph 4. 2. 9. Vr–Wr graph for number of kernels/row in 6x6 diallel cross in maize

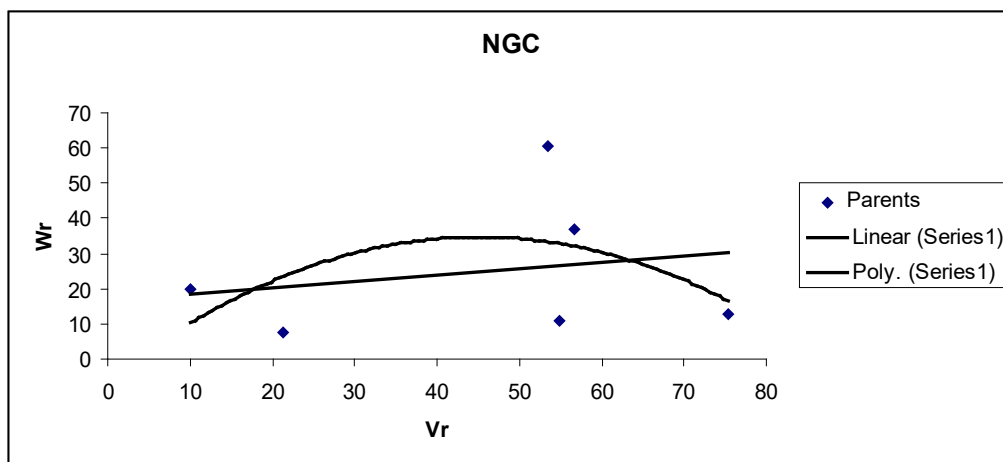

Graph 4. 2.10. Vr–Wr graph for number of grains/cob in 6x6 diallel cross in maize

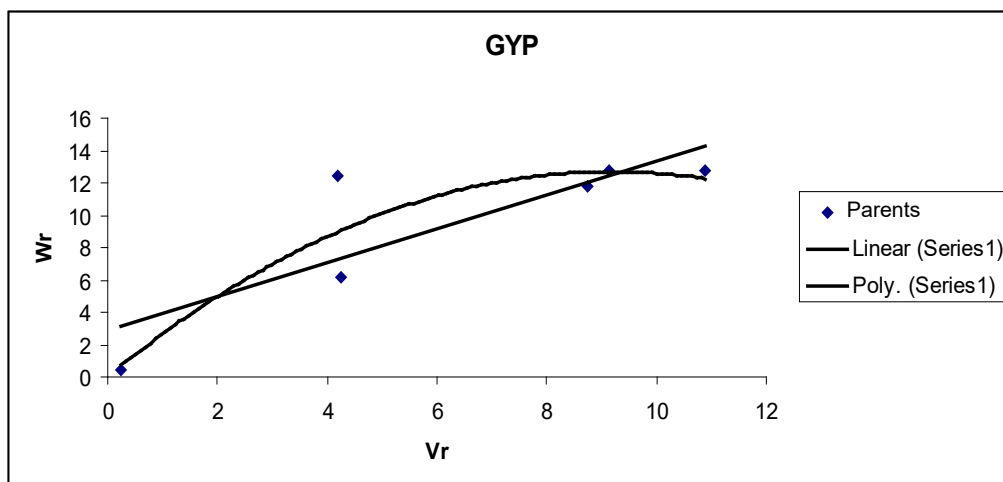

Graph 4. 2.11. Vr–Wr graph for grain yield/plant in 6x6 diallel cross in maize

4.2.2 COMBINING ABILITY FOR GRAIN YIELD AND YIELD COMPONENTS

Variance Analysis

The analysis of variance revealed highly significant difference for all the characters, indicating the existence of wider genetic variability among the lines. Both general combining ability (GCA) and specific combining ability (SCA) variances were found to be highly significant (Table 4.2.13) for all the characters studied which indicated that both additive and non-additive gene action played predominant role for expression of these characters. Relative importance of GCA and SCA was calculated, closer the ratio is to unity greater is the predictability based on GCA alone.

In the present study GCA/SCA variance was observed to be unity for cob length, cob diameter and number of rows/cob indicating equal importance of both additive and non additive gene effects.

The SCA component of variance was higher than GCA component of variance for the characters like plant height, cob diameter and number of rows/cob indicating the predominance of non-additive or dominant gene action.

High magnitude of SCA components were predominant indicating the dominance and epistatic interaction for these characters. Average GCA: SCA ratio for four characters was above unity.

General Combining Ability

The GCA effect (g_i) represents the additive nature of gene action. The nature (direction or sign) and magnitude of g_i both are considered. Besides, *per se* performance of the parent is also considered together with g_i since the former offers authenticity to g_i as a guide to select the parent. GCA and SCA variances with each parent play a significant role in the choice of the parent. A parent with higher positive significant GCA effect is considered as a good general combiner. A parent showing high GCA and SCA variances is a better parent for creating high yielding specific combination.

The magnitude and direction of the significant effect for six parents provides meaningful comparison and would give clue to the future breeding program.

General combining ability (GCA) effects for grain yield and yield components are presented in Table 4.2.14. In this study, days to maturity, cob height and number of kernels/cob of the inbred lines with significant and negative effects were considered as good general combiners, while grain yield and other yield components of inbred with significant and positive effects were considered as good general combiners.

Highly significant and positive GCA effect of the parents P₄, P₅ and P₆ were observed for grain yield (Table 4.2.14.). P₁ and P₂ parents showed significant and negative GCA effect. Inbred parent P₃ showed non-significant GCA effect for this character.

For days to tasseling the P₂, P₃, P₄ and P₆ parents showed non-significant negative GCA. Estimates of GCA were positively non-significant for P₁ and P₅. Inbred parents P₂, P₃, P₄ and P₆ showed non-significant negative GCA effect for days to silking but the parents P₁ and P₅ showed positive non-significant GCA (Table 4.2.14).

The GCA effect of P₁, P₂ and P₃ was significantly negative for days to maturity. Parents P₄, P₅ and P₆ were found to show non-significant negative GCA effect for the character (Table 4.2.14). For plant height the GCA effects of the parents, P₁, P₂ and P₃ showed non-significant positive whereas negative non-significant GCA effect was observed in P₄, P₅ and P₆ (Table 4.2.14). The inbred parents P₁, P₅ and P₆ showed positive significant GCA for cob height, other parents showed non-significant negative GCA effect for the character (Table 4.2.14).

The parent P₃ showed non-significant positive GCA for cob length. Non-significant negative GCA was found for other parents (Table 4.2.14). For cob diameter it was observed that the parents P₃, P₅ and P₆ showed non significant

negative GCA. The remaining three parents showed non-significant positive GCA for cob diameter (Table 4.2.14).

The inbreds P₁, P₂ and P₃ showed non-significant positive GCA for number of rows/cob and also P₄, P₅ and P₆ showed non-significant negative GCA for this trait (Table 4.7.2). For number of kernels/row it was found that parents P₃, P₅ and P₆ showed non-significant positive GCA. Other parents like P₁, P₂ and P₄ showed non-significant negative GCA for the trait (Table 4.2.14).

The parents P₁, P₂, P₃, and P₅ showed significant positive GCA for number of grains/cob. Significant negative GCA was found for P₄ and P₆ (Table 4.2.14).

Inbred parents P₁, P₂, P₄, P₅ and P₆ showed significant positive GCA effect for grain yield but the parents P₃ showed positive non-significant GCA (Table 4.2.14).

From the study, it is concluded that the parents P₁, P₂, P₄ and P₅ are good general combiner and might be used for hybrid variety development program.

Specific Combining Ability

The SCA effects signify the role of non-additive gene action in the expression of the characters. It denotes the highly specific combining ability leading to the highest performance of some specific cross combinations. For this reason it relates to a particular cross. The estimates of SCA effects are presented in Tables 4.2.14 - 4.2.25.

SCA effects for grain yield was observed among 15 crosses, eight crosses like P₁×P₂, P₁×P₅, P₂×P₅, P₃×P₅, P₄×P₅, P₂×P₆, P₄×P₆ and P₅×P₆ showed highly significant and positive SCA. Five other crosses, P₁×P₃, P₂×P₄, P₃×P₄, P₁×P₆ and P₃×P₆ showed significant negative SCA effect for the character.

For days to tasseling seven crosses P₁×P₂, P₂×P₄, P₁×P₅, P₂×P₅, P₃×P₅, P₁×P₆ and P₃×P₆ showed significant negative SCA which is desirable. Regarding days to silking three crosses, P₃×P₄, P₁×P₅ and P₃×P₆ showed desired significant negative SCA, P₂×P₅, P₃×P₅, P₁×P₆ and P₃×P₆ showed significant negative SCA, five crosses P₃×P₄, P₁×P₅, P₄×P₅, P₃×P₆ and P₅×P₆.

For days to maturity, five crosses $P_1 \times P_2$, $P_1 \times P_3$, $P_2 \times P_3$, $P_3 \times P_4$ and $P_1 \times P_6$ were positive significant and the rest three crosses $P_3 \times P_5$, $P_2 \times P_6$ and $P_3 \times P_6$ showed significant negative SCA effect for the character (Table 4.2.17.).

Regarding plant height seven crosses, $P_1 \times P_4$, $P_1 \times P_5$, $P_1 \times P_6$, $P_2 \times P_4$, $P_2 \times P_5$, $P_2 \times P_6$ and $P_3 \times P_5$ and $P_3 \times P_6$ showed desired significant negative SCA, six crosses $P_1 \times P_2$, $P_1 \times P_3$, $P_2 \times P_3$, $P_3 \times P_4$, $P_4 \times P_6$ and $P_5 \times P_6$ showed positive significant for this trait.(Table 4.2.18). Regarding ear height $P_1 \times P_2$, $P_1 \times P_5$, $P_2 \times P_5$, $P_3 \times P_5$, $P_4 \times P_5$, $P_1 \times P_6$ and $P_2 \times P_4$ showed significant negative SCA. The rest six crosses $P_1 \times P_3$, $P_2 \times P_3$, $P_1 \times P_4$, $P_2 \times P_4$, $P_4 \times P_6$ and $P_5 \times P_6$ exhibited significant positive SCA for the trait (Table 4.2.19). Regarding cob length three crosses like $P_2 \times P_4$, $P_1 \times P_5$ and $P_2 \times P_6$ showed significant positive SCA, four crosses had significant negative SCA (Table 4.2.20). For cob diameter two crosses $P_1 \times P_3$ and $P_3 \times P_5$ exhibited positive significant SCA and the two crosses $P_3 \times P_4$ and $P_1 \times P_5$ exhibited significant negative SCA. Other crosses showed non-significant SCA for the trait (Table 4.2.21). For number of rows/cob three crosses $P_1 \times P_2$, $P_1 \times P_4$ and $P_1 \times P_5$ showed significant positive SCA. On the other hand, negative significant SCA was observed for four crosses $P_2 \times P_3$, $P_3 \times P_5$, $P_1 \times P_6$ and $P_1 \times P_6$ for the trait (Table 4.2.22).

For number of kernels/ row five crosses $P_1 \times P_2$, $P_1 \times P_5$, $P_4 \times P_5$, $P_4 \times P_6$ and $P_5 \times P_6$ showed significant positive SCA whereas three crosses $P_2 \times P_4$, $P_2 \times P_5$ and $P_3 \times P_6$ showed significant negative SCA and the other seven crosses exhibited non significant SCA for the trait (Table 4.2.23). Regarding number of grains/cob, six crosses $P_1 \times P_2$, $P_1 \times P_4$, $P_1 \times P_5$, $P_4 \times P_5$ and $P_5 \times P_6$ showed positive significant SCA whereas nine crosses showed significant negative SCA (Table 4.2.24). For grain yield/plant, twelve crosses showed significant SCA whereas six crosses $P_1 \times P_2$, $P_1 \times P_5$, $P_2 \times P_5$, $P_4 \times P_5$, $P_2 \times P_6$, $P_4 \times P_6$ and $P_5 \times P_6$ were positive and the rest six were negative for the character (Table 4.2.25).

The proportion of GCA/SCA was more than unity for all the studied characters, suggesting that additive gene effects were more important than the non-additive ones in the expression of these characters.

Table 4.2.13. Analysis of variance for combining ability analysis for grain yield and its components in 6×6 diallel cross in maize

Characters	Source of variation	df	Sum of squares	Mean squares	F.value	GCA/SGA
DT	GCA	5	75.048	15.009	1.532	3.159
	SCA	15	71.9284	4.795		
	Crosses	20	146.976	7.348		
	Error	40	136.938	4.795		
DS	GCA	5	52.365	10.473	1.831	2.365
	SCA	15	66.406	4.427		
	Crosses	20	118.771	5.938		
	Error	40	129.709	3.242		
DM	GCA	5	927.511	185.502	15.279	4.414
	SCA	15	630.427	42.028		
	Crosses	20	1557.938	77.896		
	Error	40	203.957	5.09892		
PH	GCA	5	730.553	146.11069	5.295	0.7025
	SCA	15	3034.03	202.2687		
	Crosses	20	3764.584	188.229		
	Error	40	1421.831	35.545		
EH	GCA	5	3533.856	706.771	2.812	2.8225
	SCA	15	3756.084	250.405		
	Crosses	20	7289.941	364.497		
	Error	40	5185.474	129.636		
CL	GCA	5	58.668	11.733	2.178	1.7577
	SCA	15	100.127	6.675		
	Crosses	20	158.796	7.939		
	Error	40	145.775	3.644		
CD	GCA	5	20.124	4.024	2.174	0.8165
	SCA	15	73.927	4.928		
	Crosses	20	94.052	4.702		
	Error	40	86.51	2.162		
NRC	GCA	5	2.167	0.433	1.112	0.745
	SCA	15	8.718	0.581		
	Crosses	20	10.886	0.544		
	Error	40	19.564	0.489		
NKR	GCA	5	470.348	94.069	1.843	7.764
	SCA	15	181.74	12.116		
	Crosses	20	652.088	32.604		
	Error	40	707.584	17.689		
NGC	GCA	5	64582.993	12916.598	1.749	3.6169
	SCA	15	53567.158	3571.143		
	Crosses	20	118150.15	5907.507		
	Error	40	135068.29	3376.707		
GYP	GCA	5	5175.866	1035.173	1.749	3.6167
	SCA	15	4293.246	286.216		
	Crosses	20	9469.112	473.455		
	Error	40	10825.162	270.629		

Table 4.2.14. Estimation of GCA effects of the parents for different characters in maize

Parents	DT	DS	DM	PH	CH	CL	CD	NRC	NKR	NGC	GYP
P ₁	1.422	1.265	-4.448**	0.388	-8.390**	-0.045	0.051	0.388	-0.237	18.422**	-8.301**
P ₂	-0.743	-0.134	2.659**	0.132	-0.208	-0.018	0.336	0.132	-0.846	7.419**	-7.018**
P ₃	-0.428	-0.267	2.975**	0.173	-1.030	0.248	-0.271	0.173	1.045	19.055**	0.358
P ₄	-0.547	-0.487	-1.402	-0.198	-0.891	-0.199	0.320	-0.198	-1.062	-15.88**	3.178**
P ₅	0.452	0.114	-0.576	-0.252	7.130**	-0.059	-0.373	-0.252	0.789	2.703**	8.877**
P ₆	-0.155	-0.491	0.793	-0.242	3.390**	0.074	-0.063	-0.242	0.311	-2.880**	2.906**

Table 4.2.15. Specific combining ability (SCA) effect for days to tasseling in 6×6 diallel cross in maize

Parent	P ₂	P ₃	P ₄	P ₅	P ₆
P ₁	2.476**	1.6009	-0.203	0.221	-1.201
P ₂		0.0967	1.549	0.0538	-0.3127
P ₃			-0.569	0.9588	1.0355
P ₄				0.0780	-0.0086
P ₅					-0.230

Table 4.2.16. Specific combining ability effect for days to silking in 6×6 diallel cross in maize

Parent	P ₂	P ₃	P ₄	P ₅	P ₆
P ₁	4.757**	0.6708	0.614	-2.343**	-0.384
P ₂		2.153**	0.927	-0.254	-0.678
P ₃			-3.519**	0.708	-3.427**
P ₄				-3.154**	-0.154
P ₅					-2.146**

Table 4.2.17. Specific combining ability effect for days to maturity in 6×6 diallel cross in maize

Parent	P ₂	P ₃	P ₄	P ₅	P ₆
P ₁	2.244**	3.178**	0.192	-0.270	7.163**
P ₂		3.319**	1.391	0.981	-2.694**
P ₃			3.185**	-6.364**	-4.813**
P ₄				-1.039	1.730
P ₅					0.191

Table 4.2.18. Specific combining ability effect for plant height in 6×6 diallel cross in maize

Parent	P ₂	P ₃	P ₄	P ₅	P ₆
P ₁	2.130**	4.121**	-2.574**	-7.139**	-7.866**
P ₂		7.677**	-7.871**	-3.763**	-6.110**
P ₃			5.929**	-15.662**	-0.155
P ₄				-1.058	2.095**
P ₅					18.843**

Table 4.2.19. Specific combining ability effect for ear height in 6×6 diallel crosses in maize

Parent	P ₂	P ₃	P ₄	P ₅	P ₆
P ₁	-7.487**	6.7617**	7.332**	-9.197*8	-5.590**
P ₂		5.367**	6.191**	-3.174*8	-17.434**
P ₃			1.986	-10.609**	1.394
P ₄				-10.489**	2.534**
P ₅					10.205**

Table 4.2.20. Specific combining ability effect for cob length in 6×6 diallel crosses in maize

Parent	P ₂	P ₃	P ₄	P ₅	P ₆
P ₁	-0.065	0.171	0.752	2.202**	-0.822
P ₂		-3.168**	4.022**	0.602	3.021**
P ₃			0.325	-3.367**	-2.215**
P ₄				-4.183**	-0.1613
P ₅					-0.304

Table 4.2.21. Specific combining ability effect for cob diameter in 6×6 diallel crosses in maize

Parent	P ₂	P ₃	P ₄	P ₅	P ₆
P ₁	-0.102	2.202**	-0.248	-3.147**	0.741
P ₂		1.173	0.296	0.630	-0.103
P ₃			-2.949**	4.361**	0.623
P ₄				0.250	0.373
P ₅					-0.516

Table 4.2.22. Specific combining ability effect for number of rows/cob in 6×6 diallel cross in maize

Parent	P ₂	P ₃	P ₄	P ₅	P ₆
P ₁	7.603**	0.253	2.248**	3.398**	-4.790**
P ₂		-2.179**	-0.457	-0.617	0.093
P ₃			-0.480	-5.041**	-5.247**
P ₄				0.231	0.208
P ₅					0.451

Table 4.2.23. Specific combining ability effect for number of kernels/row in 6×6 diallel cross in maize

Parent	P ₂	P ₃	P ₄	P ₅	P ₆
P ₁	3.034**	-1.253	-0.324	4.1236**	1.300
P ₂		-0.058	-3.579**	-4.298**	-1.121
P ₃			-1.101	-1.635	-2.392**
P ₄				3.126**	4.253**
P ₅					2.801**

Table 4.2.24. Specific combining ability effect for number of grains/cob in 6×6 diallel cross in maize

Parent	P ₂	P ₃	P ₄	P ₅	P ₆
P ₁	56.096**	-11.127**	3.251**	16.295**	-5.745**
P ₂		-6.360**	-32.514**	-71.930**	-13.545**
P ₃			-26.795**	-23.411**	-25.542**
P ₄				24.238**	7.699**
P ₅					25.821**

Table 4.2.25. Specific combining ability effect for grain yield/plant in 6×6 diallel cross in maize

Parent	P ₂	P ₃	P ₄	P ₅	P ₆
P ₁	15.880**	-3.150**	0.920	4.613**	-1.626
P ₂		-1.800	-9.205**	20.363**	3.834**
P ₃			-7.585**	-6.627**	-7.231**
P ₄				6.861**	2.181**
P ₅					7.309**

4.2.3 HETEROSIS STUDY

Estimation of Mid-parent and Better-parent

The estimation of percent heterosis observed in F_1 generation over mid-parent and better-parent for different characters are presented in Tables 4.2.26- 4.2.31. Heterosis over mid-parent for different crosses was recorded non-significant in some crosses viz., $P_2 \times P_6$, $P_3 \times P_4$, $P_4 \times P_5$ and $P_4 \times P_6$ for days to tasseling. The highest percent of heterosis over mid-parent was recorded to be 4.165 in $P_1 \times P_2$ for this character (Table 4.2.26). Out of the cross combinations, eleven crosses showed significant heterosis over better-parent for days to tasseling. Most of the crosses showed highly significant positive heterosis both over mid-parent and better-parent for days to silking (Table 4.2.26.).

Most of the crosses showed significant positive heterosis over mid-parent and better-parent for days to maturity. The highest heterosis with 10.185 was recorded in $P_1 \times P_6$ over mid-parent and that of 10.663 was recorded in $P_3 \times P_5$ over better-parent.

For plant height nine crosses showed negative but significant heterosis and rest of them showed positive significant heterosis over mid-parent. All the crosses except only one cross $P_3 \times P_6$ showed positive significant heterosis over better-parent for this character.

Heterosis over mid-parent for different crosses was recorded significant but negative heterosis in some crosses viz., $P_1 \times P_2$, $P_1 \times P_5$, $P_1 \times P_6$, $P_2 \times P_5$, $P_2 \times P_6$, $P_3 \times P_5$, $P_4 \times P_5$, $P_4 \times P_6$ and $P_5 \times P_6$ for ear height. The highest percent of heterosis over mid-parent was recorded to be 9.060 in $P_2 \times P_3$ for this character (Table 4.2.28). All the cross combinations except $P_2 \times P_4$ showed significant heterosis over better-parent and the highest percent positive heterosis 45.863 was recorded in $P_1 \times P_5$. Regarding mid-parent and better-parent heterosis, most of the crosses for cob length exhibited non-significant results. From Table 4.2.28, it is observed

that three crosses showed significant positive heterosis over mid parent and better parent but rest of the crosses showed significant negative heterosis.

Two crosses showed non-significant negative heterosis in cob diameter. Out of fifteen cross combinations, five F_1 showed positive significant heterosis over mid-parent for number of rows/cob. Rest of them was found to be non-significant. Four non-significant values of -2.506, -3.531, -2.473 and -1.874 were estimated in $P_1 \times P_5$, $P_1 \times P_6$, $P_2 \times P_4$ and $P_3 \times P_5$ over mid-parent heterosis for number of kernels/row.

The highest significant positive heterosis percent over mid-parent of 3.043 was recorded in $P_4 \times P_6$. Different crosses for this character exhibited non-significant to significant, negative to positive heterosis over better-parent. The highest percent better-parent heterosis of 7.210 was recorded in $P_4 \times P_5$. All the F_1 s showed significant negative heterosis over mid-parent though six positive significant estimations were found in $P_1 \times P_2$, $P_1 \times P_3$, $P_1 \times P_4$, $P_3 \times P_4$, $P_4 \times P_6$ and $P_5 \times P_6$, respectively for number of grains/cob (Table 4.2.30). The highest significant positive heterosis percent over mid-parent of 59.096 was recorded in $P_1 \times P_2$ while all non-significant heterosis over better-parent were estimated for the above character. From Table 4.2.31, it is evident that most of the crosses over mid parent and better parent showed significant negative but rest of them showed both significantly positive and negative heterotic effect.

A wide range of variation from 1.732 to 15.209% over mid parent and -40.363 to 4.936% over better parent was observed. The cross $P_1 \times P_2$ showed the highest and significantly positive heterosis over mid parent (15.209%) and better parent (4.936%).

Table 4.2.26. Heterotic effect in F₁ generation over mid parent and better parent for days to tasseling and days to silking

Crosses	Days to tasseling			Days to silking		
	Mean	MP	BP	Mean	MP	BP
P ₁ ×P ₂	97.840	4.165**	1.756*	100.110	3.485**	2.360**
P ₁ ×P ₃	97.280	3.105**	1.196*	98.890	2.282**	1.140*
P ₁ ×P ₄	95.356	0.732*	0.726*	98.613	1.438*	0.863*
P ₁ ×P ₅	96.556	0.765*	0.473	99.943	2.718**	2.193**
P ₁ ×P ₆	94.750	-0.658*	1.333*	97.610	0.526*	0.140
P ₂ ×P ₃	93.610	1.843*	1.343*	97.973	2.490**	2.473**
P ₂ ×P ₄	94.943	2.726**	1.776*	97.526	1.476*	0.926*
P ₂ ×P ₅	94.223	0.840*	1.276*	96.946	0.846*	0.246
P ₂ ×P ₆	93.473	0.473	1.260*	95.916	-0.041	0.500*
P ₃ ×P ₄	93.140	0.423	0.026	94.946	-1.086	1.653*
P ₃ ×P ₅	95.443	1.560*	0.056	97.77	1.693*	1.076*
P ₃ ×P ₆	95.136	1.636*	0.403	97.890	1.948*	1.473*
P ₄ ×P ₅	94.443	0.110	1.056*	96.693	0.043	0.006
P ₄ ×P ₆	93.973	0.023	0.760*	95.666	-0.841*	0.933*
P ₅ ×P ₆	94.526	-0.590*	0.973*	96.696	0.138	0.003

Table 4.2.27. Heterotic effect in F₁ generation over mid parent and better parent for days to maturity and plant height (cm)

Crosses	Days to maturity			Plant height		
	Mean	MP	BP	Mean	MP	BP
P ₁ ×P ₂	146.223	3.681**	5.243**	136.246	-2.186**	4.253**
P ₁ ×P ₃	149.473	5.431**	4.993**	135.166	1.766*	1.200*
P ₁ ×P ₄	142.110	4.185**	0.123	129.406	-6.276**	6.960**
P ₁ ×P ₅	144.473	0.731	7.393**	129.800	-11.667**	16.775**
P ₁ ×P ₆	151.276	10.185**	2.710**	127.153	-8.996**	9.213**
P ₂ ×P ₃	156.723	3.756**	2.256**	142.134	6.670**	1.635**
P ₂ ×P ₄	152.416	3.566**	1.050*	127.523	-10.226**	12.973**
P ₂ ×P ₅	150.833	0.166	0.633	138.590	-4.943**	7.976**
P ₂ ×P ₆	148.526	3.490**	2.940**	132.323	-5.893**	8.176**
P ₃ ×P ₄	153.526	4.176**	1.940*	138.253	5.536**	3.253**
P ₃ ×P ₅	143.803	-8.363**	10.663**	121.620	-16.880**	24.946**
P ₃ ×P ₆	146.723	-4.793**	7.743**	135.206	2.023**	0.726
P ₄ ×P ₅	144.750	-1.301	5.116**	137.160	-3.623**	9.406
P ₄ ×P ₆	149.890	3.490**	0.323	138.393	2.926**	2.460**
P ₅ ×P ₆	148.176	-1.040**	1.690**	160.100	18.850**	13.532**

Table 4.2.28. Heterotic effect in F₁ generation over mid and better parent for ear height (cm) and cob length (cm)

Crosses	Ear height			Cob length		
	Mean	MP	BP	Mean	MP	BP
P ₁ ×P ₂	56.160	-9.873**	16.740**	13.587	-0.497	-1.247*
P ₁ ×P ₃	59.013	-0.820	1.486**	14.536	0.687	-0.297
P ₁ ×P ₄	61.993	-0.790	4.406**	16.700	3.600**	1.867*
P ₁ ×P ₅	54.936	-25.046**	45.863**	16.263	2.555*	1.430*
P ₁ ×P ₆	59.466	-10.250**	20.800**	11.883	-2.100*	-2.950*
P ₂ ×P ₃	75.760	9.060**	2.860**	11.667	-1.433*	-1.667*
P ₂ ×P ₄	72.016	2.366**	0.883	10.950	-1.400*	-2.383*
P ₂ ×P ₅	63.653	-23.196**	37.146**	13.250	0.233	-0.083
P ₂ ×P ₆	61.970	-14.613**	18.296**	13.000	2.343*	-0.333
P ₃ ×P ₄	71.900	8.450**	5.50**	14.460	-1.375*	1.593*
P ₃ ×P ₅	71.90	-8.750**	28.90**	13.00	-1.625*	-1.767*
P ₃ ×P ₆	69.213	-1.170	11.053**	12.200	-0.800*	-0.933*
P ₄ ×P ₅	60.103	-23.496**	40.696**	11.600	-1.375*	-1.983*
P ₄ ×P ₆	71.086	-2.246*	9.180**	12.700	0.450	-0.433
P ₅ ×P ₆	81.883	-8.650**	18.916**	13.830	-0.075	-0.350

Table 4.2.29. Heterotic effect in F₁ generation over mid and better parent for cob diameter (cm) and number of rows/cob

Crosses	Cob diameter			Number of rows/cob		
	Mean	MP	BP	Mean	MP	BP
P ₁ ×P ₂	13.956	0.734*	0.617*	14.666	1.400*	1.333*
P ₁ ×P ₃	15.073	3.167*	2.234*	14.386	0.970*	0.753*
P ₁ ×P ₄	14.343	-0.457	-1.707*	13.776	0.910*	0.576*
P ₁ ×P ₅	15.586	-0.641*	-0.950*	13.723	0.873*	0.523*
P ₁ ×P ₆	14.566	1.383*	1.283*	12.712	-0.443	0.476
P ₂ ×P ₃	12.633	2.250*	1.200*	13.610	0.126	0.023
P ₂ ×P ₄	13.354	0.250	-0.933*	13.220	0.286	0.113
P ₂ ×P ₅	14.450	1.248*	0.823*	12.470	-0.446	0.863*
P ₂ ×P ₆	15.143	0.650*	0.633*	13.001	-0.235	0.331
P ₃ ×P ₄	13.743	-2.916*	-5.100*	13.026	-0.056	0.606*
P ₃ ×P ₅	12.570	2.108*	1.483*	12.886	-0.180	0.746*
P ₃ ×P ₆	13.253	1.507*	0.473	12.776	-0.606*	0.856*
P ₄ ×P ₅	15.056	-0.175	-1.733*	13.250	0.733*	0.716*
P ₄ ×P ₆	14.513	0.083	-1.066*	12.640	-0.193	0.493
P ₅ ×P ₆	12.393	-0.0917	-0.500*	13.223	0.406	0.0901

Table 4.2.30. Heterotic effect in F₁ generation over mid and better parent for number of kernels/row and number of grains/cob

Crosses	Number of kernels/row			Number of grains/cob		
	Mean	MP	BP	Mean	MP	BP
P ₁ ×P ₂	28.780	1.296*	0.813*	383.670	53.725**	17.436**
P ₁ ×P ₃	31.000	2.183**	1.333*	342.503	-19.745**	-88.336**
P ₁ ×P ₄	28.166	1.070	0.200	366.843	11.913**	-49.360**
P ₁ ×P ₅	27.360	-2.506**	4.406**	400.020	23.741**	58.880**
P ₁ ×P ₆	24.583	-3.531**	-3.683**	356.886	6.118**	-50.993**
P ₂ ×P ₃	27.583	-0.750*	2.083**	351.803	-46.733**	-79.037**
P ₂ ×P ₄	24.140	-2.473**	2.860**	335.610	-55.608**	-80.593**
P ₂ ×P ₅	28.556	-0.826*	3.210**	316.326	-96.240**	-142.573**
P ₂ ×P ₆	27.890	0.256	0.376	353.620	-33.437**	-54.260**
P ₃ ×P ₄	29.610	1.663*	0.056	367.387	-56.135**	-63.453**
P ₃ ×P ₅	28.831	-1.874*	-2.912**	390.903	-53.967**	-67.997**
P ₃ ×P ₆	29.723	0.756*	0.059	367.680	-51.680**	-63.160**
P ₄ ×P ₅	24.556	-4.440**	7.21**	448.883	10.962**	-10.387**
P ₄ ×P ₆	30.290	3.043**	2.023**	410.883	-1.158	-5.320*
P ₅ ×P ₆	31.193	1.176*	0.573	449.137	15.747**	-9.763**

Table 4.2.31. Heterotic effect in F₁ generation over mid and better parent for grain yield/plant (g)

Crosses	Grain yield/plant		
	Mean	MP	BP
P ₁ ×P ₂	108.617	15.209**	4.936**
P ₁ ×P ₃	96.962	-5.590**	-25.008**
P ₁ ×P ₄	103.853	3.372**	-13.973**
P ₁ ×P ₅	113.245	6.721**	-16.669**
P ₁ ×P ₆	101.034	1.732*	-14.435**
P ₂ ×P ₃	99.595	-13.23**	-22.375**
P ₂ ×P ₄	95.011	-15.742**	-15.742**
P ₂ ×P ₅	89.551	-27.246**	-40.363**
P ₂ ×P ₆	100.109	-9.466**	-15.360**
P ₃ ×P ₄	-15.360	-15.891**	-17.963**
P ₃ ×P ₅	110.664	-15.278**	-19.250**
P ₃ ×P ₆	104.089	-14.630**	-17.881**
P ₄ ×P ₅	126.973	3.103**	-2.941**
P ₄ ×P ₆	116.321	-0.327	-1.505*
P ₅ ×P ₆	127.150	4.457**	-2.764**

DISCUSSION

GENETIC VARIABILITY

The magnitude of variability present in a crop species is of utmost importance as it provides the basis for effective selection. In the present study, genetic variability among twenty five inbred lines of maize was assessed for grain yield and important yield components. The results (Table 4.1.10) revealed that GCV was less than its corresponding estimates of PCV for all the traits which indicated significant role of environment in the expression of these traits. The high values of genotypic coefficient of variation for cob height, days to silking, number of kernels/cob and grain yield indicated high degree of genetic variability for these characters. Similar results have also been obtained by Alam (2009). On the contrary, Satyanarayana and Saikumar (1995) recorded low genotypic coefficient of variation for grain yield. In crop improvement, only the genetic component of variation is important since only it is transmitted to the next generation. Although high heritability estimates have been found to be helpful in making selection of superior lines.

On the basis of phenotypic performance, Wannows *et al.* (2010) suggested that heritability estimates along with genetic gain were more useful in predicting the effect for selecting the best individual. Among the quantitative characters studied, the degree of heritability was found to be different.

Heritability estimate in broad sense was highest for days to silking followed by days to maturity, cob length and days to tasseling. Results showed that high heritability estimates were detected for days to silking, cob height, number of kernels/row, days to tasseling and yield, emphasizing that the additive genetic variation was the major component of genetic variation in the inheritance of these traits and the effectiveness of selection in the early segregating generations of the studied hybrids for improving these traits. Higher genetic advance for number of grains/cob, days to silking, days to tasseling, plant height and grain yield depicts additive gene effects.

High heritability estimates for plant height, cob height, number of rows/cob and number of kernels/row were also reported by Yasien (2000) and Abd El-Sattar (2003). Similar results have been reported in maize by Wannows *et al.* (2010) and Alam (2009).

High genotypic coefficient of variation and high to moderate heritability coupled with high genetic advance as percentage of mean for cob height, number of grains/cob, days to silking, cob diameter and grain yield indicating that these characters might be transmitted to the progenies. Therefore, selection of parents based on the superior phenotypes for these characters may be effective in hybridization program to develop high performing maize hybrids.

CORRELATION COEFFICIENT

The correlation coefficient between grain yield/plant and its component characters and between the various components themselves were estimated at the genotypic and phenotypic levels. The study reveals that in most of the cases, the values of r_g were higher than the corresponding r_p indicating less pronounced environmental effect. Lower r_p than r_g indicates that both environmental and genotypic correlations in those cases act in the same direction and finally maximize their expression at phenotypic level.

In this study, the traits studied were positively correlated with grain yield (Tables 4.1.12 and 4.1.13). The highest significant positive correlation with grain yield was shown by number of grains/cob followed by number of kernels/row and days to maturity. Similar results have been reported in maize by Swarnalatha and Mohammad (2001), Mohan *et al.* (2002), Abd EL-Aty and Katta (2002), Mohammadia *et al.* (2003), Ahmed (2004), Sadek *et al.* (2006) and Aydin *et al.* (2007).

Cob length showed significant and positive genotypic correlation with cob height; on the other hand, it was significantly and negatively correlated with days to maturity. This result agreed with those mentioned by Soliman *et al.* (1999), Yasien (2000), Mohammadia *et al.* (2003) and Sadek *et al.* (2006).

Cob diameter had significant and positive correlations with days to maturity while it showed significant and negative correlations with cob height. Number of rows/cob showed significant and negative correlations with cob height. Such results are in harmony with those obtained by Salami *et al.* (2007), Yasien (2000), Amin *et al.* (2003) and Mohammadia *et al.* (2003).

As yield (grain weight/plant) is the ultimate goal, the positive association of these characters will help for selecting best genotype. Similar results have also been reported by Mohan *et al.* (2002), Alam (2009) and Rafiq *et al.* (2010). In general, the existence of positive associations in the present study among the grain yield and cob length, number of kernels/row and number of grains/cob suggests that an increment of production may be achieved upon improving either one or more of these traits.

PATH COEFFICIENT

The analysis of path coefficient has (Tables 4.1.14 and 4.1.15) been made to identify the important yield contributors by estimating the direct effects of the contributing characters to yield and separating the direct from the indirect effects through other related characters by partitioning the correlation coefficient and finding out the relative importance of different characters as selection criteria. The estimates of direct and indirect effects of the eight yield related characters *viz.* days to maturity, plant height, ear height, cob length, cob diameter, number of rows/cob, number of kernels/row, number of grains/cob on grain yield are presented in Table 4.1.14.

The highest direct effect on grain yield was exhibited by number of rows/cob followed by days to maturity, number of kernels/row and cob length. Number

of grains/cob had highest indirect effect on grain yield through number of kernels/row followed by days to maturity through number of kernels/row and number of rows/cob through number of grains/cob. These results are agreed with some researchers such as Swarnalatha and Mohammad (2001), Mohsan *et al.* (2002), Viola *et al.* (2003 and Alam (2009).

At phenotypic level, highly significant undesirable direct effect on grain yield was found for number of grains/cob which is in agreement with the results of Alvi *et al.* (2003), Sofi and Rather (2007) and Alam (2009); but contrary to the results of path analysis which in their research found Akbar *et al.* (2008) and Najeeb *et al.* (2009).

Path coefficient values based on phenotypic correlation revealed that most of traits except cob length had direct positive effect towards grain yield also having positive correlation with grain yield. Therefore, proper attention should be given to the above characters for the improvement of grain yield. These results are in agreement with the results of many authors (Alvi *et al.*, 2003; Sumathi *et al.*, 2005; Sofi and Rather, 2007; Najeeb *et al.*, 2009 and Alam, 2009).

In the present study, path coefficient analysis suggests that during selection more emphasis should be given on cob length, number of rows/cob, number of kernels/row and number of grains/cob. Since these characters, had high correlation and high direct effect on grain yield. Nemati *et al.* (2009) reported that ear weight had direct effect on grain yield.

SELECTION INDEX

Different selection indices were formulated using different combinations of grain yield and yield contributing characters and their expected genetic gain were estimated (Table 4.1.16). It was observed that among all the selection indices, the index based on cob height + number of rows/cob + number of

kernels/row + grain yield/plant had the maximum genetic gain. Among the others, the indices based on cob length+ number of rows/cob + number of kernels/row over straight selection for grain yield alone.

Therefore, improvement of grain yield through these selection indices is suggested. There are scarcity papers of selection index in maize. More or less similar results were also reported by Paul *et al.* (1978) in mustard. Similar opinions were also reported by Singh *et al.* (1999) in maize and Mondal (2003) in potato.

Bergele *et al.* (2002) suggested that the number of spikes per plant, grains per spike and harvest index must be given preference in selection along with optimum plant height and days to flowering to select the superior wheat genotypes. Similar opinions were also reported by Ferdous *et al.* (2010) in wheat.

Shiv *et al.* (2008) suggested that number of tillers per plant, numbers of spikelets per ear, number of grains per ear, grain weight per ear, 100-grains weight and biological yield could form effective selection indices for selection of high yielding genotypes of wheat.

GENETIC DIVERGENCE

Clustering pattern of inbred lines showed considerable genetic diversity among themselves by occupying five different clusters. Cluster analysis revealed that the 25 maize inbred lines could be grouped into 5 different clusters of which maximum number of inbreeds (each containing 6 inbreeds) was included in cluster I, II and IV. Cluster III had only three lines and that was the lowest. Similar opinions were also reported by Singh *et al.* (2005) in maize and Alam (2009) in maize inbred lines.

The maximum inter-cluster divergence (Table 4.1.17) was observed between the clusters I and II and it was minimum inter-cluster divergence between clusters III and IV. The maximum intra-cluster distance was observed in cluster III and minimum in cluster V. The crosses involving parents from most divergent clusters are expected to manifest maximum heterosis and generate wide variability in genetic architecture.

Intra-cluster distance was much lower than the inter-cluster one, suggesting, heterogeneous and homogeneous nature between and within groups, respectively. This was further supported by an appreciable variation observed for cluster means (Table 4.1.18). Similar results were reported by Singh *et al.* (2005), Liu YuAi *et al.* (2006) in maize. Another study was carried out by Chen FaBo *et al.* (2007) who reported that 186 maize genotypes could be classified into ten clusters.

Mean values of days to maturity, plant height, and ear height and cob length were highest in cluster II and cob diameter and number of kernels/row in III and grain yield in cluster V.

A wide range of variations for several characters among the multi genotypic cluster was observed. However, the difference was clear for plant height, cob length, cob diameter, number of kernels/row and grain yield, which contributed largely to the total divergence. Similar results have also been reported by Singh *et al.* (2005) and Chen FaBo *et al.* (2007). Hence, for the improvement of different characters *viz.* cob length, cob diameter, number of kernels/row, grain number and grain yield under the present study, inbred lines should be selected from clusters II, III and V.

The principal component analysis revealed that in major vector I the important characters responsible for genetic divergence in the major axis of differentiation were days to tasseling, days to silking, plant height, ear height and cob length, cob diameter, number of kernels/cob and grain yield/plant

(Table 4.1.19). In vector II, which was the second axis of differentiation, the characters like days to tasseling, plant height, cob diameter, number of rows/cob, number of kernels/cob and grain yield were important.

The role of plant height, days to tasseling and silking, cob length and diameter, number of kernels/cob and grain yield/plant for both the vectors was positive across two axis which is the indication of the important components of genetic divergence in this material. Similar results have been reported in maize by Singh *et al.* (2005), Chen FaBo *et al.* (2007) and Azad *et al.* (2012).

Clustering D^2 -statistics is useful in this matter. The inbred lines grouped together are less divergent than the ones which fall into different clusters. In selecting lines from the already chosen groups, other important characteristics like disease resistance, earliness, quality or even performance of particular character should also be considered.

DIALLEL AND COMBINING ABILITY

The combining ability of inbred lines is the ultimate factor determining future usefulness of the lines for hybrid development. In the present study, the combining ability of the inbred was assessed for grain yield and important yield contributing characters in a six inbreds diallel cross.

The results of this study showed that the expression of all these characters studied was found to be controlled by both additive and non-additive genes. Griffing analysis of variances for diallel crosses showed significant GCA and SCA mean squares for most of the traits (Table 4.2.14) which is an indication of the importance of both additive and non-additive genetic effects. This result is in agreement with the results of Ahmed and Salem (2003), Glover *et al.* (2005), Uddin *et al.* (2008), Alam (2009) and Afshar and Bahram (2012). Parents P₅ and P₄ exhibited significant positive GCA effects for number of grains/cob and grain yield, but parent P₂ showed negative GCA effect. Therefore, parent P₅ could be a donor parent for yield and earliness in

hybridization programme. The parent P₁ showed significant negative GCA effect for days to maturity and cob height.

Gichuru *et al.* (2011) evaluated different maize inbred lines for days to silking and introduced VHCY with the highest significantly negative (-3.194) GCA effect as the best combiners for earliness.

Roy *et al.* (1998), Debnath *et al.* (1988), Zelleke (2000), Choudhary *et al.* (2000), Desai and Singh (2001), Dubey *et al.* (2001), Hussain *et al.* (2003) and Uddin *et al.* (2008) found two and one inbred lines of maize, respectively, as well as a good general combiner of earliness in two separate experiments. Thus, the inbred lines which exhibited good general combining ability for at least one character can be used for development of early maturity and high grain yield. So, these three parents could be used extensively in hybrid breeding program with a view to increasing the yield level. Similar results have been reported in maize by earlier workers (Beck *et al.*, 1990; Das and Islam, 1993; Odongo and Bockholt, 1995; Spaner *et al.*, 1996; Preciado *et al.*, 1997; Dahlan *et al.*, 1997; San-vicente *et al.*, 1998; Zhao, 1999; Lemos *et al.*, 1999; Desai and Singh, 2001; Uddin *et al.*, 2008; Alam *et al.*, 2008 and Alam, 2009). However, additive genetic effects were preponderance for the expression of days to silking and days to maturity, plant height, ear length and ear girth, number of kernels/ear and 1000-kernel weight.

More importance of additive gene action for these attributes has been reported by Crossa *et al.* (1990), Mahajan and Khehra (1991), Pal and Prodhan (1994), Das and Islam (1994), Altinbas (1995), Odongo and Bockhot (1995), Tulu and Ramachandrappa (1998), Roy *et al.* (1998), Paul and Debnath (1999) and Zelleke (2000).

On the contrary, predominance of non-additive type of gene action for these characters has also been reported earlier (Alika, 1994; El-Hosary *et al.*, 1994; Dehghanpour *et al.*, 1996; Singh and Singh, 1998 and Suneetha *et al.*, 2000). The results of present study elucidated that for grain yield, number of rows/cob,

and cob diameter, non-additive gene action was more important in controlling their expression. Similar gene effect for these characters has been reported by El-Hosary *et al.* (1994), Pal and Prodhan (1994), Mostafa *et al.* (1996), Kim and Ajla (1996), Dehghanpour *et al.* (1996), Joshi *et al.* (1998), Roy *et al.* (1998), San-Vicente *et al.* (1998), Singh and Singh (1998), Ramech *et al.* (2000), Zelleke (2000) and Alam (2009).

However, the results differed from the findings of earlier reports (Das and Islam, 1994; Ferrao *et al.*, 1994; Szatmari, 1996; Tulu and Ramachandrappa, 1998; Mathur *et al.*, 1998 and Choukan, 1999) where additive gene effects were of major contributor for these characters.

For days to maturity and silking, additive gene action was important which is in conformity with the works of Pal and Prodhan (1994) and Zelleke (2000) as they showed a greater influence of additive component of gene action in the expression of maturity. In general, the crosses showing significant specific combining ability (SCA) effect for different characters also possess high mean performance.

In this study, P₁xP₂, P₂xP₅, P₄xP₅ and P₅xP₆ showed positively significant cross combinations were the superior specific combiner for grain yield and other yield components, indicating that most probably the inbred lines involved in producing each one of these crosses belongs to the different heterotic pattern.

It was found that in most of the crosses having the highest mean performance for different characters showed the best or at least good specific combiner in respect of these characters.

Thus, the present results indicate a relationship between mean performance of crosses and SCA effects. However, a few crosses appeared to have high mean value but non-significant SCA effects and vice-versa. Significant positive SCA effect was observed in P₁xP₂, P₁xP₅, P₄xP₅, P₄xP₆ and P₅xP₆ for number of kernels/row. The crosses P₁xP₂, P₁xP₄, P₁xP₅, P₄xP₅, P₄xP₆ and P₅xP₆ showed significantly positive SCA effects for number of grains/cob. Significant

positive SCA represents dominance and epistatic component of variation. This indicated that high *per se* value of cross may not necessarily indicate their potentiality in crosses.

Uddin *et al.* (2006), Uddin (2008), Alam *et al.* (2008) and Alam (2009) reported that any combination among the parents may produce hybrid vigour over the parents which might be due to dominant, over dominant or epistatic gene action. Choudhary *et al.* (2000) observed that SCA effects of the crosses were closely associated with their performance for days to silking and days to maturity. Earlier reporters also identified superior combinations in maize by estimating specific combining ability for different traits (Zelleke, 2000; Choudhary *et al.*, 2000; Desai and Singh, 2001 and Dubey *et al.*, 2001).

From the present study, the inbred parents P₁, P₂, P₄, P₅, and P₆ can be selected for development of high yielding hybrids for their good general combining ability of grain yield and other yield components. Based on mean performance and SCA effects, the crosses P₁xP₂, P₂xP₃, P₄xP and P₅xP₆ were found to be superior. These hybrids can be selected as single cross hybrids for verifying their performance over environments. The importance of GCA compared to SCA for grain yield agrees with previous findings of Kim and Ajala (1996), Ogunbodede *et al.* (2000), Alam *et al.* (2008) and Alam (2009).

In the present study value of F (relative frequencies of dominance and recessive alleles in the parents) for all the characters was positive and greater than zero. It indicates that dominant alleles were more frequent than recessive alleles.

The component D was significant for days to tassel, days to silking, plant height, ear height, number of kernel rows/cob, number of grains/cob and grain yield indicating the importance of additive gene effect in their inheritance.

The component H₁ was highly significant for all the characters which indicate the dominance gene effect in the inheritance of these characters.

The component H_2 was highly significant for all the characters indicating the dominance with asymmetry of positive and negative gene effect in controlling these characters.

Thus highly significant values of the components D, H_1 and H_2 indicated the importance of both additive and dominant gene effect for the characters under study.

The value of h^2 which measures the dominant effect over all loci was non-significant with non-significant environmental variance E for most of the characters.

The environmental component (E) for cob length, cob diameter, days to maturity, number of kernels /cob, number of kernels/row showed lower values indicating less influence of environment and might be less than additive and dominant effects.

Alam (2009) reported that kernels weight was controlled by environmental factors up to 60% in maize. This contradicts with the findings of Debnath and Sarker (1989).

The average degree of dominance $(H_1/D)^{1/2}$ was more than unity for all the characters suggesting the importance of over dominance. Over dominance as well as predominant role non-additive genetic variance in the inheritance of grain yield was reported by Gardner and Lonnquist (1961), Genova (1984), Shahi and Singh (1985) and Genov (1987). Over dominance and predominant genetic variance was observed by Debnath and Sarker (1989) for grain yield, kernel rows per ear and 1000-kernel weight; by Nawar *et al.* (1980) for kernel rows per ear, and by Gamble (1962b) for kernel weight. Gardner and Lonnquist (1959), Johnson (1973), Shahi and Singh (1985), Lin and Chen (1986) and Debnath and Sarker (1989) observed partial dominance for ear length and number of kernels per row. Debnath and Sarker (1989) also showed complete dominance for ear diameter.

The values of $H_2/4H_1$ were smaller than 0.25 for all the characters which indicated that positive and negative alleles were not distributed in equal proportion in the parents. Another values of $[4DH_1]^{1/2} + F/[4DH_1]^{1/2} - F$ was greater than unity for all the characters except grain yield, suggesting asymmetrical distribution of dominant and recessive alleles in the parents for the characters.

Another ratio h^2/H_2 , carried values greater than one indicating many groups of genes were responsible for their genetical control. For grain yield, the presence of an excess of dominant alleles than recessive alleles was observed in the parents.

Almost all the characters were observed to be under polygenic control. However, maximum number of genes or gene groups controlled grain yield. The highest number of genes or gene groups for grain yield was also reported by Debnath and Sarker (1989) and Alam (2009).

The low narrow-sense heritability values indicated that genotypic variance was governed by non-additive gene action. Similar results have been reported in maize by Alam (2009) and Azad *et al.* (2012).

V_r - W_r graphs indicate that it is difficult to attain simultaneous improvement for all the characters, as there is involvement of partial dominance and over dominance. The combined improvement of such characters should be based upon exploitation of both fixable and non-fixable components of genetic variance.

Utilization and exploitation of yield and yield components of maize require a clear understanding of their genetic architecture. A great deal of genetic architecture in maize has been studied which revealed that the nature of inheritance regarding gene action varied from material to material.

Over dominance as well as importance of non-additive gene action in the inheritance of grain yield was observed by Gamble (1962a), Darrah and Hallauer (1972), Genov (1987) and Debnath and Sarker (1989, 1990b). On the

other hand, Lonquist and Castro (1967) and Murthy (1978) reported partial dominance as well as predominant role of additive genetic variance of this trait. Epistasis was also observed in grain yield by Gamble (1962a) and Darrah and Hallauer (1972).

Result of the present study revealed that sufficient genetic diversity existed among the parents, which is essential for the improvement of a crop. Partial dominance or over dominance with non-allelic interaction was observed in most of the characters. For grain yield, over dominance as well as non-allelic interaction in the inheritance was evident.

It has been noticed that expression of dominant and recessive alleles in the parents was influenced by environment as the same parent showed different positions on Vr-Wr graphs.

HETEROSIS

Heterosis is directly proportional to the existence of non-additive (dominance and epistasis) genetic variance in a population. The existence of significant amount of dominance variance is a prerequisite for exploitation of heterosis. Heterosis is also associated with wide adaptability of parents.

The cross having high heterosis coupled with high SCA can be utilized for commercial exploitation of heterosis. For commercial usefulness, economic or useful heterosis also compared for hybrid selection.

Pal and Prodhan (1994) suggested that selection on the basis of specific combining ability for the most useful heterotic crosses and thereafter development of single or double cross hybrid would be more effective in achieving genetic amelioration of maize for grain yield and oil content.

For days to tasseling, $P_1 \times P_2$, $P_1 \times P_3$, $P_1 \times P_4$, $P_1 \times P_5$, $P_2 \times P_3$, $P_2 \times P_4$ and $P_2 \times P_5$ over mid parent and better parent showed significant positive heterotic effect. $P_1 \times P_6$ and $P_5 \times P_6$ crosses over mid parent and better parent showed significant negative heterosis.

For silking, ten crosses over mid parent and eleven crosses over better parent showed significant positive heterosis whereas the crosses $P_2 \times P_6$ and $P_3 \times P_4$ showed significant negative heterosis. For maturity, three crosses over mid parent showed negative and useful heterosis whereas twelve crosses over better parent showed significant positive heterosis in these crosses, $P_3 \times P_6$ showed highest and earliest performance in maturity stage. Negative heterosis for earliness in maize was reported by Vasal *et al.* (1992b), Alam *et al.* (2008) and Alam (2009).

Five crosses for plant height and three crosses for ear height showed significant positive heterosis over mid parent and over better parent. Rest of the crosses in these traits had significant negative heterosis. Cob length and cob diameter are important yield contributing characters of maize inbred lines.

Most of the crosses showed significant negative and useful heterosis over mid parent and over better parent for cob length and diameter. Paul *et al.* (1995) reported significant negative heterosis over high parent in most of the crosses for cob length.

For number of kernels/row, $P_1 \times P_2$, $P_1 \times P_3$ and $P_4 \times P_6$ over mid parent and better parent showed significant positive heterotic effect. $P_1 \times P_6$ and $P_3 \times P_5$ crosses over mid parent and better parent showed significant negative and useful heterosis. Highest significant positive heterosis over mid parent was found by the cross $P_4 \times P_6$ and better parent in $P_4 \times P_5$.

Most of the crosses over mid parent and better parent showed significant heterosis for number of grains per cob. The crosses $P_1 \times P_2$ and $P_1 \times P_5$ respectively showed the highest and significantly positive heterosis over mid parent and over better parent in this trait.

Most of the crosses over mid parent and better parent showed significant negative and useful heterosis for grain yield. Maryam and Jones (1985), Vasal *et al.* (1992b) and Alam (2009) reported that yield is associated with delayed maturity and increased plant height which support the present investigation.

Among the characters studied for grain (kernel) yield and other yield contributing characters, most of the crosses are considered to be the most excellent, as they showed significant negative and useful heterosis.

$P_2 \times P_5$ showed the highest negative heterosis percent (-27.25 and -40.37) for grain weight while 15.30% positive heterosis over mid-parent was recorded for grain yield in $P_1 \times P_2$.

The results revealed that there is enough heterosis for all the characters studied in maize. It is well established that the incidence and magnitude of heterosis have positive association with the presence and magnitude of non-allelic interaction (Singh and Narayanan, 1993). It also indicates the possibility of increasing kernel yield by exploiting heterosis.

The presence of high heterosis indicates genetic diversity among the parents. Similar results have been reported in maize by Alam *et al.* (2008), Uddin *et al.* (2008) and Alam (2009). More importance of additive gene action for days to silking and days to maturity, plant height, ear length and girth, number of kernels/ear and 1000-kernel weight has been reported by Paul and Debnath (1999) and Zelleke (2000).

SUMMARY AND CONCLUSION

In the present investigation, 25 different maize inbred lines were evaluated for eleven quantitative characters *viz.*, days to tasseling, days to silking, days to maturity, plant height, ear height, cob length, cob diameter, number of rows/ear, number of kernels/row, number of kernels/cob and grain yield/plant were selected. Statistical analyses such as mean, partition of components of variation, coefficient of variability, heritability, genetic advance, genetic advance as percentage of mean, correlation coefficient, selection index, genetic divergence through D^2 - statistics, diallel analysis, combining ability and heterosis study were carried out.

An analysis of variance reveals that the item inbred line was highly significant indicating that 25 maize inbred lines were genetically different from each other. The estimates of different components of variation and coefficient of variability, such as phenotypic, genotypic and error were more or less high for days to silking, days to tasseling, number of grains/cob, number of kernels/row and yield, which indicates the wide scope of improvement of these characters through selection. The highest of h^2b was recorded for days to silking, cob diameter and the lowest in number of grains/cob. Genetic advance was highest in plant height and lowest in number of rows/cob. The highest value of GA% was found for cob diameter and the lowest in days to silking.

High values of genotypic coefficient of variation and high heritability estimates coupled with high genetic advance for days to silk, plant height, cob diameter, number of kernels/cob and number of kernels/row suggesting that phenotypic selection of parental inbred lines for hybridization program based on these characters would be effective. Phenotypic coefficient of variation for all the characters was higher than the genotypic coefficient of variation suggesting the more environmental effect on phenotypic complexes.

Grain yield was positively and significantly associated at the genotypic as well as the phenotypic levels with days to maturity, number of kernels/row and number of grains/cob. So, selection on the basis of these characters should get preference for breeding programme.

Path coefficient analysis using genotypic correlation revealed that days to maturity, cob length, number of rows/cob, and number of kernels/row had direct positive influence on grain yield. At the phenotypic level, days to maturity, plant height, ear height, cob length, number of rows/cob, number of kernels/row and grains number showed direct positive effect on grain yield and also positively correlated with grain yield. These results suggest that during selection more emphasis should be given on days to maturity, number of rows/cob and number of kernels/row.

The high expected genetic gains were more frequent through the different sets of data, when more character combinations were studied in the function. Large values for expected gains were obtained when all the four characters were included in a combination. Among the indices, the combinations, cob diameter + number of rows/cob + number of kernels/row + grain yield gave high values for expected gains over all sets of data.

Cluster analysis showed that maize inbred lines could be grouped into five different clusters. The highest inter-cluster distance was observed between I and II and the lowest inter-cluster distance was observed between clusters III and IV. Cluster III had maximum intra-cluster distance. However, the differences were clearer for days to silking, cob diameter, number of kernels/row, number of kernels/cob and grain yield/plant which had contributed largely to the total genetic divergence. Cluster I had the highest mean values for number of kernels/ear, plant height, days to maturity and grain weight/cob; cluster III had highest mean values for number of kernels/cob, plant height and days to maturity. Cluster IV had the highest mean value for days to silking and

days to maturity, cob length and number of kernels/cob. Therefore, for the improvement of maize, inbred lines should be selected from III and IV.

Combining ability analysis was carried out in a half diallel cross among six inbred lines for grain yield and its contributing characters. The expression of all these characters studied was found to be controlled by both additive and non-additive genes. However, additive genetic effects were preponderance for the expression of days to silking and days to maturity, and ear height, cob length and cob diameter, number of kernels/cob and grain weight.

The results of the present investigation elucidated that for grain yield, number of rows/cob, and ear height non-additive gene action was more important in controlling their expression. Thus, the present results indicated that the genetic improvement for the characters having additive genetic effects would be possible through the exploitation of such gene effects and for the characters, the predominance of non-additive genetic variance offered the scope for exploitation of heterosis utilizing such gene action.

Among the inbred lines, P₁, P₂, P₅ and P₆ were found to have good general combiners for grain yield and other yield contributing characters. These inbred lines can be used for the development of high yielding hybrids in maize.

Mean performance of heterotic crosses and SCA effects for different characters showed a good association. Based on *per se* performance and SCA effects, superior cross combinations P₁xP₂, P₁xP₃, P₁xP₅, P₂xP₃, P₂xP₄, P₄xP₅ and P₅xP₆ can be selected as promising single cross hybrids. Among the parents, these crosses P₁xP₂, P₂xP₅, P₄xP₅ and P₅xP₆ were considered to be the most excellent for exploitation of heterosis. After verifying the results of these promising hybrids over environments, good performers can be selected for commercial utilization.

Gene action of parents showed highly significant values of the components D, H_1 and H_2 indicated the importance of both additive and dominant gene effects for the characters under study.

The value of h^2 which measures the dominant effect over all loci was significant with significant environmental variance E for all the characters which suggested the importance of dominance effect. As an indicator of the relative frequency of dominant and recessive alleles in the parents, the F value was found to be positive but significant for most of the characters, which means either that no alleles exhibit dominance or else that the dominant and recessive alleles are distributed equally among the parents.

In this study, the latter alternative may apply since the variances for H_1 and H_2 were significantly different from zero. It may thus be concluded that the dominant and recessive alleles of the related genes are distributed equally among the parents. Since the mean dominance effect of the heterozygote locus (h^2) was significant, high heterotic effect values would be expected for most of the traits among the crosses. The parameters E, an estimate of the genotypic environmental variation and D, the additive genetic variance, were not different from zero.

The parameter D, which may also include a portion of the additive x additive epistatic variances as well as additive genetic variance itself, was significant for grain yield. Dominance variance (H_1) and corrected dominance variance (H_2) were significantly different from zero. It may thus be concluded that grain yield is under the dominance gene effect.

Graphical analysis revealed over dominance gene action for most of the characters, whereas partial dominance gene action was recorded for cob length and cob diameter and number of grains/cob. Partial dominance was indicated for the inheritance of grain yield since the regression line of the W_r/V_r graph cut the

W_r axis above the origin. With regard to grain yield, the parents P₃ and P₆ had more dominant genes whereas P₅, P₄, P₂ and P₆ carried more recessive genes.

The following inferences are made on the basis of overall performance of the maize inbred lines.

- » Additive gene action with partial dominance was found for days to silking and maturity, and cob length and diameter, number of kernels/cob and grain weight under the situations.
- » Over- dominance type of gene action was observed for days to tasseling and plant height.
- » Additive gene action for grain yield, number of rows/cob and cob height changed to over-dominance.
- » The best combinations on the basis of mean performance were P₁xP₂, P₂xP₅, P₄xP₅ and P₅xP₆.
- » Parents P₁, P₂, P₅ and P₆ were found to be best parents. These parents may be exploited in future breeding programs.

IL18 (P₅) had the highest number of kernels/cob and grain yield/plant compared with the other parents and it is considered the best combiner to improve the kernels and grain weight in plants, because it showed the highest positive and significant GCA.

Better performing four crosses (P₁xP₄, P₁xP₅, P₄xP₅ and P₅xP₆) can be utilized for developing high yielding hybrid varieties as well as for exploiting hybrid vigor. These crosses also need to be evaluated through multiplications.

REFERENCES

- Abd El-Sattar, A. A. 2003. Genetic parameters estimation from design-1 and S₁ lines in maize. *Minufiya J. Agric. Res.* 28(5):1387-1402.
- Abd-El-Aty, M. S. and Y. S. Katta. 2002. Correlation and path coefficient analysis for grain yield and its components in some maize hybrids (*Zea mays* L.). *J. Agric. Sci. Mansura Univ.* 27(6): 3697-3705.
- Abirami, S., C.Vanniarajan, S. Arumugachamy and D. Uma. 2007. Correlation and path analysis for morphological and biochemical traits in maize genotypes. *PlantArchives* 7(1):109-113.
- Adel, M. M. and E. A. Ali. 2013. Gene action and combining ability in a six parent diallel cross of wheat. *Asian J. Crop Sci.* 5(1):14-23.
- Agrawal, R. L. 2002. Fundamentals of plant breeding and hybrid seed production. Oxford and IBH Publishing Co. Pvt. Ltd. New Delhi- India. Reprint pp.174-175.
- Ahloowalia, B. S and N. I. Dhawan. 1963. Effect of genetic diversity in combining ability of inbred lines of maize. *Indian J. Genet.* 23:158-162.
- Ahmad. A and M. Saleem. 2003. Path coefficient analysis in *Zea mays* L. *Int. J. Agric. Biol.* 5(3): 245-248.
- Ahmed S. U. and F. Khatun. 2004. Evaluation of locally developed hybrid (Set-1). Annual Res. Report 2003-2004, Plant Breeding Dev. BARI. pp.12-17.
- Ahmed, A. A. 2004. Diallel analysis and stability of yield and yield components in bread wheat (*Triticum aestivum* L. em. Thell). M.Sc. Thesis, Faculty Agriculture Assiut University, Egypt.

- Ahmed, F., K. Saleem, A. Latif, K. Hakim, K. Ayub and N. Akhtar. 2011. Genetics of yield and related traits in bread wheat over different planting dates using daillel analysis. *African J. Agric. Res.* 6:1564-1571.
- Akanda, M. A. L., M. S. Alam and M. M. Uddin. 1997. Genetic variability correlation and path analysis in maize (*Zea mays L.*) inbreds. *Bangladesh J. Pl. Breed. Genet.* 10(1&2):57-61.
- Akanda, M. A. L., M. S. Alam and M. M. Uddin. 1998. Genetic variability, correlation and path analysis in composite maize (*Zea mays L.*). *Bangladesh J. Agril. Res.* 23 (1):107-113.
- Akbar, M., M. S. Shakoor, A. Hussain and M. Sarwar. 2008. Evaluation of maize 3-way crosses through genetic variability, broad sense heritability, characters association and path analysis. *J. Agric. Res.* 46(1):39-45.
- Akhtar, S. A. and T. P. Singh. 1981. Heterosis in varietal crosses of maize. *Madras Agric. J.* 68: 47-51.
- Alam, A. K. M. M., S. Ahmed, M. Begum and M. K. Sultan. 2008. Heterosis and combining ability for grain yield and its contributing characters in maize. *Bangladesh J. Agril. Res.* 33(3): 375-379.
- Alam, M. S. 2009. Studies on genetic and environmental components of variability in maize (*Zea mays L.*) Ph. D Thesis, Dept. of Botany, Rajshahi University, Bangladesh.
- Ali, M. Y., N. C. Roy, R. A. Sarker, M. H. Islam and K. M. Kabir. 1997. Genetic parameter and character association in maize. *Bangladesh J. Pl. Breed. Genet.* 10(1&2): 63-65.
- Ali, M. Y., R. A. Sarker, K. M. Kabir and M. H. Islam. 1994. Estimates of genetic parameters, characters association and path analysis in different maize genotypes. *Bangladesh J. Pl. Breed. Genet.* 7(2): 49-52.

- Alika, J. E. 1994. Genetic variability among S₁ families for grain yield in maize (*Zea mays* L.). Indian J. Genet. 54(1):27-31.
- Aliu, S., Sh. Fetahu and A. Saillari. 2008. Estimation of heterosis and combining ability in maize (*Zea mays* L.) for ear weight (EW) using the diallel crossing method. AGRONOMIJAS VESTIS (Latvia Journal of Agronomy). No. 11. Lu. 2008.
- Allard, R. W. 1962. Relationship between genetic diversity and consistency of performance in different environments. Crop Sci. 1: 127-129.
- Allard, R.W. 1960. Principles of plant Breeding. John Wiley and Sons. Inc. N.Y.
- Altinbas, M. 1995. Heterosis and combining ability in maize for grain yield and some plant characters. Anadolu. 5(2): 35-51.
- Alvi, M. B., M. Rafique, M. S. Tariq, A. Hussain, T. Mahmood and M. Sarwar. 2003. Character association and path coefficient analysis of grain yield and yield components maize (*Zea mays* L.). Pakistan. J. Biol. Sci. 6(2):136-138.
- Amanullah., S. Jehan, M. Mansoor and M. A. Khan. 2011: Heterosis studies in diallel crosses of maize. Sarhad J. Agric. 27(2): 207-211.
- Amin, A. Z., H. A. Khalil and R. K. Hassain. 2003. Correlation studies and relative importance of some plant characters and grain yield in maize single crosses. Arab Univ. J. Agric. Sci. Ain Shams Univ. Cairo. 11(1): 181-190.
- Annapurna, D., K. H. A. Khan and S. Mohammad. 1998. Genotypic, phenotype correlations and path coefficient analysis between seed yield and other associated characters in tall genotypes of maize. Crop Res. 16: 205-209.

- Anonymous. 2003. Bangladesh Bureau of Agricultural Statistics, MOP, Government of the Peoples Republic of Bangladesh. Dhaka, Bangladesh. pp-61.
- Appadurai, R. and R. Nagarajan. 1975. Hybrid vigour in pop corn. J. Madras Agric. Univ. 62:122-126.
- Araujo, P. M. and J. B. Miranda. 2001. Analysis of diallel cross for evaluation of maize populations across environments. Crop Breed. Appl. Biotech. 1:255-262.
- Arha, M. D., R. P. Sarda and K. N. Agarwal. 1990. Studies on maize gene pools. II. Heritability and expected genetic advance. Acta Agronomica Hungarica. 39 (1-2): 121-125.
- Arunachalam, V. 1981. Genetic distance in plant breeding. Indian J. Genet. 41:226-236.
- Aydin, N., S. Gokmen., A. Yildirin., A. Oz., G. Figliuolo and H. Budak. 2007. Estimating genetic variation among dent corn inbred lines and top crosses using multivariate analysis. J. Appl. Biol. Sci. 1(2): 63-70.
- Azad, M. A. K., B. K. Biswas, N. Alam and Sk. S. Alam. 2012. Genetic diversity in maize (*Zea mays* L.) inbred lines. The Agriculturists. 10(1): 64-70.
- Baker. R. 1984. Some of the open pollinated varieties that contributed the most to modern hybrid corn. *In*: Proc. of the 20th Annual Illinois Corn Breeders School. 6-8 May 1984. Univ. of Illinois, Urbana-Champaign. pp. 1-19.
- Banik, B. R. 2008. Studies on the combining ability of maize. Annual Research Report. pp. 12-15.
- Banik, B. R., M. S. Uddin and M. H. Rashid. 2009. Proceedings of the international conference on plant breeding and seed for food security. BARI. Gazipur. pp. 82-88.

- Bantte, K. and B. M. Prasanna. 2004. Endosperm protein quality and kernel modification in the quality protein maize inbred lines. *J. Pl. Biochem. Biotech.* 13: 57-60.
- Bao-Heping, Zhang Jun, Zhao-Lizhi, Yu-Yan Shen and Dou-Maohai. 2004. Path analysis of ear characters in spring inbred maize lines. *J. Jilin Agric. Univ.* 26(1):16-18.
- Basheruddin, M., R. Balakrishna and M. Shaik. 1999. Correlation coefficient and path analysis of component character as influenced by the environments in forage maize. *Crop Res.* 17: 85-89.
- BBS. 2009. Year Book of Agricultural Statistics of Bangladesh, Bangladesh Bureau of Statistics, Ministry of Planning, Dhaka, Bangladesh.
- Beal, W. J. 1980. Indian corn. *Rep. Mich. Board Agric.* 19: 279 – 280.
- Beck, D. L., S. K. Vasal and J. Crossa. 1990. Heterosis and combining ability of CIMMYT's tropical early and intermediate maturity maize (*Zea mays* L.) germplasm. *Maydica* 35(3): 279-285.
- Beck, D. L., S. K. Vasal and J. Crossa. 1991. Heterosis and combining ability among subtropical and temperate intermediate-maturity maize germplasm. *Crop Sci.* 31:68 –73.
- Bekavac, G., B. Purar and D. Jockovic. 2008. Relationship between line *per se* and testcross performance for agronomic traits in two broad-based populations of maize. *Euphytica* 162:363-369.
- Bekavac, G., B. Purar, M. Stojakovic, D. Jockovic, M. Ivanovic and A. Nastasic. 2007. Genetic analysis of stay-green traits in broad-based maize populations. *Cereal Res. Comm.* 35(1):31-41.
- Bello, O. B., S. Y. Abdulmalik, M. S. Afolabi and S. A. Ige. 2010. Correlation and path coefficient analysis of yield and agronomic characters among open pollinated maize varieties and their F₁ hybrids in a diallel cross. *African J. Biotechnol.* 9(18): 2633-2639.

- Bergale. S., M. Billore, A. S. Holkar, K. N. Ruwali and S. V. S. Prasad. 2002. Pattern of variability, character association and path analysis in wheat (*Triticum aestivum* L.). *Agric. Sci. Dig.* 22(4): 258-260.
- Bhalla, S. K., S. Bali, S. Sharma and B. K. Sharma. 1986. Assessment of genetic variability and correlation in indigenous maize (*Zea mays* L.) germplasm of Himachal Pradesh. *Himachal J. Agril. Res.* 12:75-81.
- Bhalla, S. K., S. J. Sefvi and B. K. Sharma, 1979. Heterosis in inter-varietal crosses in maize. *Indian J. Genet.* 39: 415- 418.
- Bhiote, K. D., S. R. Pardeshi and B. M. Mhaske. 2007. Correlation and path analysis studies in forage maize. *Agric. Sci. Dig.* 27(2): 146-147.
- Bocanski, J., Z. Sreckov and A. Nastasic. 2009. Genetic and phenotypic relationship between grain yield and components of grain yield of maize (*Zea mays* L.). *Genetica* 41(2):145-154.
- Boraneog, S. and P. K. Duara. 1993. Phenotypic performance and correlation in maize. *Indian J. Agric. Sci.* 6: 29-33.
- Burton, G. M. 1952. Quantitative inheritance in grass pea. *Proceeding of the 6th International Grassland Congress.* 1: 277-283.
- Burton, G. W. and E. M. Devane. 1953. Estimating heritability in fall fescue (*Festuca cirnelinaceae*) from replicated clonal material. *Agron. J.* 45: 479-481.
- Chaguale, D. S. 1967. Discriminant function and its use in crop improvement. *Poona Agric. Coll. Mag.* 57:29-32.
- Chaudhary, A. K., L. B. Chaudhary and K. C. Sharma. 2000. Combining ability estimates of early generation inbred lines derived from two maize populations. *Indian. J. Genet. Plant Breed.* 60(1): 55- 61.
- Chen FaBo., Yang KeCheng, Rong TingZhao and Pan GuangTang. 2007. Analysis of genetic diversity of maize hybrids in the regional tests of Sichuan and Southwest China. *Acta Agronomica Sinica.* 33(6): 991-998.

- Choukan, R. 1999. General and specific combining ability of ten maize inbred lines for different traits in diallel crosses. *J. Seed Sci.* 15 (3): 280-295.
- Comstock, K. and P. R. Robinson. 1952. Estimation of genetic advance. *Indian J. Hill.* 6(2):171-174.
- Crossa, J. 1990. Statistical analyses of multilocation trials. *Advances in Agronomy.* 44:55-85.
- Crossa, J., S. K. Vasal and D. L. Beck. 1990. Combining ability estimates of CYMMIT tropical late yellow maize germplasm. *Maydica* 35(3):273-278.
- Cruz, C. D. and P. C. S. Carneiro. 2003. Modelos biométricos aplicados ao melhoramento genético. Editora UFV. Viçosa. p.585
- Dahlan, M., M. J. Mejaya, S. Slamet, Mudjiono and F. Kasim. 1997. Combining ability among S2 lines derived from two late maize populations. *Indonesian J. Crop Sci.* 12(1-2):1-6.
- Darrah, L. L. and A. R. Hallauer. 1972. Genetic effects estimated from generation means in four diallel sets of maize inbreds. *Crop Sci.* 12:615–621.
- Das, U. R. and M. H. Islam. 1994. Combining ability and genetic studies for grain yield and its components in maize (*Zea mays* L.). *Bangladesh J. Plant Breed. Genet.* 7(2):41-47.
- Das, U. R. and M. H. Islam. 1993. Genetics of kernel weight in maize (*Zea mays* L.). *Bangladesh J. Plant Breed. Genet.* 6(2): 53-57.
- Dass, S., V. P. Ahuja and M. Singh. 1997. Combining ability for yield in maize. *Indian J. Genet.* 57: 98–100.
- Datu, H. 1998. Phenotypic and genotypic correlations between vegetative period and grain yield and other agronomic trait in early maize. *Analeta Institutului Ceretari pentru Cerela Si Plante Technice Fundulea.* 65: 101-109.

- Davis, R. L. 1927. Report of the plant breeder. Rep. Puer to Rico. Agric. Exp. Sta. pp: 14-15.
- Debnath, S. C. 1984. Heterosis in maize: I. Grain yield and some of its attributes. Bangladesh J. Agric. Res. 9:78-83.
- Debnath, S. C. 1987. Heterosis in maize (*Zea mays* L.). Bangladesh J. Agric. Res. 12: 161-168.
- Debnath, S. C. 1989. Heterosis in maize for grain yield, maturity characters, plant height and ear height. : I. Grain yield and some of its attributes. Bangladesh J. Agric. Res. 13: 17-24.
- Debnath, S. C. and K. R. Sarker 1989. Variance components analysis of six quantitative characters in maize. Bangladesh J. Pl. Breed. Genet. 2(1&2):13-17.
- Debnath, S. C. and K. R. Sarker. 1990b. Genetic analysis of grain yield and some of its attributes in maize. Bangladesh J. Agric. Res. 15:64-69.
- Debnath, S. C., K. R. Sarker and D. Singh. 1988. Combining ability estimates in maize (*Zea mays* L.). Ann. Agric. Res. India. 9(1): 37-42.
- Debnath, S. G. and M. F. Khan. 1991. Genotypic variation, covariance and path analysis in maize. Pakistan J. Sci. Indust. Res. 34: 391-394.
- Dehghanpour, Z., B. Ehdai, M. Moghaddam, B. Griffing and B. I. Hayman. 1996. Diallel analysis of agronomic characters in white endosperm corn. J. Genet. Breed. 50(4): 357-365.
- Desai, S. A. and R. D. Singh. 2001. Combining ability studies for some morphological and biochemical traits related to drought tolerance in maize (*Zea mays* L.). Indian J. Genet. 61(1): 34-36.
- Devi. B., N. S. Barua and P. Talukar. 2007. Analysis of mid parent heterosis in a variety diallel in rainfed maize. Indian J. Genet. Plant Breed. 67(2):67-70.
- Dewey, D. R and K. H. Lu. 1959. A correlation and path coefficient analysis of components crested wheat grass seed production. Agron. J. 51:515-518.

- Dias, D. 2005. Milho. *In: Agriannual*. FNP, São Paulo. pp. 409-410.
- Dubey, R. B., V. N. Joshi and N. K. Pandiya. 2001. Heterosis and combining ability for quality, yield and maturity traits in conventional and non-conventional hybrids of maize (*Zea mays* L.). *Indian J. Genet.* 61(4): 353-355.
- Dutu, H. 1999. Results concerning the genetic determinism of maize productivity. *Circetari Agronomice-in-Moldova*. 32: 29-33.
- East. E. M. 1908. Inbreeding in corn. *Connecticut Agric. Expt. Sta. Rep.* 1907. pp. 419-427.
- El-Borhamy, H. S. 2004. Genetic analysis of some drought and yield related characters in spring wheat varieties (*Triticum aestivum* L. em.Thell). *J. Agric. Sci. Mansoura Univ.* 29:3719-3729.
- El-Hosary, A. A., M. K. Mohamed, S. A. Sedhom and G. K. A. Abo-el-Hassan. 1994. General and specific combining interaction with year in maize. *Ann. Agri. Sci. Moshtohor.* 32:217-218.
- El-Hosary, A. A., M. K. Mohamed, S. A. Sedhom and G. K. A. Abo-El-Hassan. 1994. Performance and combining ability in diallel crosses of maize. *Ann. Agri. Sci.* 32 (1): 203-215.
- El-Shouny, K. A., O. H. Ei-Bagowly, K. I. M. Ibrahim and S. A. Ai-Ahmad. 2005. Correlation and path analysis in four yellow maize crosses under two planting dates. *Arab Univ. J. Agric. Sci.* 13(2): 327-339.
- Estakhr, A. and B. Heidari. 2012. Combining ability and gene action for maturity and agronomic traits in different heterotic groups of maize inbred lines and their diallel crosses. *J. Crop Sci. Biotech.* 15(3):219-229.
- Falconer, D. S. 1981. *Introduction for quantitative genetics*, 4th Edition, Oliver and Boyd, Edinburg, London. p.316.
- Falconer, D. S. and T. F. C. Mackay. 1996. *Introduction to quantitative genetics*. 6th ed. Longman, London.

- FAO. 2009. Yearbook production, Food and Agriculture Organization, Rome of the United Nations. 62: 78.
- Fehr, W. R. 1987. Principles of cultivar development: Vol.1: Theory and technique. New York, USA. Macmillan Publishing Company.
- Ferdous, M. F., A. K. M. Shamsuddin, D. Hasan and M. M. R. Bhuiyan. 2010. Study on relationship and selection index for yield and yield contributing characters in spring wheat. J. Bangladesh Agril. Univ. 8(2):191-194.
- Ferrao, R. G., E. E. G. E. Gama, H. W. L. Decarvalho and M. A. G. Ferrao. 1994. Evaluation of the combining ability of twenty maize lines in a partial diallel cross. Pesquisa Agropecuaria Brasileira. 29(12):1933–1939.
- Fisher, R. A. 1918. The correlation between relatives on the supposition of Mendelian inheritance. Trans. Royal Soc. Edinburgh. 52: 399–433.
- Fisher, R. A. 1925. Statistical methods for research workers. Oliver & Boyd, London.
- Fisher, R. A. 1936. The use of multiple measurements in taxonomic problems. Ann. Eugen. 7:179-189.
- Gamble, E. E. 1962a. Gene effect in corn (*Zea mays* L.). I. Separation and relative importance of gene effects for yield. Can. J. Plant Sci. 42: 339 – 348.
- Gamble, E. E. 1962b. Gene effect in corn (*Zea mays* L.). II. Relative importance of gene effects for plant height and certain component attributes of yield. Can. J. Plant Sci. 42: 349 – 350.
- Garcia Del Moral, L. F., Y. Rharrabti, D. Villegas and C. Roy. 2003. Evaluation of grain yield and its components in durum wheat under mediterranean conditions. An ontogenic approach. Agron. J. 95:266-274.
- Gardner C. O. and S. A. Eberhart. 1966. Analysis and interpretation of the variety cross diallel and related populations. Biometrics 22: 439-452.

- Gardner, C. O and J. H. Lonquist. 1961. Effect of linkage on genetic variances and estimates of average degree of dominance in corn. *Genetics* 46: 867–868.
- Gardner, C. O. 1963. Estimation of genetic parameters in fertilizing plants and their implications in plant breeding. In: *Statistical Genetics and Plant Breeding*. Hanson W.D. and H.F Robinson (Eds.) NAS –NRC Publ. 982. Washington. pp. 225 – 252. . Evaluation of yield and components in inbred maize lines. I
- Gautam, A. S., I. C. Bhandari and R. K. Mittal. 1998. Phenotypic stability for grain yield in maize. *Ann. Biol. Ludhiana*. 14(1): 63-65.
- Gautam, A. S., R. K. Mittal and J. G. Bhandari. 1999. Correlations and path coefficient analysis in maize (*Zea mays* L.). *Ann. Agric. Biotechnol. Res.* 4: 169-171.
- Geetha, K. and N. Jayaraman. 2000. Path analysis in maize (*Zea mays* L.). *Agric. Sci. Dig.* 20: 60-61.
- Genov, M. 1987. Inheritance of quantitative characters in maize and variability of the genetic parameters. VII. 1000-kernel weight, yield and productivity of diploid and tetraploid hybrids diverse in earliness. *Genet. Sci.* 20: 232-239.
- Genova, I. 1984. Combining ability and some genetic features of inbred maize lines. *Genet. Sci.* 17: 418–425.
- Gerrish, E. E. 1983. Indication from a diallel study for interracial maize hybridization in Corn Belt. *Crop Sci.* 23:1082 –1084.
- Ghaderi, A., M. Shishergar, A. Regai and B. Ehdaie. 1984. Multivariate analysis of genetic diversity for yield and its components in mungbean. *J. American Soci. Horti. Sci.* 104: 728-731.
- Gichuru, L., K. Njorge, J. Ininda and L. Peter. 2011. Combining ability of grain yield and agronomic traits in diverse maize lines with maize streak virus

- resistance for Eastern Africa region, *Agric. Biol. J. North. America.* 2: 432-439.
- Gomma, M. A. M. and A. M. A. Shaheen. 1994. Studies on heterosis and combining ability in maize (*Zea mays* L.). *Egypt J. Agron.* 19(1-2): 65-79.
- Griffing, B. 1956. Concept of general and specific combining ability in relation to diallel crossing system. *Austrelian. J. Bio. Sci.* 9: 463-493.
- Guang Cheng, Xue-Yan and Gou-Sheng Xue. 2002. Path analysis of elite yield components of maize. *J. Maize Sci.* 10(3): 33-35.
- Hailegiorgis, D., M. Mesfin and S. K. Gangwar. 2010. Genetic divergence analysis on some bread wheat genotypes grown in Ethiopia. *I. J. S. N.* 1(1):53-57.
- Hallauer, A. R. and J. B. F. Miranda. 1981. *Quantitative Genetics in Maize Breeding.* Iowa State Univ. Press, Ames, 1A.
- Hallauer, A. R., W. A. Russell and R. K. Lamkey. 1989. *Crop Breeding. In: corn and corn improvement, 3rd edn.* Agron Monogr 18, ASA-CSSA-SSSA, Madison, Wisconsin, USA.469-564 pp.
- Han, G. C., S. K. Vasal, D. L. Beck and E. Elias. 1991. Combining ability of inbred lines derived from CIMMYT maize (*Zea mays* L.) germplasm. *Maydica* 36:57-64.
- Hanson, G. H., H. F. Robinson and R. E. Comstock. 1956. Biometrical studies of yield in segregating populations. *Korean hespedeza. Agron. J.* 48:267-282.
- Harjinder, S., J. S. Chawla and M. S. Grewal. 2006. Correlation and path coefficient analysis on some elite genotypes. *Crop. Improv.* 33(1):31-33.
- Hayman, B. I. 1954a. The theory and analysis of diallel crosses. *Genetics* 39: 789-809.
- Hayman, B. I. 1954b. The analysis of variance of diallel tables. *Biometrics* 10: 235-244.

- Hayman, B. I. 1957. Interactions, heterosis and diallel crosses. *Genetics* 42: 336-355.
- Hayman, B. I. and K. Mather. 1955. The description of genetic interaction in continuous variation. *Biometrics* II: 69 –82.
- Hazel, L. N. 1943. The genetic basis for constructing selection indexes. *Genetics* 28: 476-490.
- Hoque, M., M. Asaduzzaman, M. M. Rahman, S. Zaman and S. A. Begum. 2008. Genetic divergence in maize (*Zea mays* L.). *Bangladesh J. Agric.* 9:145-148.
- Hussain, M. M. 1997. Genetic study of yield and yield components in chilli (*Capsicum annum* L.). Ph. D. Thesis, I. B. Sc, Rajshahi University.
- Hussain, S. A., M. Amiruzzaman and Z. Hossain. 2003. Combining ability estimates in maize. *Bangladesh J. Agril. Res.* 28(3): 435-440.
- Ivy, N. A., M. S. Uddin, R. Sultana and M. M. Masud. 2007. Genetic divergence in maize (*Zea mays* L.). *Bangladesh J. Pl. Breed. Genet.* 20:53-56.
- Jinks, J. L. 1954. The analysis of continuous variation in a diallel crosses of *Nicotiana rustica* varieties. *Genetics* 39:767–788.
- Jinks, J. L. 1955. A survey of the genetical basis of heterosis in a variety of diallel crosses. *Heredity* 9: 223 – 238.
- Jinks, J. L. and B. I. Hayman. 1957. The analysis of diallel crosses. *Maize Genet. Coop. Newslett.* 27: 48- 54.
- Jinks, J. L. and R. M. Jones. 1958. Estimates of components of heterosis. *Genetics* 43: 128 – 138.
- Joarder, O. I., S. K. Ghose and M. Salehuzzaman. 1978. Genotype-environment interaction in yield and some of its components of *Brassica campestris* L. *Z. Pflanzenzuchtg.* 81: 248-257.
- Johnson, G. R. 1981. Relationship between yield and several yield components in a set of maize hybrids. *Crop Sci.* 13: 649 – 652.

- Johnson, H.W., H. F. Robinson and R. E. Comstock. 1955. Estimates of genetic and environmental variability in Soybean. *Agron. J.* (7): 314 – 318.
- Jones, D. F. 1918. The effects of inbreeding and cross-breeding upon development. *Conn. Agric. Exp. Stn. Bull.* 20:75-100.
- Joshi, V. N., N. K. Pandiya and R. B. Dubey. 1998. Heterosis and combining ability for quality and yield in early maturing single cross hybrids of maize (*Zea mays* L.). *Indian J. Genet.* 58(4): 519 - 524.
- Kalla, V., R. Kumar and A. K. Basandrai. 2001. Combining ability analysis and gene action estimates of yield and yield contributing characters in maize. *Crop Res. Hisar.* 22:102-106.
- Kara, S. M. 2001. Heterosis and line \times tester analysis of combining ability. *Turkish J. Agric. Forestry.* 25: 383-391.
- Khakim, A., S. Stoyanova and G. Tsankova. 1998. Establishing the correlation between yield and some morphological reproductive and biochemical characters in maize. *Rantenie dini Nauki.* 35: 419-422.
- Kim, S. K. 1975. Genotype \times environment interactions of several agronomic traits of maize. *Korean J. Breed.* 7: 163-169.
- Kim, S. K. and S. O. Ajala. 1996. Combining ability of tropical maize germplasm in West Africa. 2. Tropical vs Temperate \times Tropical origins. *Maydica* 41(2): 135-141.
- Kim, S. K., Y. Efron, J. Fajemisin and F. Khadr. 1985. Evolution and progress of hybrid maize project at IITA. *In: Breeding Strategies for Maize Production and Improvement in the Tropics*, Brandolini A and Salamini F (Eds). FAO and Inst. Agron. Per L. Oltermare. Firenze, Italy. pp.369-394.
- Koinuma., Luh, J. R. Severson and R. Bernardo. 2004. Genetic basis of heterosis explored by simple sequence repeat markers in a random-mated maize population. *Theor. Appl. Genet.* 107: 494-502.

- Koirala, K. B and D. B. Gurung. 2002. Heterosis and combining ability of seven yellow maize populations in Nepal. Proceedings of the 8th Asian Maize Workshop, Bangkok, Thailand: August 5-8.
- Konak, C., A. Nay, E. Serter and H. Bayal. 1999. Estimation of combining ability effects, heterosis and heterobeltiosis by line x tester method in maize. *Turki J. Field Crops*. 4: 1-9.
- Krishnan, V. and N. Natarajan. 1995. Correlation and component analysis in maize. *Madras Agric. J.* 82: 391-393.
- Kumar, A. and D. Kumar. 1997. Correlation studies in maize (*Zea mays* L.). *Ann. Soil. Ludiyana*. 13: 271-273.
- Kumar, N. M. V. and S. Kumar. 2000. Studies on characters association and path coefficient for grain yield and oil content in maize (*Zea mays* L.). *Ann. Agric. Res.* 21: 73-78.
- Kumar, P. and E. Satyanarayana. 2001. Variability and correlation studies of full season inbred lines of maize. *J. Res. ANGRAU, Hyderabad, India*. 29:71-75.
- Kumar, S. N. 1999. Comparison of maize growth during short and long duration seasons: G x E interaction. *Ann. Pl. Physiol.* 13(1): 47-53.
- Kumar, S., J. P. Shashi, J. Singh and S. P. Singh. 2006. Correlation and path analysis in early generation inbreds of maize (*Zea mays* L.). *Crop Improv.* 33(2): 156-160.
- Kumar. A. and N. N. Singh. 2004. Identification of yield contributors through path analysis in maize. *Ann. Agric. Res.* 25(3): 448-450.
- Lemos, M. A., E. E. Gomes e Gama, S. N. Parentom, A. C. de. Oliveira, FiB. Reifschneider, J. P. O. Santos, I. N. Tabosa and A. C. de Oliveira. 1999. General and specific combining ability in single hybrids of sweetcorn. *Ciencia e Agrotecnologia*. 23(1): 48-56.

- Leon, C. D. and S. K. Vasal. 2000. Current status and strategy for promoting hybrid maize technology. Training course handouts and material on hybrid technology and seed production in maize, February, 22 – 26, 2000. BRAC Centre, Gazipur, Bangladesh.
- Lin, S. F. and C. Chen. 1986. Studies on combining ability for major agronomic characters in maize (*Zea mays* L.). J. Agric. Assoc. China. 136: 6-14.
- Lonnquist, J. H. and C. O. Gardner. 1961. Heterosis in inter-varietal crosses in maize and its implication in breeding procedure. Crop Sci. 1:179-183.
- Lonnquist, J. H. and G. H. Castro. 1967. Relation of intra-population genetic effects to performance on S₁ lines of maize. Crop Sci. 7: 361- 364.
- Lou, Xing Yang, Zhang Quan De, Yu Zhang Liang and Zhao Junhua. 1998. A study of the genetic effects of maize ears and related traits. Zhejian Nongye Texue. 1: 21-24.
- Lush, J. L. 1949. Animal breeding plans. Iowa State Univ. Press Amres. Int. Proc. American Society of Animal Protection. 33:293-301.
- Mahajan, V. and A. S. Khehra. 1991. Inheritance of quantitative traits in maize (*Zea mays* L.) in winter and monsoon season. Indian J. Genet. 51(3): 292-300.
- Mahalanobis, P. C. 1936. On the generalized distance is statistics. Proc. Natl Acad. Sci. Indian. 12: 49-55.
- Maharajan, V., A. Khehra, B. S. Dhillon and V. K. Sharma. 1990. Inter relationship of yield and other traits in maize in monsoon and winter season. Crop Improv. 17:128- 132.
- Mahmoud, I. M., M. A. Rashid, E. M. Fahmy and M. H. Abo-Dheaf. 1990. Heterosis, combining ability and types of gene action in a 6×6 diallel of maize. Ann. Agric. Sci.Cairo. Special issue: 307-317.

- Malhotra, V. V. and A. S. Khehra. 1986. Genotypic variation and co-variation in indigenous germplasm of maize. *Indian J. Agric. Sci.* 56: 811-816.
- Malik, S. I., H. N. Malik, N. M. Minhas and M. Munir. 2004. General and specific combining ability studies in maize diallel crosses. *Int. J. Agri. Biol.* 6(5): 856-859.
- Mani, V. P. and G. S. Bisht. 1996. Genetic variability in local maize (*Zea mays* L.) germplasm of uttar Pradesh hills. *J. Hill Res.* 9(1): 131-134.
- Mani, V. P., N. P. Gupta, G. S. Bisht, R. Singh and R. Singh. 2000. Genetic variance and heritability of some ear traits in prolific maize (*Zea mays* L.). *Crop Res. Hisar. India.* 20:217-220.
- Maryam, B. and D. A. Jones. 1985. The genetics of maize (*Zea mays* L.) growing at low temperatures II. Harvesting time number of kernels and plant height at maturity. *Euphytica* 34: 475-482.
- Mather, K. 1955. The genetical basis of heterosis. *Proc. Royal. Soc. London* 144: 143 – 159.
- Mather, K. and J. L. Jinks. 1971. *Biometrical Genetics*. 2nd Edn, Chapman and Hall Ltd, London.
- Mather, K. 1949. *Biometrical Genetics* (1st ed.). Mathuen and co Ltd. London
- Mathur, R. K., S. K. Chunilal and V. Singh. 1998. Combining ability for yield, phenological and ear characters in white seeded maize. *Indian J. Genet.* 58 (2):177-182.
- Mian, M. A. K. 1985. Heterosis, inbreeding depression and combining ability analysis in chickpea (*Cicer arietinum* L.) Ph. D. Thesis, Division of Genetics. IARI, New Delhi. pp.129.
- Mian, M. A. K and P. N. Bahl. 1989. Genetic divergence and hybrid performance in chickpea. *Indian J. Genet.* 49:119-124.

- Miller, P. A., J. C. Williams, H. F. Robinson and R. E. Comstock. 1958. Estimates of genetic and environmental variance and covariance and their implication in selection. *Agron. J.* 50:126-131.
- Ming Kai-jian, HUANG Ai-hua, WU Yong-sheng, TAN Hua, CHEN Guo-pin. 2004. Combining ability and cluster analysis of tropical and subtropical maize inbred lines from different genetic resources. ZHENG De-bo. Guangxi Maize Research Institute, Mingyang, Nanning-530227, China. .pp. 225-227.
- Misevic, D. 1990. Genetic analysis of crosses among maize populations representing different heterotic pattern. *Crop Sci.* 30: 997–1001.
- Mohammadia S. A., B. M. Prasanna and N. N. Singh. 2003. Sequential path model for determining interrelationship among grain yield and related characters in maize. *Crop Sci.* 43:1690-1697.
- Mohan, Y. C., K. Singh and N. V. Rao. 2002. Path coefficient analysis for oil and grain yield in maize genotypes. *Natl. J. Pl. Improv.* 4(1): 75-77.
- Mohiuddin, M. 2003. Efficiency and sustainability of maize cultivation in an area of Bangladesh. M. S Thesis. Department of Agricultural Economics, BAU, Mymensingh. pp. 1-7.
- Mohsan, Y. C., K. Singh and N. V. Rao. 2002. Path coefficient analysis for oil and grain yield in maize genotypes. *Natl. J. Pl. Improv.* 4(1): 75-76.
- Mondal, M. A. A. 2003. Improvement of Potato (*Solanum tuberosum* L.) through hybridization and *invitroculture* technique. Ph. D. Thesis, Rajshahi University, Rajshahi, Bangladesh.
- Moniruzzaman, M., R. Karim, Q. M. Alam and M. S. Rahman. 2007. Technical efficiency of maize growers in some selected areas of Bangladesh. Project Report 2006-2007. Economics Division, BARI. Gazipur-1701. pp1-7.

- More, A. J., K. D. Bhoite and S. R. Pardeshi. 2006. Genetic diversity studies in forage maize (*Zea mays* L.). Res. Crops. 7(3): 728-730.
- Mostafa, M. A. N., A. A. A. El-Aziz, G. M. A. Mahgoub and H. Y. S. El-Sherbiney. 1996. Diallel analyses of grain yield and natural resistance to late wilt disease in newly developed inbred lines of maize. Bullet. Facul. Agric. Univ. Cairo. 47(3): 393-403.
- Muhammad, Y. and S. Muhammad. 2002. Estimates of heritability for some quantitative characters in maize. Int. J. Agric. and Biol. 4: 103-104.
- Murthy, A. R. 1978. Genetic analysis of some quantitative characters in maize (*Zea mays* L.). M. Sc. Thesis, College of Agriculture, Dharwar, India.
- Murty B. R. and V. Arunachalam. 1966. The nature of divergence in relation to breeding system in crop plants. Indian J. Genet. 26A:188-198.
- Muthiah, A. R. 1989. Genetic analysis and inheritance of sorghum downy mildew resistant in maize (*Zea mays* L.). Ph. D. Thesis, Tamil Nadu Agric. Univ. Coimbatore.
- Najeeb, S., A. G. Rather, G. A. Parray, F. A. Sheikh and S. M. Razvi. 2009. Studies on genetic variability, genotypic correlations and path coefficient analysis in maize under high altitude temperate ecology of Kashmir. MNL: 46.
- Nastasic, A., D. Jockovic, M. Vanovic, M. Stojakovic, J. Bocanski, I. Dalovic and Z. Sreckov. 2010. Genetic relationship between yield and yield components of maize. Genetika 42(3): 529-534.
- Naveed, A. 1989. Genetic analysis of yield and economic characters in maize diallel crosses. M.Sc. Thesis, Department of Plant Breeding and Genetics, University of Agriculture Faisalabad, Pakistan.

- Nawar, A. A., A. A. A. Naas and M. F. Gomaa, 1981. Heterosis and general vs specific combining ability among inbred lines of corn. *Egypt J. Genet. & Cytol.* 10:19–29.
- Nawar, A. A., A. I. Fahmi and S. A. Salma. 1999. Genetic analysis of yield components and callus growth characters in maize (*Zea mays* L.). *J. Genet. Pl. Breed.* 53:119-127.
- Nawar, A. A., M. I. Gomaa and M. S. Rady. 1980. Heterosis and combining ability in maize. *Egypt J. Genet. Cytol.* 9: 255–267.
- Nemati. A., M. Sedghi., R. S. Sharifi and M. N. Seiedi. 2009. Investigation of correlation between traits and path analysis of corn (*Zea mays* L.) grain yield at the climate of Ardabil region (Northwest Iran). *Not. Bot. Hort. Agrobot. Cluj.* 37(1):194-198.
- Netaji, S. V. S. R. K., E. Satyanarayana and V. Suneetha. 2000. Heterosis studies for yield and yield component characters in maize (*Zea mays* L.). *Andhra Agric. J.* 47: 39-42.
- Odongo, O. M. and A. J. Bockholt. 1995. Combining ability analysis among Kenyan and CIMMYT maize germplasm mid-altitude zone of Kenya. *East African Agric. Forest. J. (Kenya).* 61(2): 171-178.
- Ogunbodede, B. A., S. R. Ajibade and S. A. Olakojo. 2000. Heterosis and combining ability for yield and yield related characters in some Nigerian local varieties of maize (*Zea mays*). *Moor J. Agric. Res.* 1(1): 37-43.
- Ojo, G.O.S., D. K. Adedzwa and L. L. Bello. 2007. Combining ability estimates and heterosis for grain yield and yield components in maize (*Zea mays* L.). *J. Sustainable develop. Agric. Environ.* 3: 49-57.
- Onay, A., H. Basal and C. Konak. 2004. Inheritance of grain yield in a half-diallel maize population. *Turki. J. Agric.* 28: 239-244.

- Ordas, A. 1991. Heterosis in crosses between American and Spanish populations of maize. *Crop Sci.* 31: 931–935.
- Pal, A. K. and H. S. Prodhan. 1994. Combining ability analysis of grain yield and oil content along with some other attributes in maize (*Zea mays* L.). *Indian J. Genet.* 54 (4): 376-380.
- Parihar, A. K., S. L. Godawat, K. B. Shukla and C. M. Parihar. 2012. Combining ability analysis of newer inbred lines derived from national yellow pool for grain yield and other quantitative traits in maize (*Zea mays* L.). *Indian J. Agric. Sci.* 82(5): 416-421.
- Paroda, R. S. and A. B. Joshi. 1970. Correlation, path- coefficient and the implementation of discriminant function for selection in wheat (*Triticum aestivum*). *Heredity* 25: 383-392.
- Patel, D. A., J. S. Patel, M. M. Bhatt and H. M. Bhatt. 2005. Correlation and path analysis in forage maize (*Zea mays* L.). *Res. Crops.* 6(3): 502-504.
- Patil, S. J., R. T. Swamy and A. Ramamurthy. 1972. Genetic variation, heritability and genetic advance of quantitative characters in maize. *Genetica Polonica.* 13:181-184.
- Paul, K. K. and S. C. Debnath. 1999. Combining ability analysis in maize (*Zea mays* L.). *Pakistan J. Sci. Indus. Res.* 42 (3): 141-144.
- Paul, K. K., A. K. Paul and S. R. Bhuiyan. 1995. Heterosis and genetic variability in maize (*Zea mays* L.). *Bangladesh J. Plant Breed. Genet.* 8 (1&2): 11-14.
- Paul, N. K., O. I. Joarder and A. M. Eunos. 1978. Correlation studies and the application of discriminant function selection in Indian mustard. *Acta Agronomica.* 27: 424-428.

- Preciado, E., A. Terron, H. Cordova, H. Mickelson and R. Lopez. 1997. Yield related traits for the selection of early hybrids in subtropical maize. *Agronomia Mesoamericana*. 8(1): 35-43.
- Probecky, O. 1976. Yield and its components in newly bred high yielding maize grain hybrids. *Rostlinna Vjroba*. 22: 1021-1027.
- Prodhan, H. S. and R. Rai. 2000. Character association in pop corn. *Indian Agriculturist*. 44(1/2): 101-103.
- Rafiq, C. M., M. Rafique, A. Hussain and M. Altaf. 2010. Studies on heritability, correlation and path analysis in maize (*Zea mays* L.). *J. Agric. Res.* 48(1):35-38.
- Rafique, M., A. Hussain, T. Mahmood, A.W. Alvi and M. B. Alvi. 2004. Heritability and interrelationships among grain yield and yield components in maize (*Zea mays* L.). *Int'l. J. Agric. & Biol.* 6(6): 1113-1114.
- Rahman, M. M., M. R. Islam, M. K. Sultan and B. Mitra. 1995. Correlation and path coefficient in maize (*Zea mays* L.). *Sci. Indust. Res.* 30: 87-92.
- Rai, B. 1979. Heterosis breeding. *Agrobiological publications*, Delhi-I 1005.1, India.
- Ram. J and D. V. S. Panwar. 1970. Interspecific divergence in rice (*Oryza sativa* L.). *Indian J. Genet.* 30:11-2.
- Ramech, V., A. Rezai, and A. Arzani. 2000. Estimates of genetic parameters for yield and yield components in corn inbred lines using diallel crosses. *J. Sci. Tech. Agric. Natural Res.* 4 (2): 95-104.
- Rao, C. R. 1952. *Advanced Statistical Methods in Biometrics Research*. (1st eds). John Wiley and Sons, New York. pp: 390.
- Rashid, M. H., B. R. Banik and M. S. Uddin. 2010. Proceeding of the tenth Asian regional maize workshop. *Annual Res. Report. 2003-2004*, Plant Breeding Dev. BARI. pp.30-35.

- Reddy, D. M., V. P. Ahuja and B. K. Mukherjee. 2004. AMMI analysis for grain yield stability of maize hybrids. *Ann. Agric. Res.* 25: 218-222.
- Reddy, K. H. E. and B. D. Agarwal. 1992. Estimation of genetic variation in an improved population of maize (*Zea mays* L.). *Madras Agric. J.* 79(12):714-719.
- Rezaei, A. H., B. Yazdisamadi, A. Zali, A. M. Rezaei, A. Tallei, H. Zeinali. 2005. An estimate of heterosis and combining ability in corn using diallel crosses of inbred lines. *Iranian J. Agric. Sci.* 36(2): 385-397.
- Robinson, H. F., R. E. Comstock and P. H. Harvey. 1951. Estimates of heritability and degree of dominance in corn. *Agron. J.* 41: 353-359.
- Rojas, B. A. and G. F. Sprague. 1952. A comparison of variance components in corn yield trials. III. General and specific combining ability and their interactions with locations and years. *Agron. J.* 44: 462-466.
- Roy, N. C., S. U. Ahmed, S. A. Hussain. And M. M. Hoque. 1998. Heterosis and combining ability in maize (*Zea mays* L.) Bangladesh *J. Pl. Breed. Genet.* 11 (1&2): 35-41.
- Ruckij, I. A. 1963. Efficiency of intervarietal hybridization using wide geographical crosses of maize. *Trans. Bot. Varaner Univ.* 2: 7-18.
- Sachan, K. S. and J. R. Sharma. 1971. Multivariate analysis of divergence in tomato. *Indian J. Genet.* 31:86-93.
- Sadek S. E., M. A. Ahmed and H. M. Abd El- Gahancy. 2006. Correlation and path coefficient analysis in five patterns lines and their six white maize (*zea mays* L.) single crosses development and grown in Egypt. *J. Appl. Sci. Res.* 2(3):159-167.
- Saha, B. C. and B. K. Mukherjee. 1985. Analysis of heterosis for number of grains in maize (*Zea mays* L.). *Indian J. Pl. Breed.* 45: 240-246.
- Saha, B. C. and B. K. Mukherjee. 1993. Grain yield of maize in relation to grain farming potential and other traits. *J. Res. Birsa Agric. Univ.* 5:27-31.

- Salami, A. E., S. A. O. Adegoke and O. A. Adegbite. 2007. Genetic variability among maize cultivars grown in Ekiti-State, Nigeria. *Middle-East J. Sci. Res.* 2(1): 09-13.
- Sallahuddin, A. 2008. Studies on the genetic diversity of maize (Set 1). Annual Research Report. 5-8.
- Samad, A. 1991. Genetic study and genotype environment interaction of some agronomical characters in rape seed (*Brassica campestris* L.). Ph. D. Thesis, Rajshahi University, Bangladesh.
- Samsuddin, A. K. 1985. Genetic diversity in relation to heterosis and combining analysis in spring wheat. *Theor. Appt. Genet.* 70: 306-308.
- San-Vicente, F. M., A. Bejarano, C. Martin and J. Crossa. 1998. Analysis of diallel crosses among improved tropical white endosperm maize population. *Maydica* 43(2): 147-153.
- Satyanarayana, E and R. Saikumar. 1996. Genetic variability of yield and maturity components in maize hybrids. *Current Res. Univ. Agric. Sci. Bangalore.* 25(1): 10-11.
- Satyanarayana, E. and R. Saikumar. 1995. Genetic variability and *per se* performance of non-conventional hybrids in maize. *Mysore J. Agric.* 29 (3): 213-218.
- Saxena, V. K., K. Singh and N. S. Malhi. 1996. Intra-population variability in maize cultivar. *Crop Improvement.* 13: 144-148.
- Shabir, G. and M. Saleem. 2002. Gene action for protein content of maize grain in diallel cross. *Pak. J. Seed Tech.* 1(2): 53-56.
- Shahi, J. P. and I. S. Singh. 1985. Estimation of genetic variability for grain yield and its components in random mating population in maize. *Crop Improv.* 12: 126 – 129.
- Shakil, Q. 1992. Genetic analysis for quantitative characters in diallel crosses of maize inbred lines. M.Sc. Thesis, Department of Plant Breeding and Genetics, University of Agriculture, Faisalabad, Pakistan.

- Shamim, Z., A. Bakhsh, A. Hussain, K. S. Ahmed, M. K. Mehmood and I. H. Khalil. 2010. Genetic variability among maize genotypes under agro climatic conditions of Kotli (Azad Kashmir). *World Applied Sci. J.* 8(11): 1356-1365.
- Sharma, S. R., A. S. Khera, B. S. Dhillon and V. V. Malhotra. 1982. Evaluation of S₁ lines of maize crossed in a diallic system. *Crop Improv.* 9: 42-47.
- Shelake, D. V., S. G. Bhave, V. W. Bendale, R. R. Madav and U. B. Pethe. 2005. Genetic factors influencing grain yield in maize. *J. Ecobiol.* 17(6): 521-528.
- Shiv. K., S. S. Malik., A. S. Jeena and S. K. Malik. 2008. Interrelationships among the yield attributes and intergeneration correlation as a mean of testing effectiveness of early generation testing in wheat (*Triticum aestivum* L.). *Prog. Res.* 3(1): 25-30.
- Shull, G. H. 1908. The composition of a field of maize. *American. Breed. Assoc. Rep.* 4: 296-301.
- Shull, G. H. 1909. A pure line method of corn breeding. *Amer. Breeders Assoc. Rep.* 5: 51-59.
- Singh, A. K., J. P. Shahi, J. K. Singh and R. N. Singh. 1998. Heritability and genetic advance for maturity and yield attributes in maize. *J. Appl. Biology.* 8 (1): 42-45.
- Singh, D. N and I. S. Singh. 1998. Line \times tester analysis in maize (*Zea mays* L.). *J. Res. Birsa Agric. Univ.* 10 (2): 177-182.
- Singh, H., A. S. Khehra and B. S. Dhillon. 1991. Genetic architecture of two heterotic populations of maize. *Maydica* 30:31-36.
- Singh, J. M. and B. Dashi. 2000. Analysis of genetic variability and character association in maize (*Zea mays* L.). *Environ. & Ecol.* 18(2): 503-505.
- Singh, P. and S. S. Narayanan. 1993. *Biometrical Techniques in Plant Breeding.* Kalyani Publishers, Ludhiana, New Delhi, India.

- Singh, P. K., A. K. Singh, J. P. Shahi and R. Rahman. 2012. Combining ability and heterosis in quality protein maize. *The Biocan* 7(2):337-341.
- Singh, P. K., M. K. Prasad and L. B. Chaudary. 1999. Association analysis in winter maize. *J. Appl. Biol.* 9(2): 133-136.
- Singh, P. K., P. B. Jha and P. Kumar. 2003. Path coefficient for green fodder yield and grain yield in maize (*Zea mays* L.). *J. Appl. Biol.* 13(1&2): 29-32.
- Singh, P., D. Sain, V. K. Dwivedi, Y. Kumar and O. Sangwan. 2005. Genetic divergence studies in maize (*Zea mays* L.). *Ann. Agric. Biol. Res.* 10(1): 43-46.
- Singh, R. K and B. D. Chaudhary. 1985. *Biometrical Methods in Quantitative Genetic Analysis*. Kalyani Publishers, New Delhi.
- Singh, S. B. 1979. Genetic analysis for grain yield and other quantitative traits in inbred lines of maize (*Zea mays* L.). Ph. D. Thesis, Banaras Hindu Univ. Varansi, India.
- Singh, S. P. and H. K. Nigam. 1977. Path coefficient analysis for yield components in maize. *Allahabad Farmer.* 48:163-165.
- Singha, N. and H. S. Prodhan. 2000. Character association in green maize. *Environ. & Ecol.* 18(4): 962-965.
- Smith, H. F. 1936. A discriminant function for plant selection. *Annual Eugenics.* 7: 240-250.
- Sofi, P. A. and A. G. Rather. 2007. Studies on genetic variability, correlation and path analysis in maize (*Zea mays* L.). *Maize Genetics Co-operation News Lett.* 81:26-27.
- Soliman, F. H., G. A. Morshed, M. M. A. Ragheb and M. Kh. Osaman. 1999. Correlations and path coefficient analysis in four yellow maize hybrids grown under different levels of plant population densities and nitrogen fertilization. *Bull. Fac. Agric. Cairo Univ.* 50:639-658.

- Spaner, D., R. A. J. Brathwaite and D. E. Mather. 1996. Diallel study of open-pollinated maize varieties in Trinidad. *Euphytica* 90 (1): 65- 72.
- Sprague, G. F and L. A. Tatum. 1942. General vs. specific combining ability in single crosses of corn. *J. American. Soc. Agron.* 34:923-932.
- Sreckov, Z., J. Bocanski, A. Nastasic, I. Dalovic and M. Vukosavljev. 2010. Correlation and path coefficient analysis of morphological traits of maize (*Zea mays* L.). *Res. J. Agril. Sci.* 42(2):292-296.
- Srivastava, S. K. and U. P. Singh. 2004. Genetic variability, character association and path analysis of yield and its component traits in forage maize (*Zea mays* L.). *Range Manag. Agroforestry.* 25(2):149-153.
- Sumathi, P., A. Nirmalakumari and K. Mohanraj. 2005. Genetic variability and traits interrelationship studies in industrially utilized oil rich CIMMYT lines of maize (*Zea mays* L.). *Madras Agric. J.* 92(10-12): 612 – 617.
- Suneetha, Y., J. R. Patel and T. Srinivas. 2000. Studies on combining ability for forage characters in maize (*Zea mays* L.). *Crop Res. Hisar.* 19(2): 266-270.
- Swamy, R.T., A. Ramamurthy, S. J. Patil, R. S. Aradhya and M. Mahadevappa. 1970. Genetic variability and heterosis in maize. *Madras Agril. J.* 58:620-623.
- Swarnalatha. D. I. and S. Mohammad. 2001. Character association and path coefficient analysis of grain yield and components in double crosses of maize. *Crop Res.* 21: 355-359.
- Szatmari, M. 1996. Comparison of the correlation between the quantitative traits of maize (*Zea mays* L.) and their general combining abilities in a changing environment. *Novenytermeles.* 45(4): 345-3 52.
- Tallei, A and H. N. K. Kochaksaraei. 1999. Study of combining ability and cytoplasmic effects in maize diallel crosses. *Iranian J. Agric. Sci.* 30 (4): 761-769.

- Tan Heping, Wang Guiyue, Hu-Xiamnu and Xu-Qiaoxian. 2006. Multiple regression and path analysis of effective factors affecting maize yield. *Acta Agriculturae Zhejiangensis*. 18(4): 238-240.
- Tiwari, V. K and S. S. Verma. 1999. Genetic variability studies for baby corn in maize (*Zea mays*L.). *Agric. Sci. Dig. Karnal*. 19(1): 67-71.
- Tulu, L and B. K Ramachandrappa. 1998. Combining ability of some traits in a seven parent diallel cross of selected maize (*Zea mays* L.) populations. *Crop Res. Hisar*. 15(2-3): 232-237.
- Tyagi, A. P., G. P. Pokhariyal and O. M. Odongo. 1988. Correlation and path coefficient analysis for yield components and maturity traits in maize (*Zea mays* L.). *Maydica* 33: 109-119.
- Uddin, M. S., F. Khatun, S. Ahmed, M. R. Ali and S. A. Begum. 2006. Heterosis and combining ability in corn (*Zea mays* L.). *Bangladesh J. Bot.* 35 (2): 109-116.
- Uddin, M. S., M. Amiruzzaman, S. A. Begum, M. A. Hakim and M R. Ali. 2008. Combining ability and heterosis in maize (*Zea mays* L.). *Bangladesh J. Genet. Pl. Breed.* 21(1): 21-28.
- Umakanth, A. V., E. Satyanarayana and M. V. N. Kumar. 2000. Correlation and heritability studies in Ashwini maize composite. *Ann. Agric. Res.* 21: 328-330.
- Utkhede, R. S. and P. T. Shukla. 1976. Path co-efficient analysis and its application in maize improvement. *Egyptian J. Genet. Cytol.* 5: 164-169.
- Vacaro, E., J. Fernandes, B. Neto, D. G. Pegoraro, C. N. Nuss and L. H. Caceicao. 2002. Combining ability of twelve maize populations. *Pesq. Agropec. Brac, Brasilia*. 37:67-72.
- Vaezi, S., C. Abd-Mishani, B. Yazdi-Samadi and M. R. Ghannadha. 2000. Correlation and path analysis of grain yield and its components in maize. *Iranian J. Agric. Sci.* 31(1): 71-83.

- Vasal, S. K. 2000. Manifestation and Genotype x environment interaction of heterosis. *In*: Training course handouts and material on hybrid technology and seed production in maize. February 22–26, 2000. BRAC Centre, Gazipur, Bangladesh.
- Vasal, S. K., G. Srinivasan, F. C. Gongalez, D. L. Beck and J. Crossa. 1993b. Heterosis and combining ability among CIMMYT's quality protein maize germplasm. II Sub tropical. *Crop Sci.* 33:51-57. .
- Vasal, S. K., G. Srinivasan, F. C. Gongalez, G. C. Hab, S. Pandey, D. L. Beck and J. Crossa. 1992b. Heterosis and combining ability among CIMMYT's tropical x subtropical germplasm: *Crop Sci.* 32:1483–1489.
- Vasal, S. K., G. Srinivasan, J. Crossa and D. L. Beck. 1992a. Heterosis and combining ability among CIMMYT's subtropical and temperate early maturity maize germplasm. *Crop Sci.* 32: 884-890.
- Vasal, S. K., G. Srinivasan, S. Pandey, F. C. Gongalez, J. Crossa and D. L. Beck. 1993. Heterosis and combining ability among CIMMYT's quality protein maize germplasm: 1. Lowland tropical. *Crop Sci.* 33:46–51.
- Vasal, S. K., G. Srinivasan, S. Pandey, F. C. Gongalez, J. Crossa and D. L. Beck. 1993a. Heterosis and combining ability among CIMMYT's quality protein maize germplasm. I. Lowland tropical. *Crop Sci.* 33:46-51
- Vasic, N., M. Ivanovic, L. Peternelli, J. D. Ockovic, M. Stojakovic and J. Bocanski. 2001. Genetic relationships between grain yield and yield components in a synthetic population and their implications in selection. *Acta Agronomica Hungarica.* 49(4): 337-342.
- Venugopal, M., N. A. Ansari and T. Rajanikanth. 2003. Correlation and path analysis in maize (*Zea mays* L.). *Crop Res. Hisar.* 25(3): 525-529.
- Verhalen, L.M. and J.C. Murray. 1967. A diallel analysis of several fiber property traits in upland cotton. *Crop Sci.* 7: 501-505.

- Viola, G., M. Ganesh, S. S. Reddy and C.V.S. Kumar. 2003. Studies on correlation and path coefficient analysis of elite baby corn (*Zea mays* L.) lines. *Prog. Agric.* 3(1/2): 22-24.
- Wali, M. C., P. M. Salimath, M. Prashanth and S. I. Harlapur. 2006. Studies on character association as influenced by yield, starch and oil in maize (*Zea mays* L.). *Karnataka J. Agric. Sci.* 19(4): 932-935.
- Wang Dachun. 2006. Hereditary correlation and path analysis of main traits in maize at different yield levels. *J. Maize Sci.* 14(2): 40-41.
- Wannows, A. A., H. K. Azam and S. A. A. Ahmed. 2010. Genetic variances, heritability, correlation and path coefficient analysis in yellow maize crosses (*Zea mays* L.). *Agric. Biol. J. N. American.* 1(4):630-637.
- Warner, J. N. 1952. A method of estimating heritability. *Agron. J.* 44: 427-430.
- Weikai Yan and Manjit Kang. 2003. GGE Biplot analysis. 207-228, New York.
- Wellhausen, E. J. 1978. Recent development in maize breeding in the tropics. *In: Maize Breeding and Genetics.* Walden DB (Ed.). John Wiley and Sons. Inc., New York. pp. 59-84.
- White, P. J. and L.A. Johnson. 2003. *Corn: Chemistry and Technology.* 2nd Edn., American Association of Cereal Chemists, St. Paul, MN., USA., ISBN-13:9781891127335, Pages:892.
- Williams, T. R. and A. R. Hallaver. 2000. Genetic diversity among maize hybrids. *Maydica J.* 45: 163-171.
- Williams, W. 1959. Heterosis and the genetics of complex characters. *Nature* 184: 527-530.
- Wright, S. 1923. The theory of path-coefficients a reply to Niles criticism. *Genetics* 8: 239-255.
- Wright, S. 1935. The analysis of variance and the correlation between relatives with respect to deviation from an optimum. *J. Genet.* 30: 243-256.

- Xie-Zhen Jiang, Li-Ming, Li-Xin. Zhang-Shi and Zhang-Baoshi. 2007, Relativity between yields and agronomic traits of major maize inbred lines of north China. J. Shenyang Agric. Univ. 38(3): 265-268.
- Yagdi, K and E. Sozen. 2009. Heritability, variance components and correlations of yield and quality traits in durum wheat (*Triticum durum* Desf.). Pakistan. J. Biot. 41(2):753-759.
- Yan, W. and L. A. Hunt. 2002. Biplot analysis of diallel data. Crop Sci. 42: 21-30.
- Yasien, M. 2000. Genetic behavior and relative importance of some yield components in relation to grain yield in maize (*Zea mays* L.). Ann. Agric. Sci. Moshtohor. 38(2): 689-700.
- Yin ZhiTong, Xue Lin, Deng DeXiang, Bian YunLong, Chen GuoQing and Lu HuHua. 2004. Cluster analysis of plant traits in maize inbreds. Southwest China J. Agric. Sci. 17(5): 563-566.
- Yuai, L., H. Jianhua, G. Zhijun and Z. Wei. 2006. Principal component analysis and cluster analysis of introduced maize varieties. J. Maize Sci. 14(2):16-18.
- Zelleke, H. 2000. Combining ability for grain yield and other agronomic characters in inbred lines of maize (*Zea mays* L.). Indian J. Genet. 60(1): 63-70.
- Zhao, R. G. 1999. Combining ability analysis of green ear yield of sweet corn. Jilin Agric. Univ. 21(1): 12-15.